

MEGA POWER

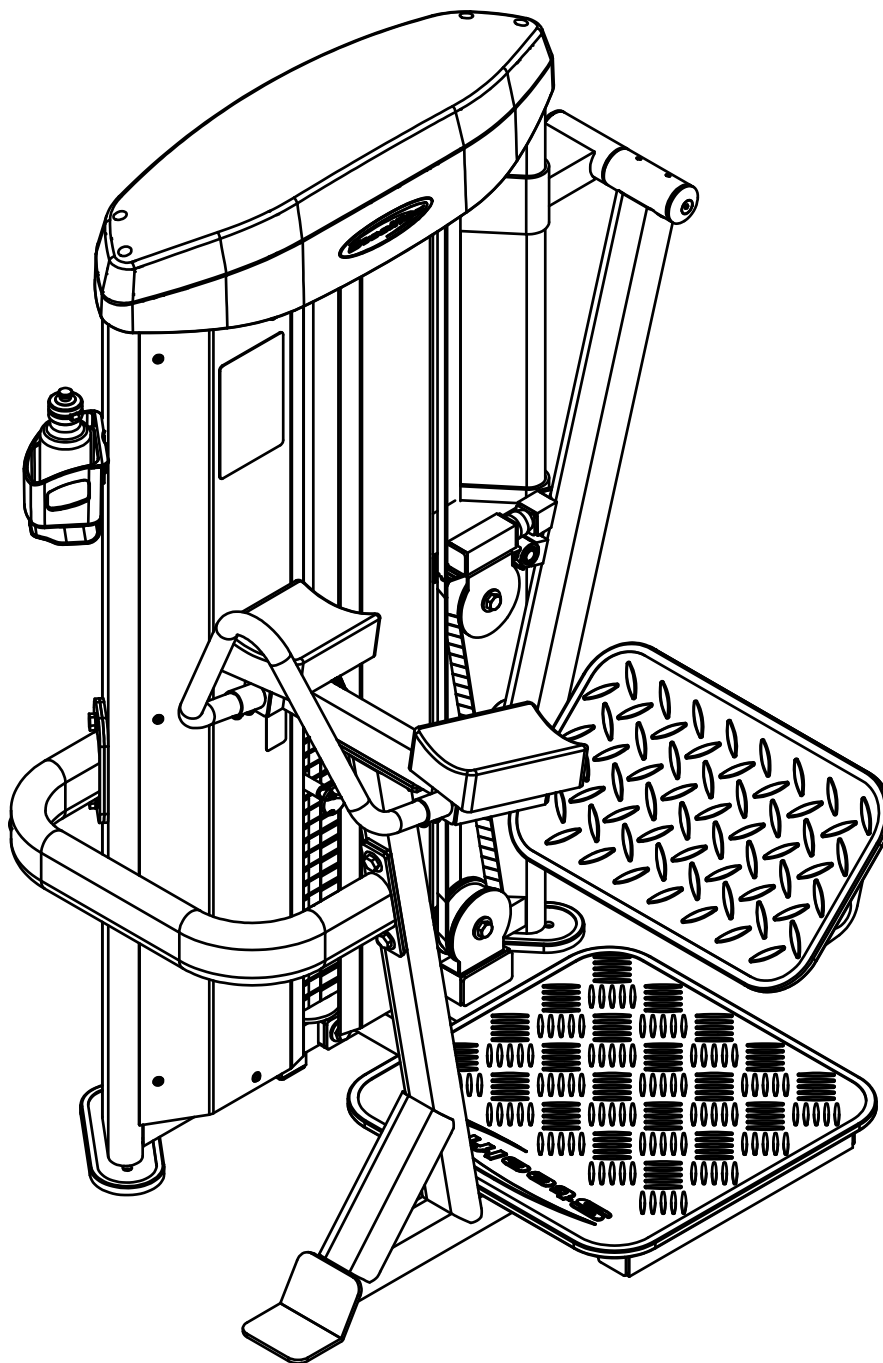

Steelflex

JOONG CHENN INDUSTRY CO., LTD.

Sales Office:

3F28, No.5, Shin-Yi Rd., Sec. 5, Taipei, Taiwan 110 R.O.C.

Tel: 886-2-27209980

Fax: 886-2-27229750

www.steelflexfitness.com

MHE-1900.2 OWNER'S MANUAL

MHE1900 ASSEMBLY INSTRUCTIONS

HARDWARE ILLUSTRATION

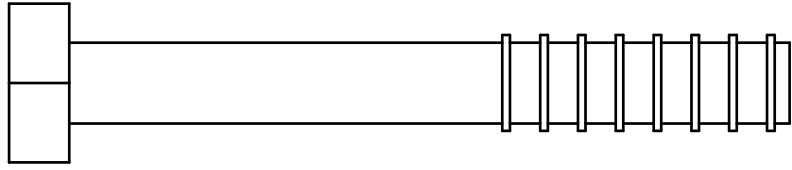
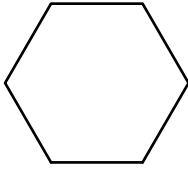

(A1)HEX BOLT 1/2"x3-3/4"L PARTIAL QTY.4

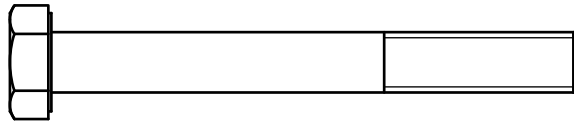
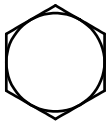

(A2)HEX BOLT M8X70L PARTIAL THREAD QTY.4

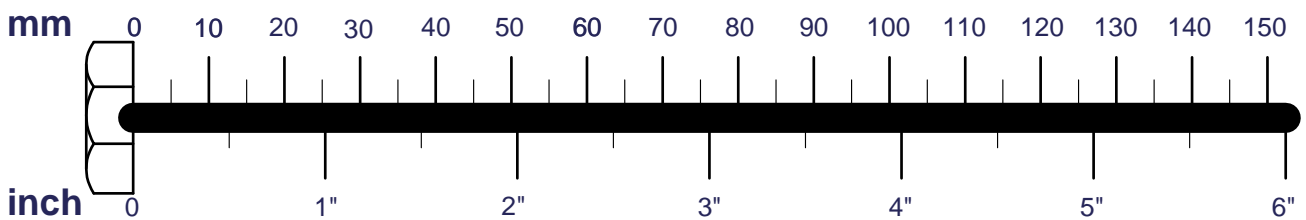

MHE1900 ASSEMBLY INSTRUCTIONS

HARDWARE ILLUSTRATION

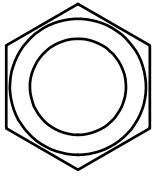

(B1) NYLON LOCK NUT 1/2" QTY.4

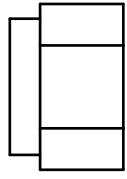

(C1) 1/2" (I.D.) FLAT WASHER Ø34 QTY.8

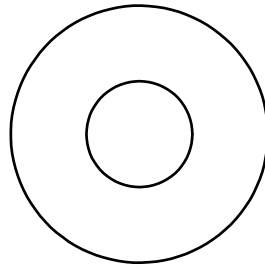

(C2) M8 (I.D.) FLAT WASHER Ø18 QTY.4

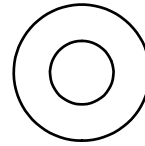

(C3) SPRING WASHER M8 QTY.4

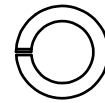

(C4) E- RING Ø24 QTY.1

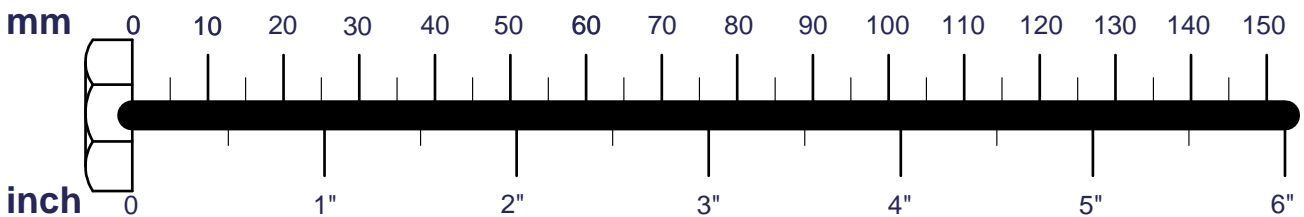

MHE1900 ASSEMBLY INSTRUCTIONS

FRAME HARDWARE ILLUSTRATION

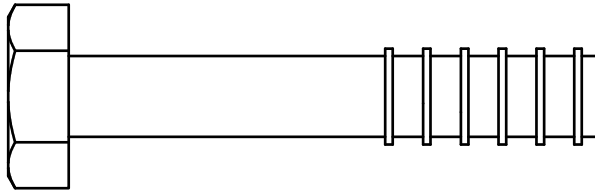
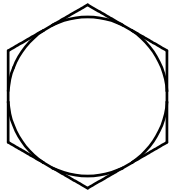

(AA1)HEX BOLT 1/2"x2-3/4"L PARTIAL QTY.4

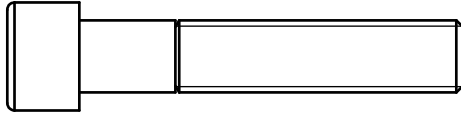
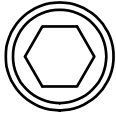

(AA2)ROUND INNER HEAD 3/8"x2"L PARTIAL QTY.1

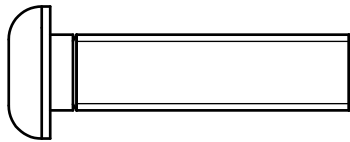
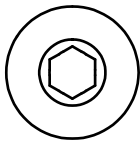

(AA3)ROUND INNER HEX SCREW M10x40L PARTIAL THREAD QTY.1

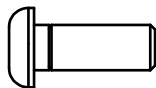

(AA4)ROUND INNER HEX SCREW M6x16L PARTIAL THREAD QTY.16

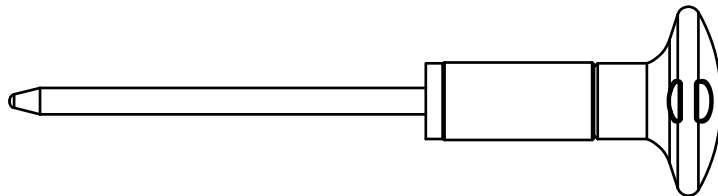

(AA5)10、15、20LB PIN(8250-162) QTY.1

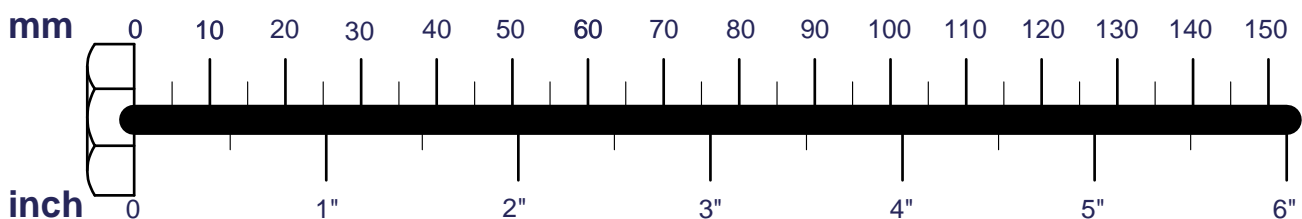

MHE1900 ASSEMBLY INSTRUCTIONS

FRAME HARDWARE ILLUSTRATION

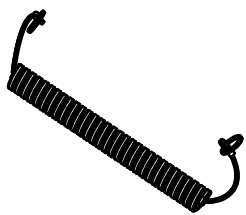

(AA6)ELASTIC BELT(F920003) QTY.1

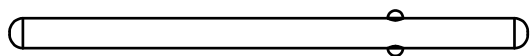

(AA7)Ø5/16" FIXED PIN (8250-166) QTY.1



(AA8)ROUND HEAD PHILLIPS M4X12L PARTIAL THREAD QTY.2

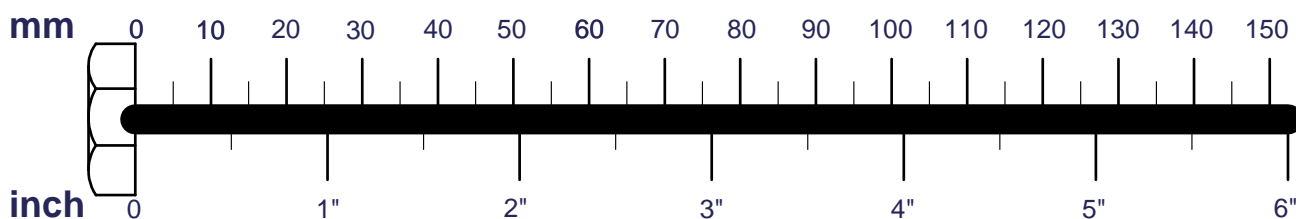

MHE1900 ASSEMBLY INSTRUCTIONS

FRAME HARDWARE ILLUSTRATION

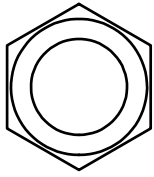

(BB1) NYLON LOCK NUT 1/2" QTY.4

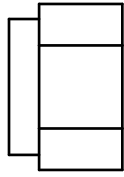

(CC3) M10 (I.D.) FLAT WASHER Ø19 QTY.2

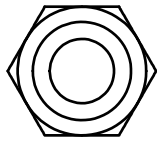
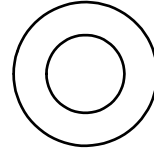

(BB2) NYLON LOCK NUT M10 QTY.1

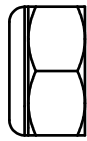

(CC4) M6 (I.D.) FLAT WASHER Ø19 QTY.16

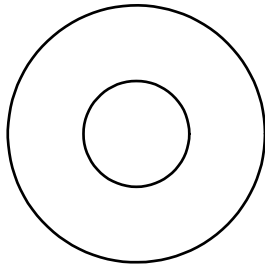
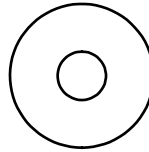

(CC1) 1/2" (I.D.) FLAT WASHER Ø34 QTY.5



(CC5) SPRING WASHER 3/8" QTY.1

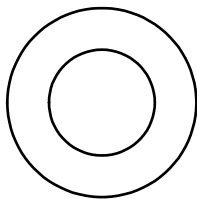
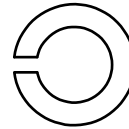

(CC2) 1/2" (I.D.) FLAT WASHER Ø25 QTY.3



mm

0 10 20 30 40 50 60 70 80 90 100 110 120 130 140 150

inch

0 1" 2" 3" 4" 5" 6"

MHE1900 ASSEMBLY INSTRUCTIONS

HARDWARE ILLUSTRATION

D1.Ø60 CAP COVER(8130-231)----- [2PCS]

D3.Ø38X26X1.5t CU WASHER(8520-008)----- [2PCS]

D4.108X15tX263L RUBBER PAD(9310-075)----- [1PCS]

D6.Ø115X50L PULLEY-NO MAGNET(9213-042B)----- [4PCS]

D7.3710mm BELT (FMHE1900A1)----- [1PCS]

D1.

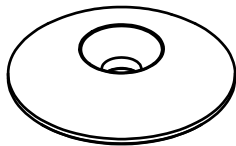

D3.



D4.

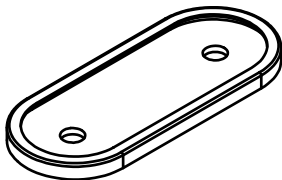

D6.

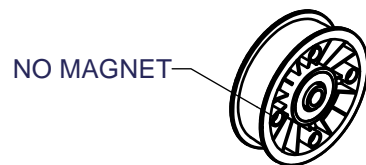

D7.

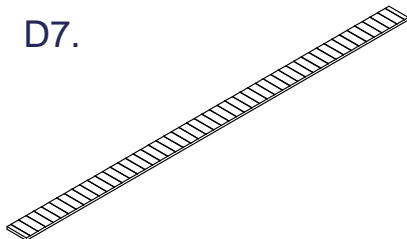

MHE1900 ASSEMBLY INSTRUCTIONS

FARME HARDWARE ILLUSTRATION

DD1.Ø3/4" SHAFT COLLAR(9211-147)-----	[2PCS]
DD2.Ø4" RUBBER DOUNT(9310-017)-----	[2PCS]
DD3.108X14.5tX263L RUBBER PAD(9310-075)-----	[2PCS]
DD4.BOTTLE BRACKET(8388-025)-----	[1PCS]
DD5.BOTTLE RACK(9260-320)-----	[1PCS]
DD6.BOTTLE(9260-123)-----	[1PCS]
DD7.TOP PLATE(8400-033)-----	[1PCS]
DD8.Ø3/4" SHAFT COLLAR(9211-167)-----	[2PCS]
DD9.WEIGHT SELECTOR BAR(8210-216C)-----	[1PCS]

DD1.

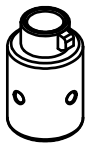

DD2.

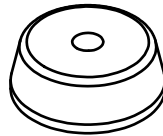

DD3.

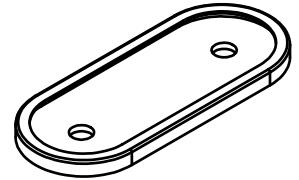

DD4.



DD5.

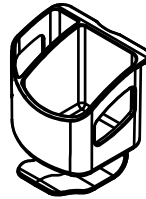

DD6.

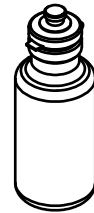

DD7.

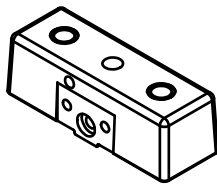

DD8.

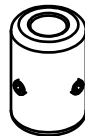

DD9.

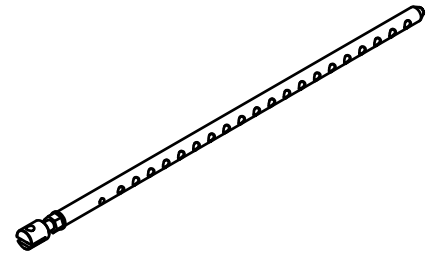

MHE1900 ASSEMBLY INSTRUCTIONS

PARTS ILLUSTRATION SHEET

A [1SET]

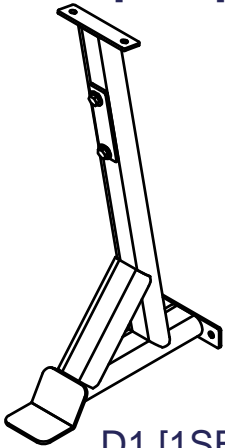

B [1SET]

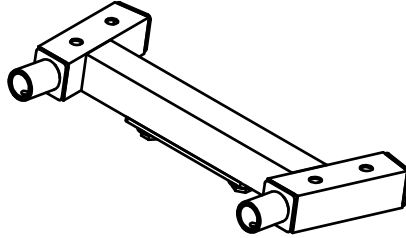

C [1SET]

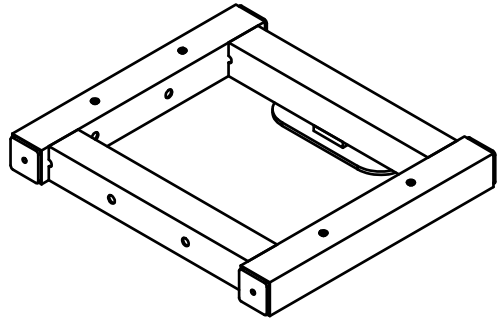

D1 [1SET]

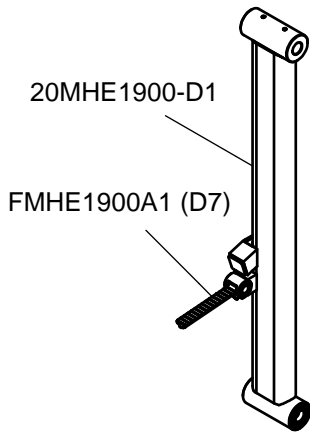

E [1SET]

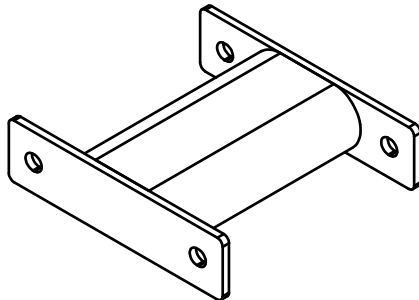

F [1SET]

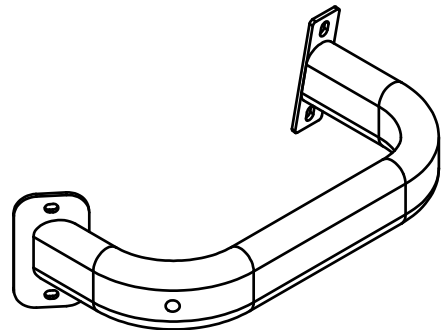

G [1SET]
280266

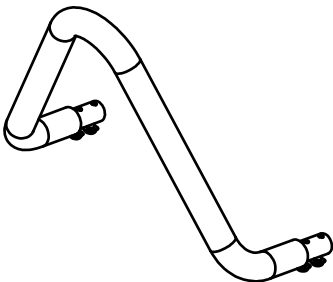

H [1SET]
8220-304
Ø25X264L

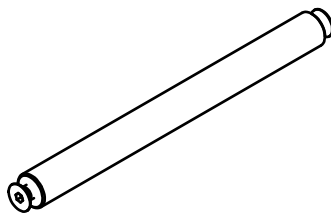

I [2PCS]
8312-077

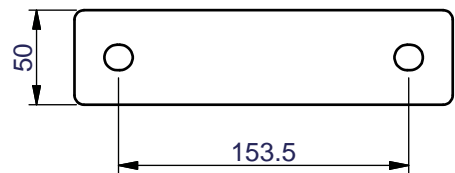

J [1PCS]
8313-265

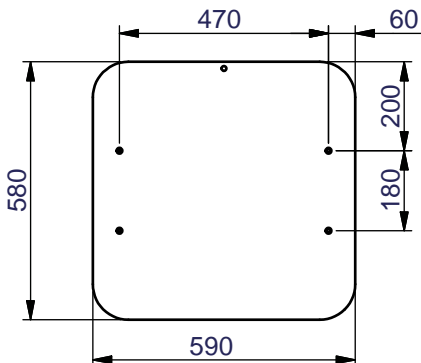

K [1PCS]
9310-095

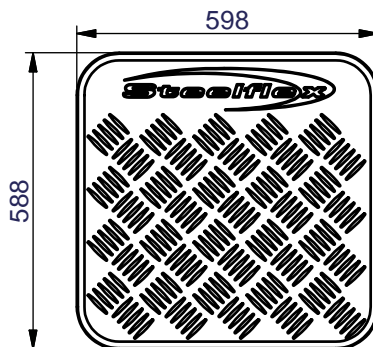

L [1SET]
9420-145

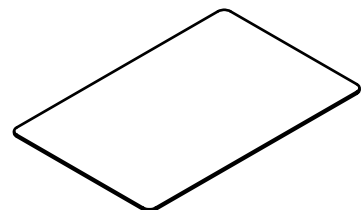

PARTS ILLUSTRATION SHEET

M [2SET]
9131-060

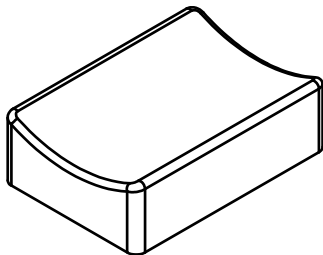

Q [1SET]
20MHE1900-H

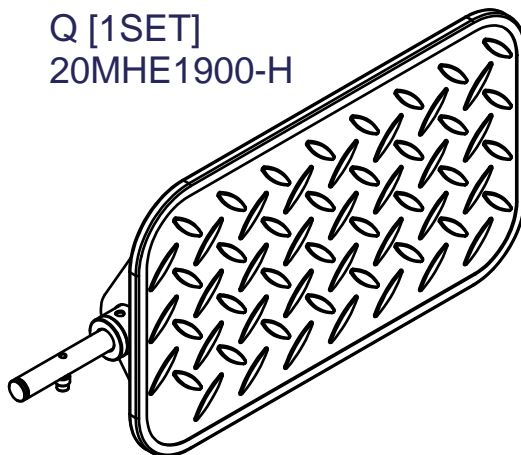

MHE1900 ASSEMBLY INSTRUCTIONS

FARME PARTS ILLUSTRATION SHEET

AA1 [1SET]
20MHE1900-G1

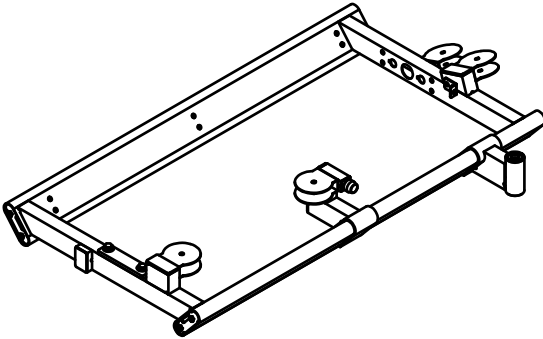

AC [1PCS]
9220-016

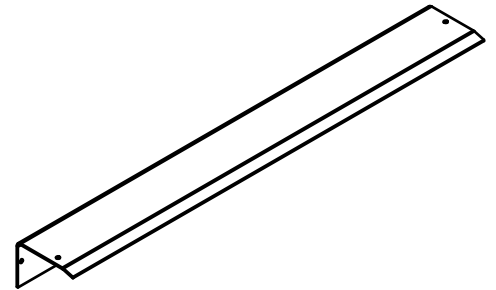

AD1 [1PCS]
9220-052

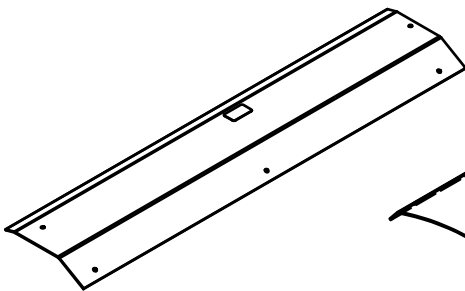

AE [1SET]
9220-023

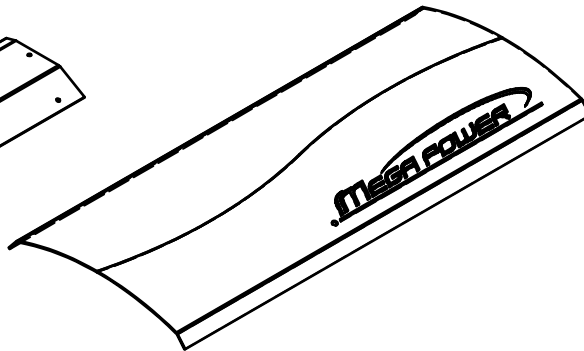

AF [1SET]
9211-148

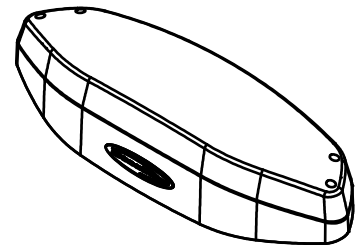

AG [4SET]
8331-057

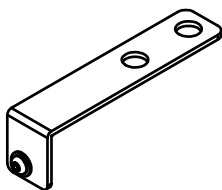

AH [1SET]
8313-169

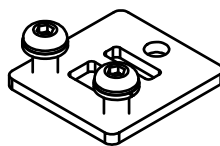

AJ [2PCS]
8280-042
Ø3/4"X1433L

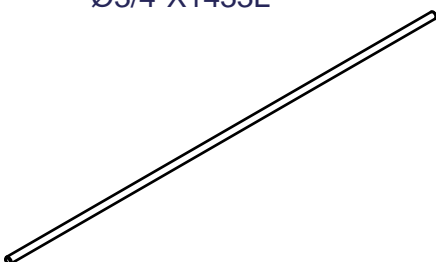

AK [1PCS]
8331-056

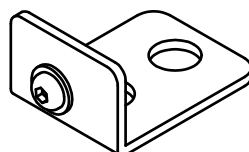

AL [3SET]
8331-058

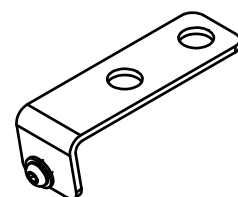

MHE1900 ASSEMBLY INSTRUCTIONS

FARME PARTS ILLUSTRATION SHEET

AM [2PCS]
8313-144

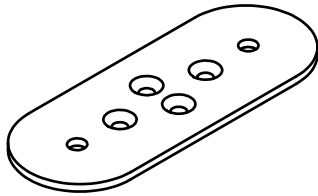

AP [1PCS]
8311-117

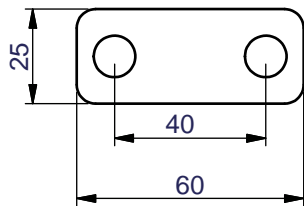

AQ [1PCS]
8311-194

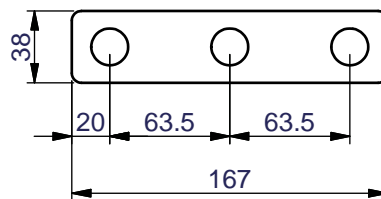

MHE1900 ASSEMBLY INSTRUCTIONS

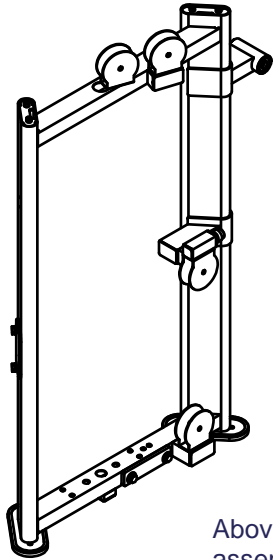

Above shows STEP 1
assembled and completed

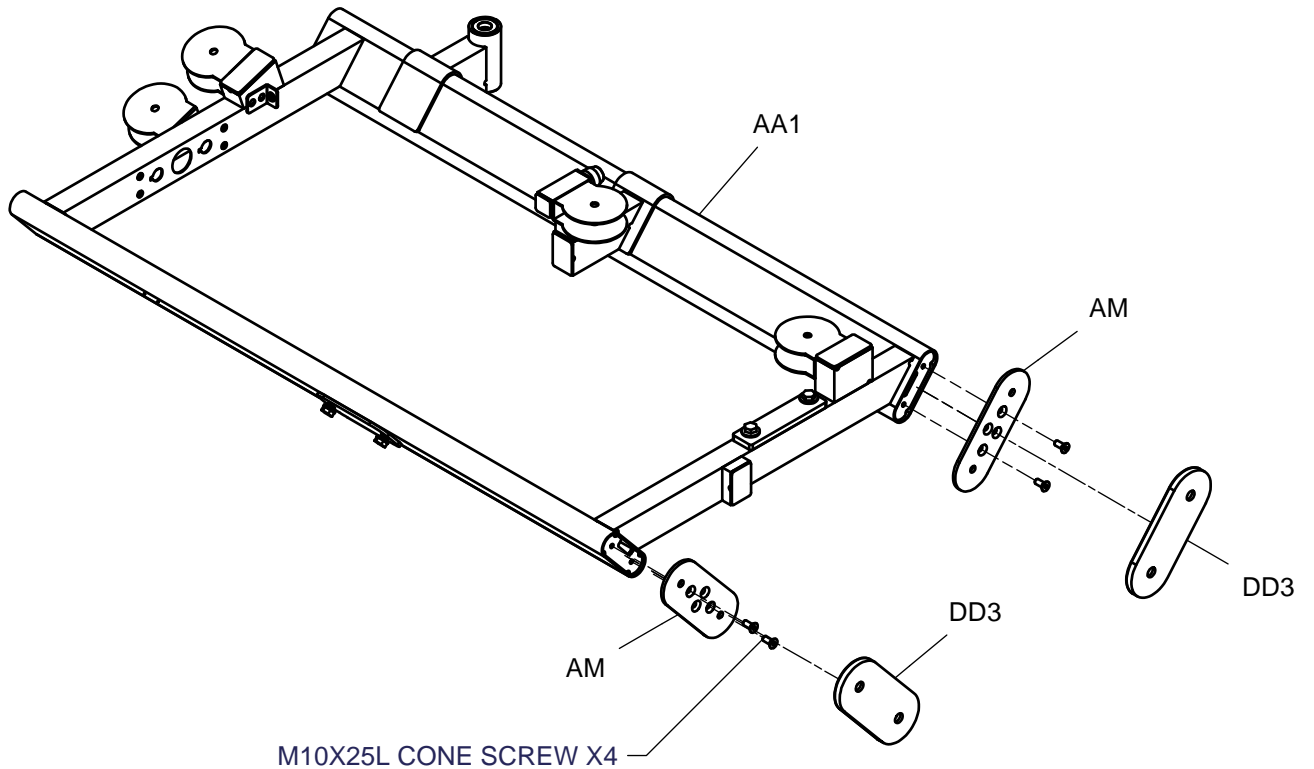

MHE1900 ASSEMBLY INSTRUCTIONS

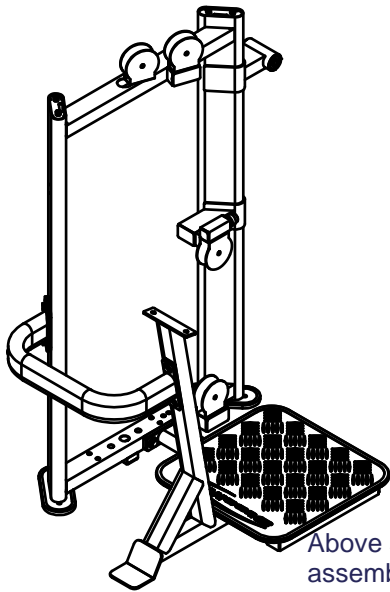

Above shows STEP 2 assembled and completed

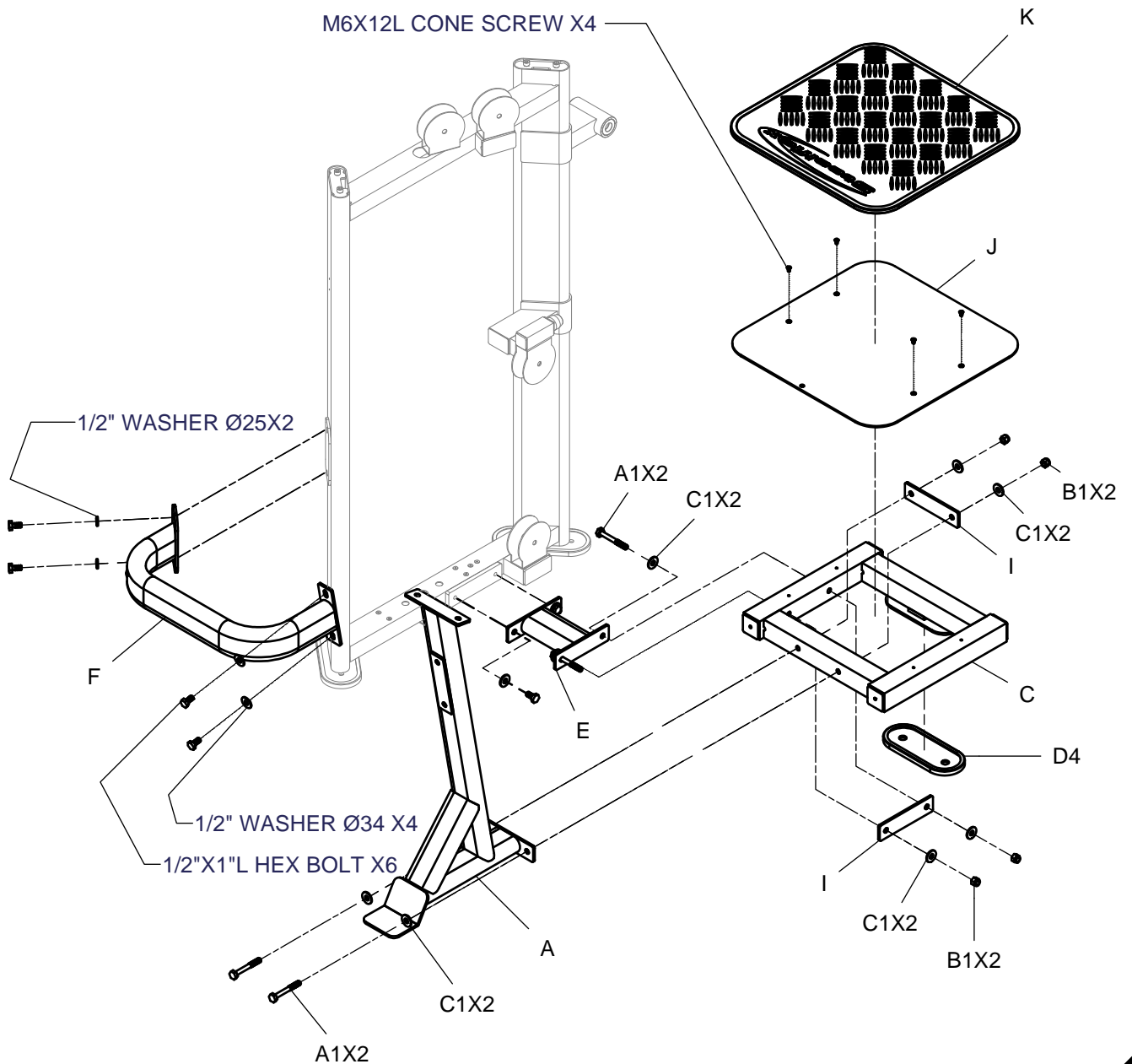

MHE1900 ASSEMBLY INSTRUCTIONS

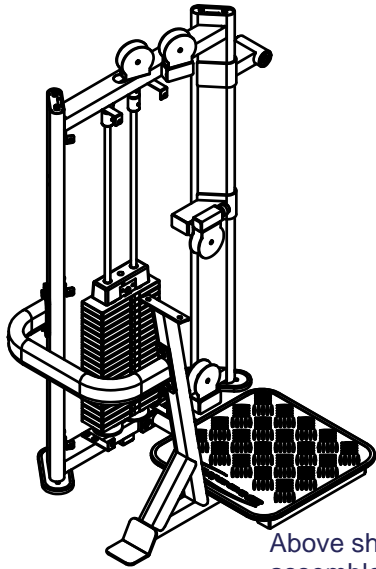

Above shows STEP 3 assembled and completed

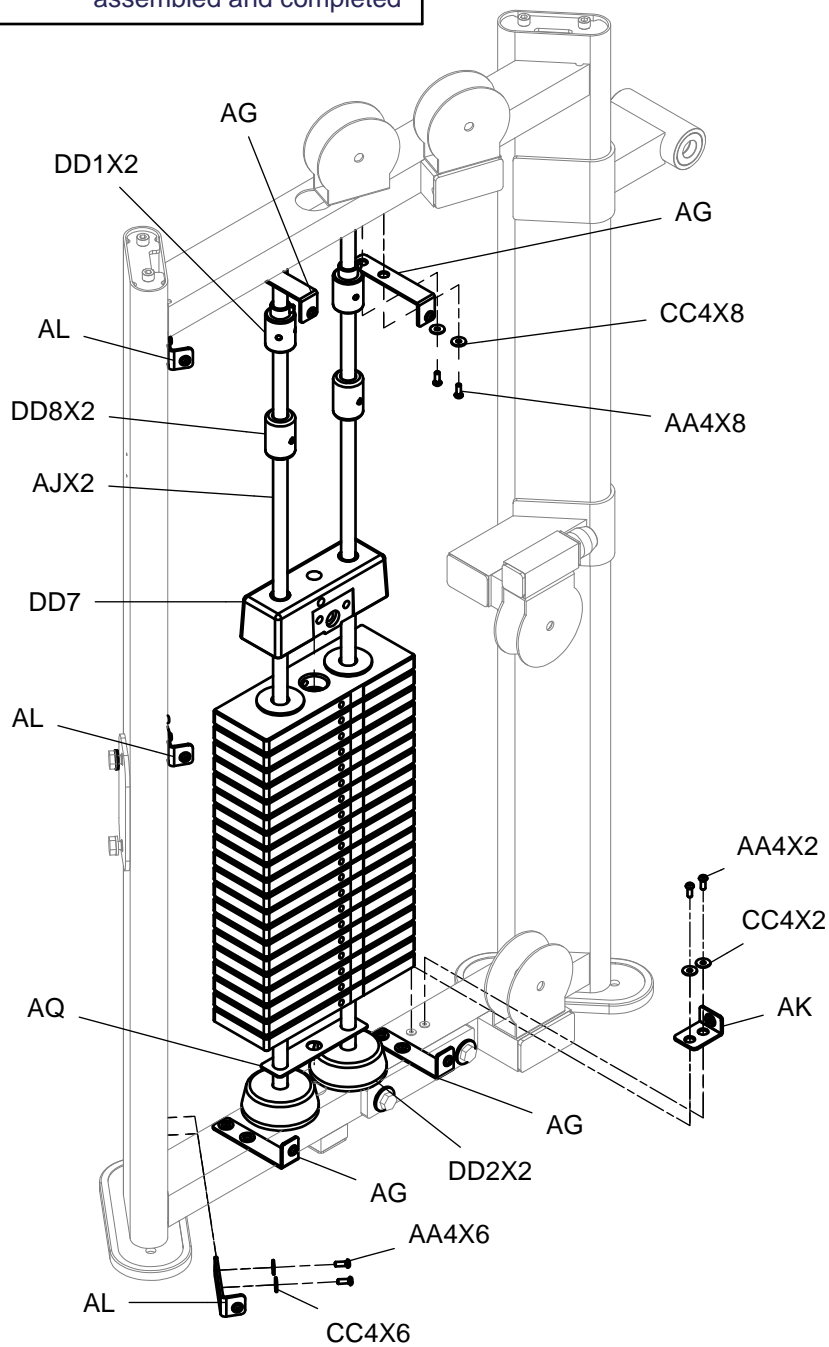

MHE1900 ASSEMBLY INSTRUCTIONS

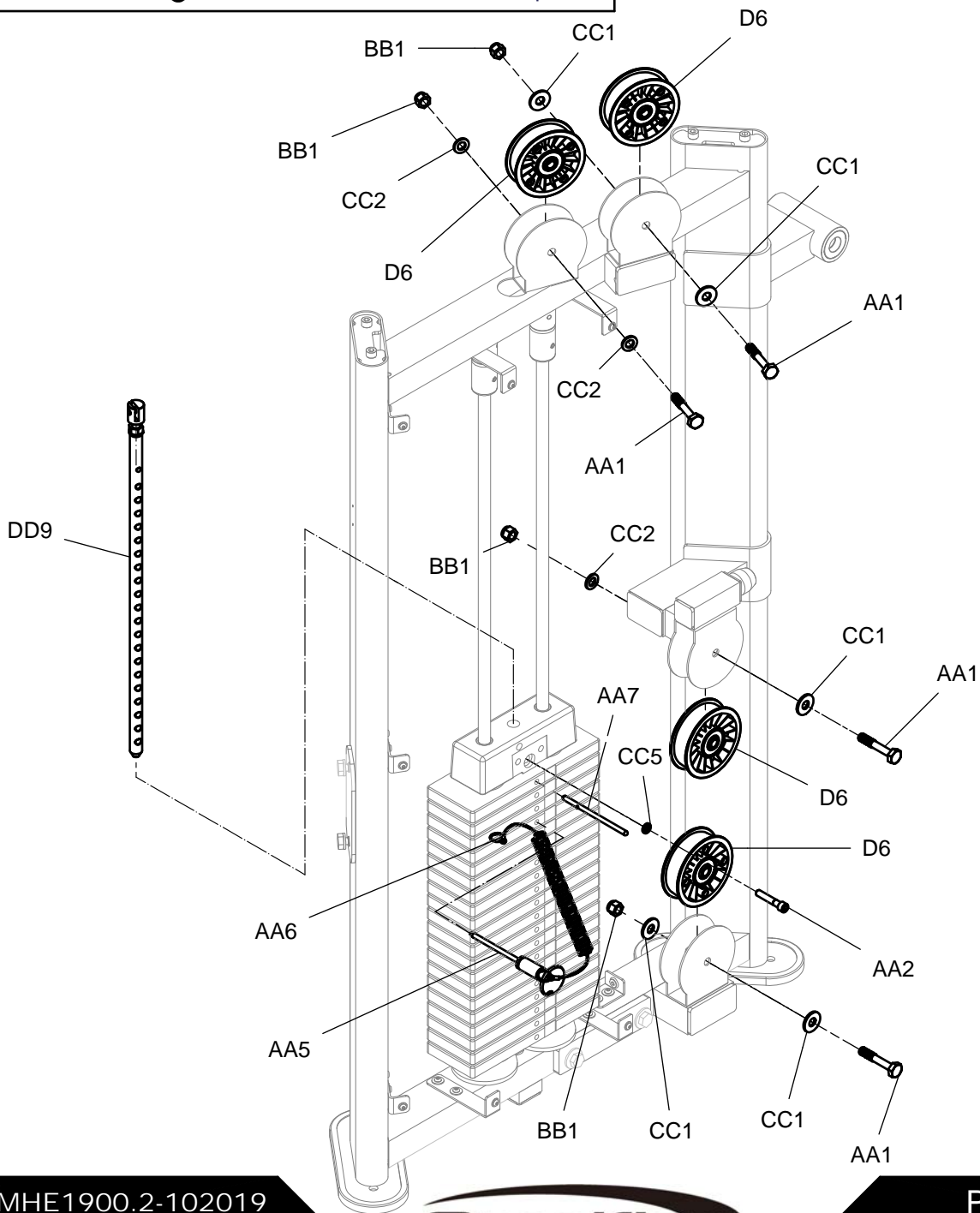
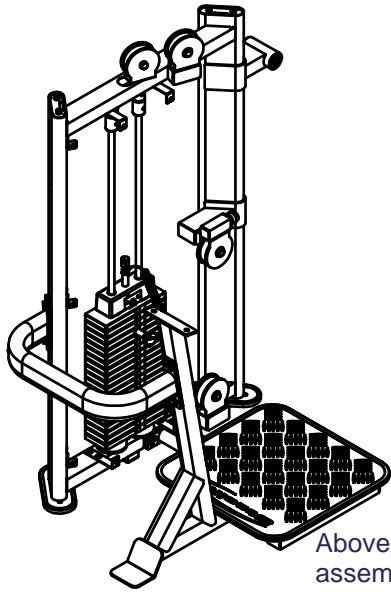

MHE1900 ASSEMBLY INSTRUCTIONS

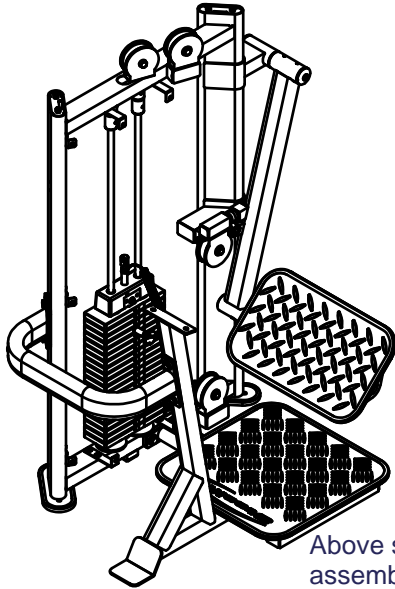

Above shows STEP 5 assembled and completed

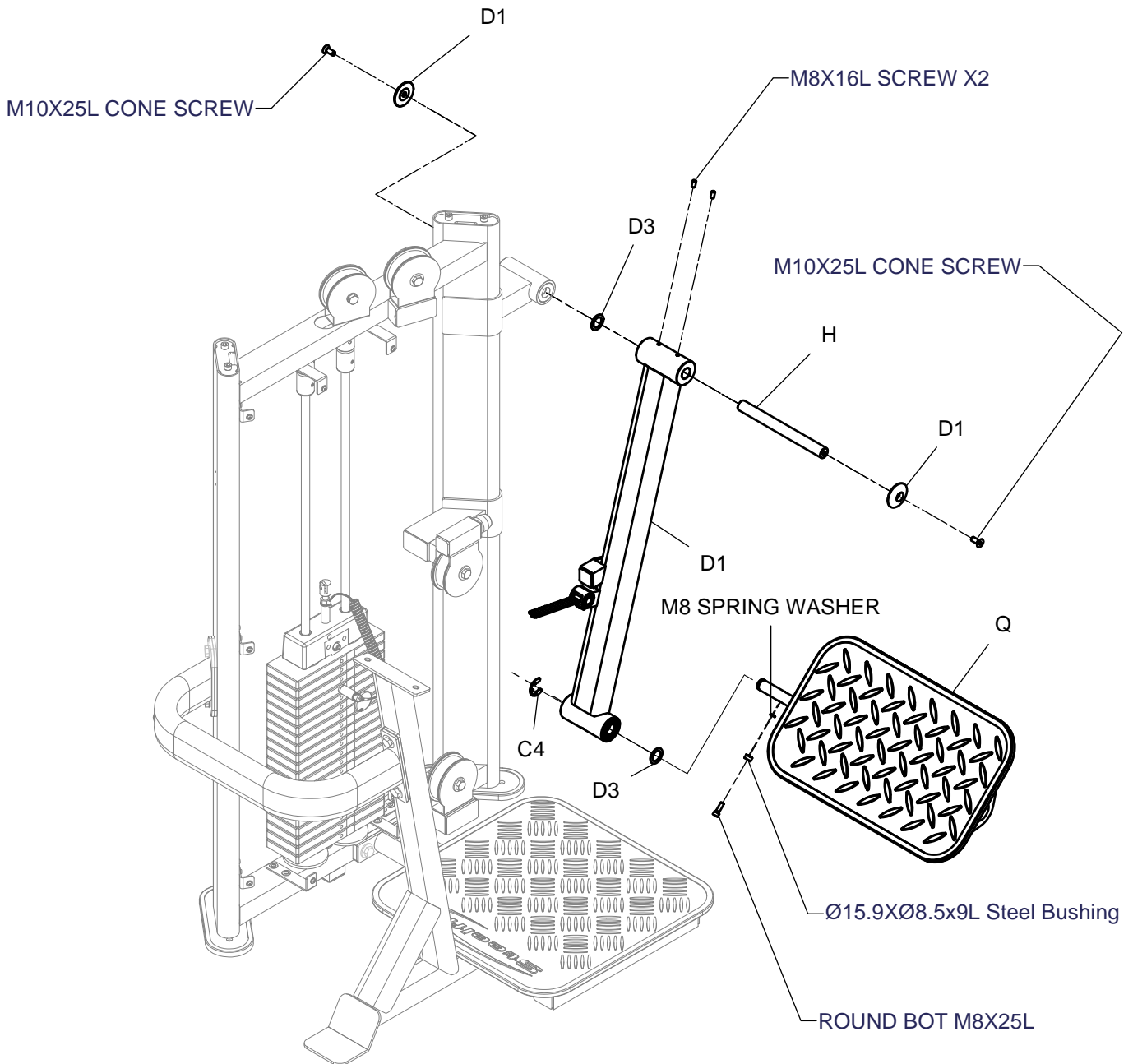

MHE1900 ASSEMBLY INSTRUCTIONS

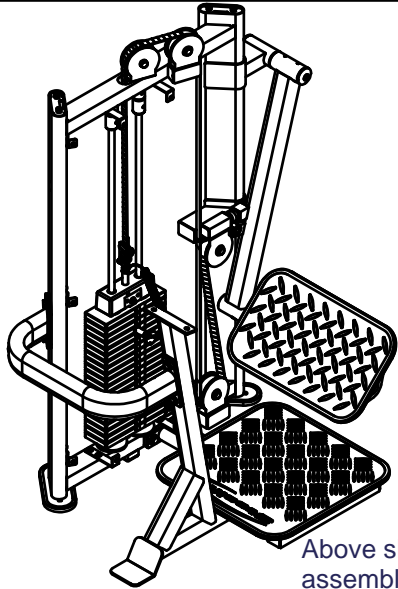

Above shows STEP 6 assembled and completed

The tread side should be outward

M10X25L ROUND BOLT X2
M10 SPRING WASHER X2

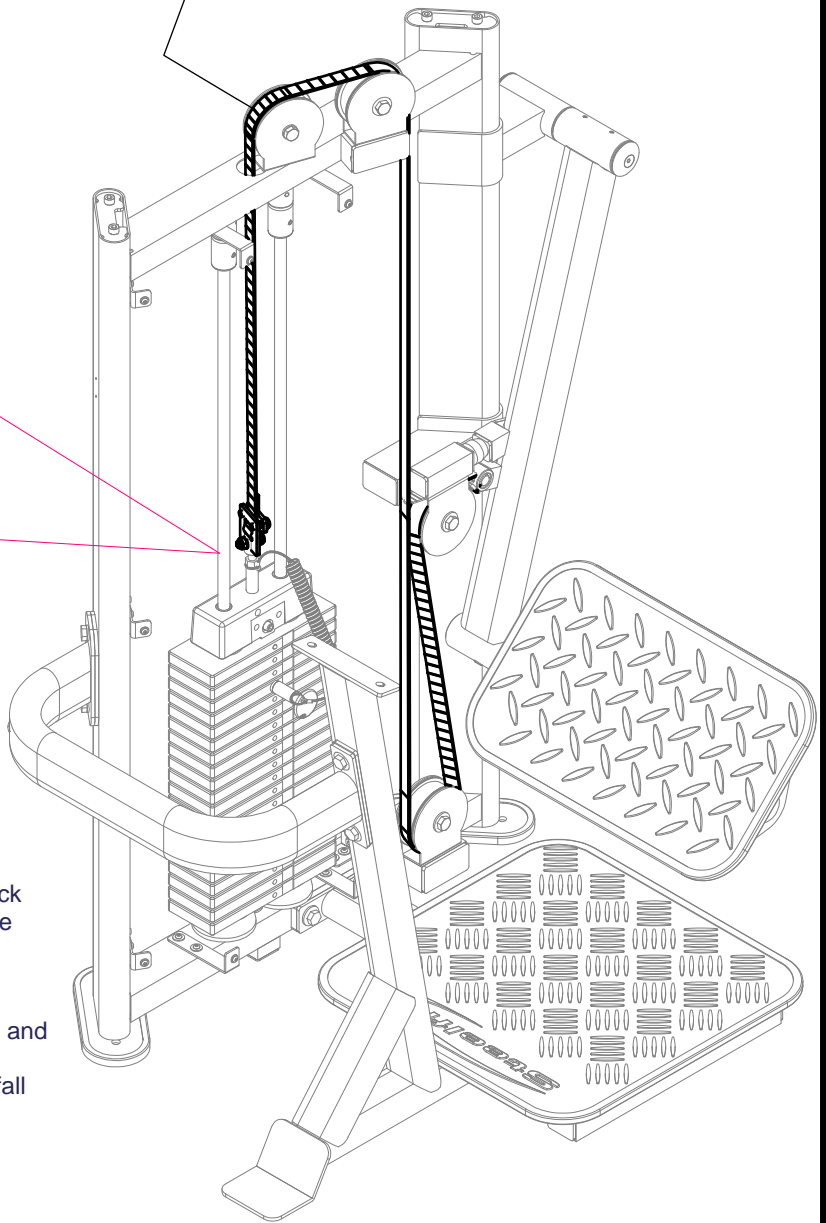
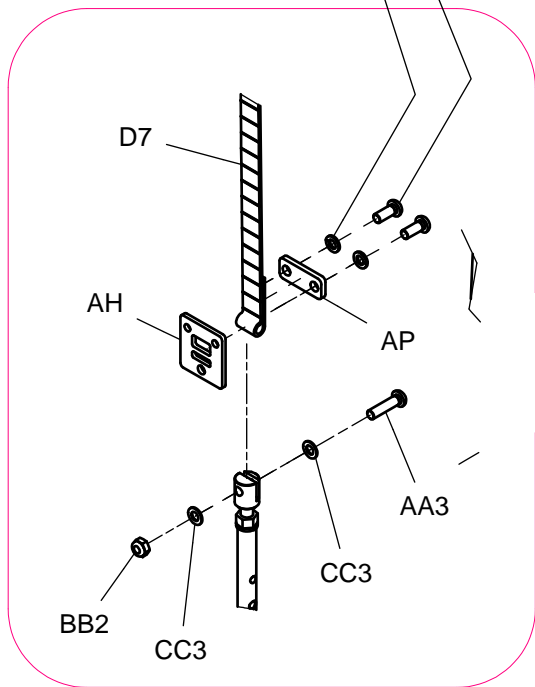

Adjust Belt Procedure:

1. Lift the selector rod a little and then insert the pin between first weight stack and top plate (Do not insert though the first hole of the rod), and there are 7 mm gap between top plate and first weight stack.
2. Adjust the belt to have proper tension and then tighten the belt clamps
3. Remove the pin and let the top plate fall on the first weight plate.

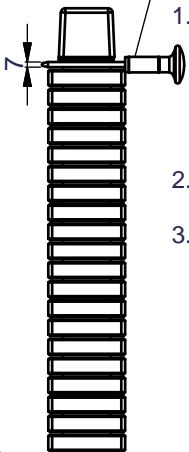

MHE1900 ASSEMBLY INSTRUCTIONS

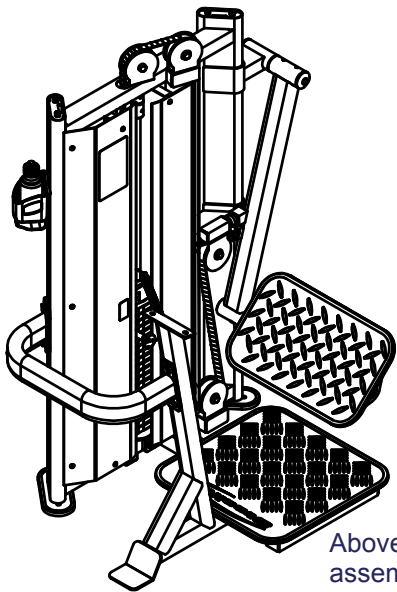

Above shows STEP 7
assembled and completed

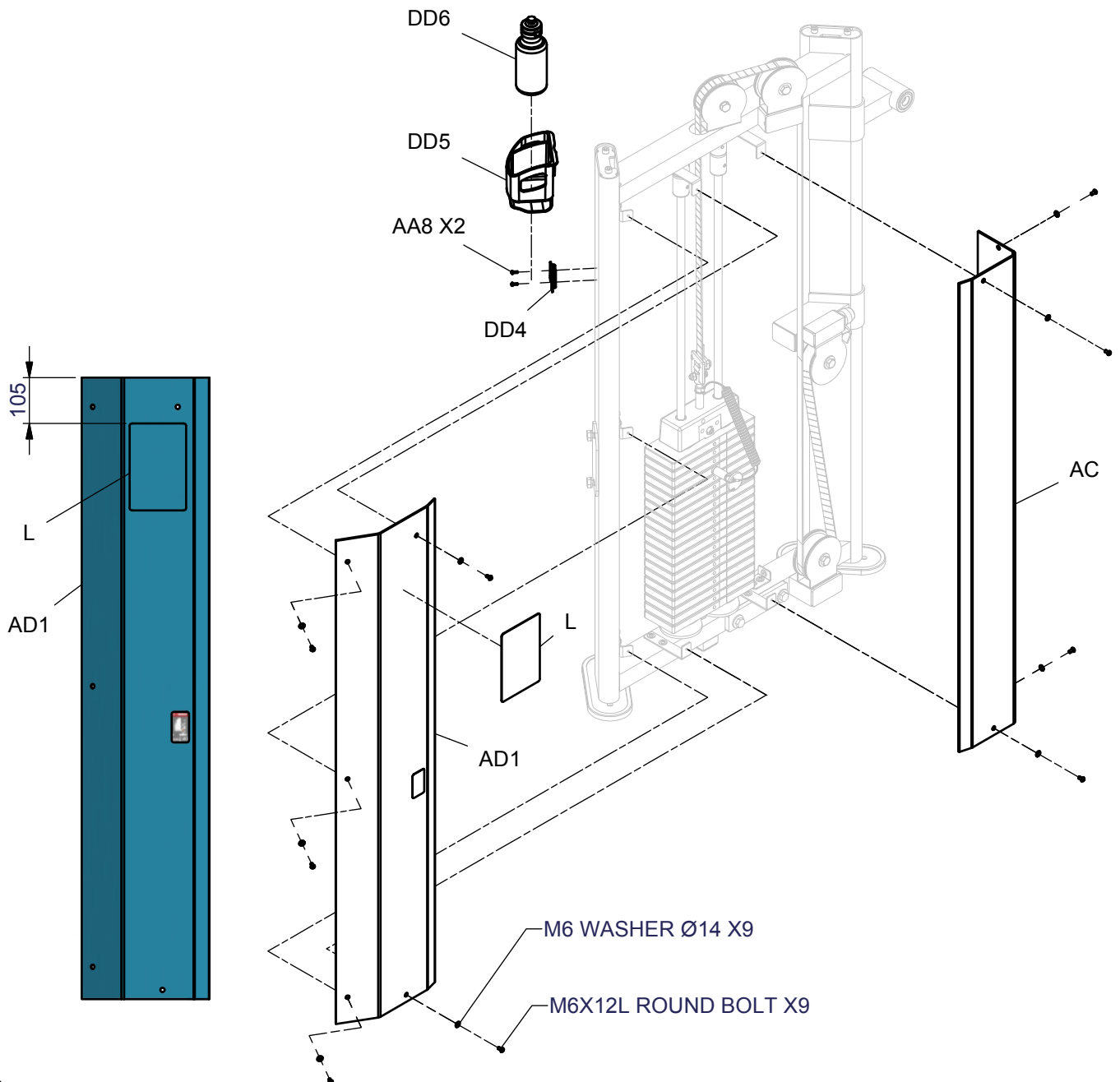

MHE1900 ASSEMBLY INSTRUCTIONS

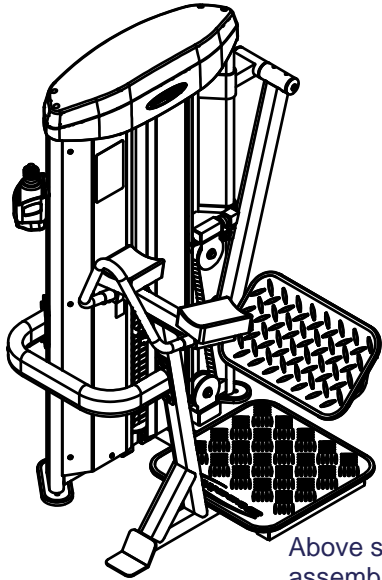

Above shows STEP 8 assembled and completed

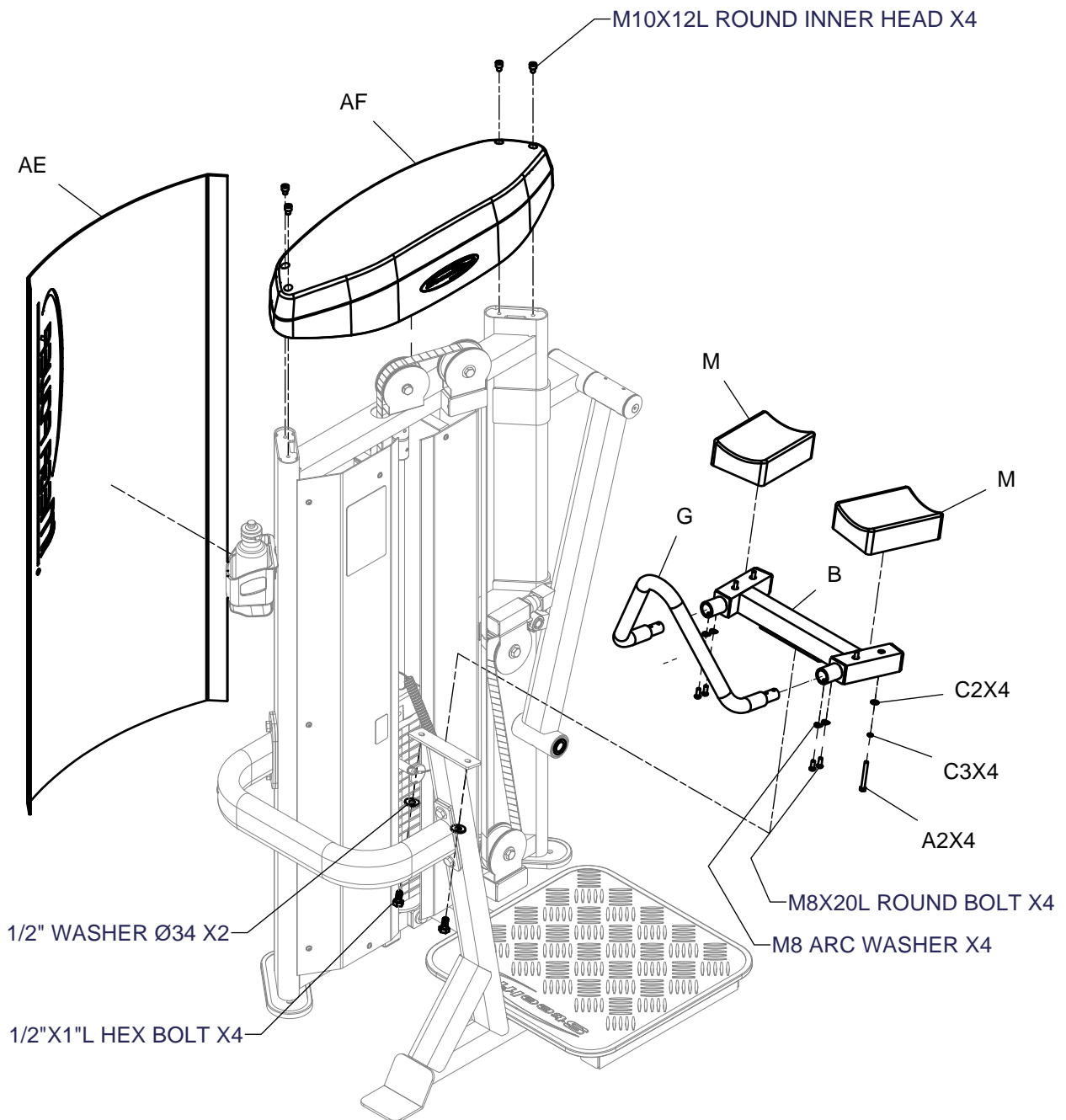

MEGA POWER series JUNGLE GYM series

project	Part number	Name	Specification	Quantity	Remark
1	38-200 CAP	round allen head	3/8"X2"L round allen head-CAP	1	
2	38-SPWAS 8732003	3/8" spring washer		1	
3	8210-216C	20 hole Selector Rod		1	
4	8250-166	pin	Ø7.9X137L	1	
5	8250-162	weight stack pin	Ø7X110L	1	
6	8400-010	10LB weight stack plate	102x22tx280L 10LB	20	
7	8400-033	top plate		1	

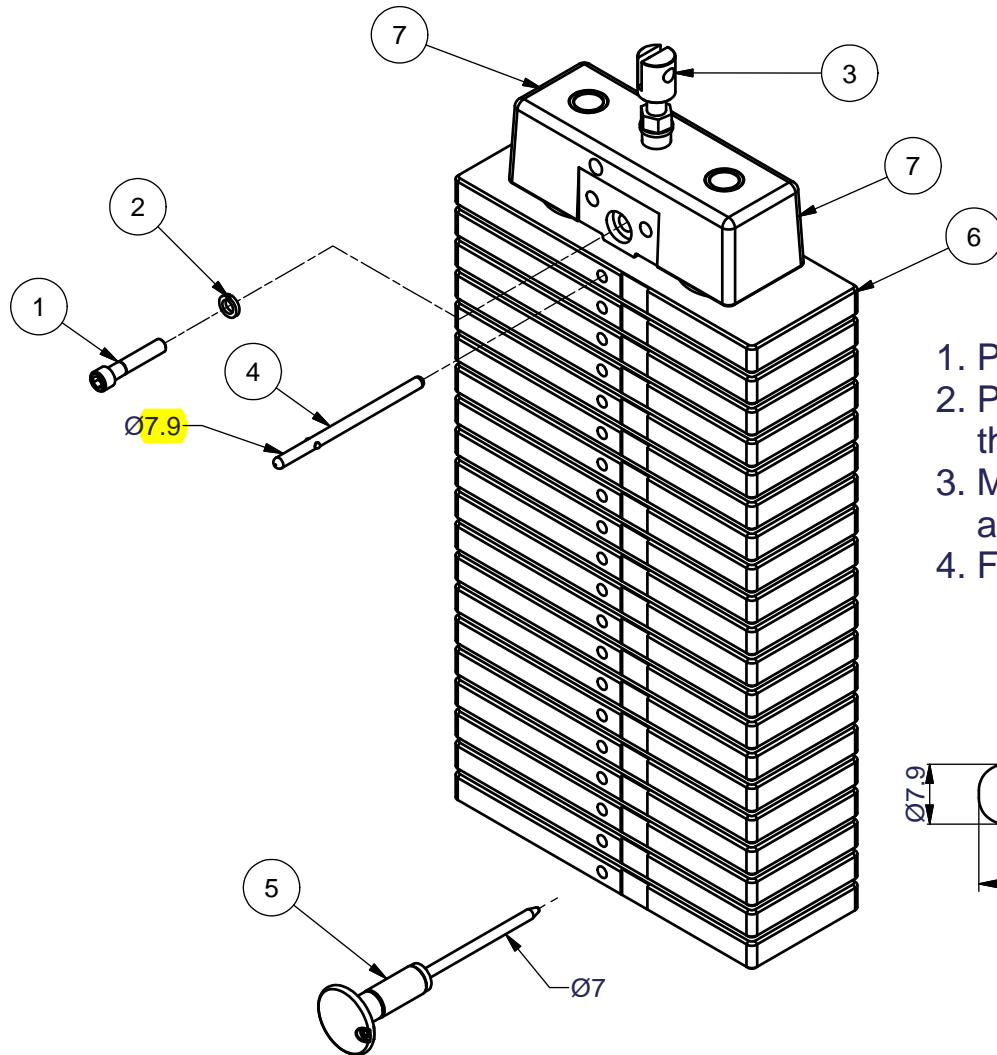

1. Place #4 - 8250-166 (pin) into the first weight plate.
2. Place #5 - 8250-162 (weight stack pin) into the the hole 20th of the weight stack.
3. Make sure #7 (top plate) cling to #6 (first weight plate) and fix in #1 - 3/8"X2"L screw and #2 - 3/8" spring washer.
4. Finally remove #5 - 8250-162 (weight stack pin) and use as usual.

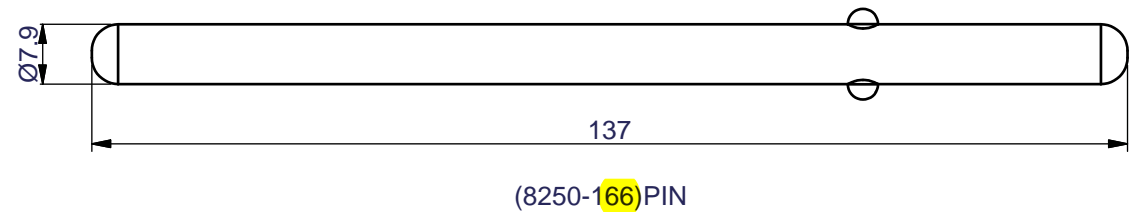

Guide on Selector Rod Adjustment

STEP 1

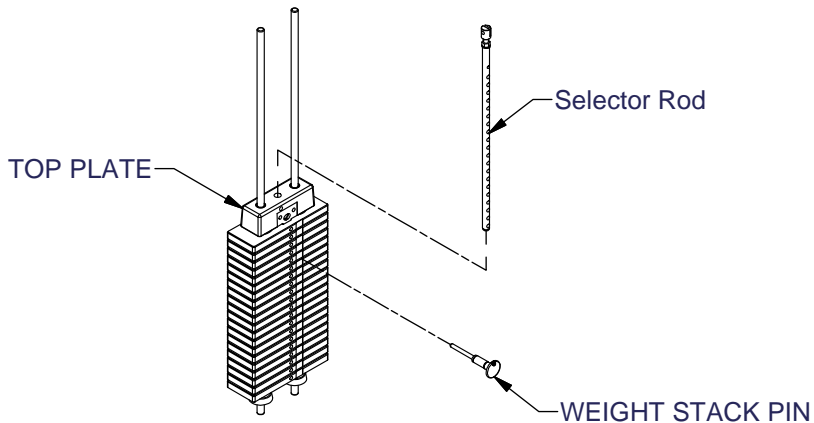

Step 1
Place Selector Rod into Top Plate.
Then put selector pin into the weight plate to fix the rod.

STEP 2

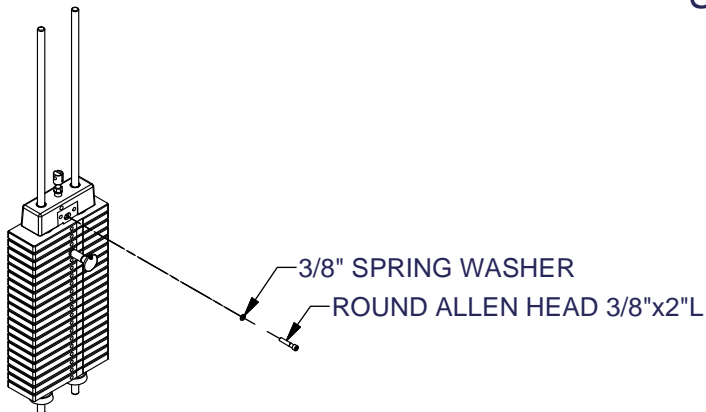

Step 2
Screw the 3/8"x2"L Round Allen Head
into Top Plate but not tighten it up.

STEP 3

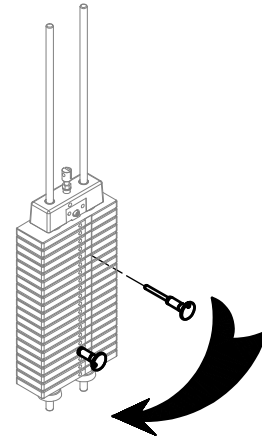

Step 3
Place the selector pin to each weight plate
(5,10,15,20....) to check the smoothness.

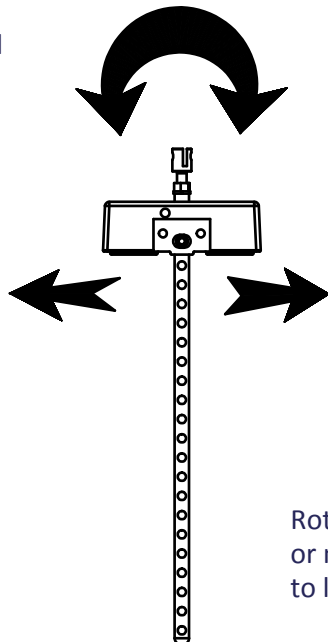

Rotate the Selector Rod slightly
or move the 3/8"x2"L Round Allen Head
to left and right and repeat Step 3.

ASSEMBLY INSTRUCTIONS

Adjust Flat Belt Steps

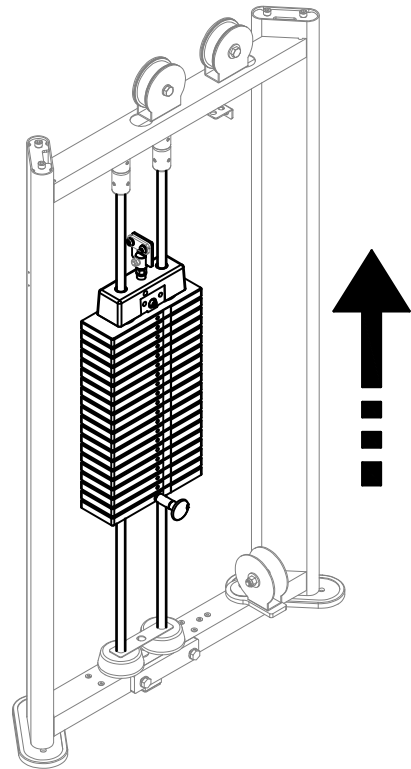
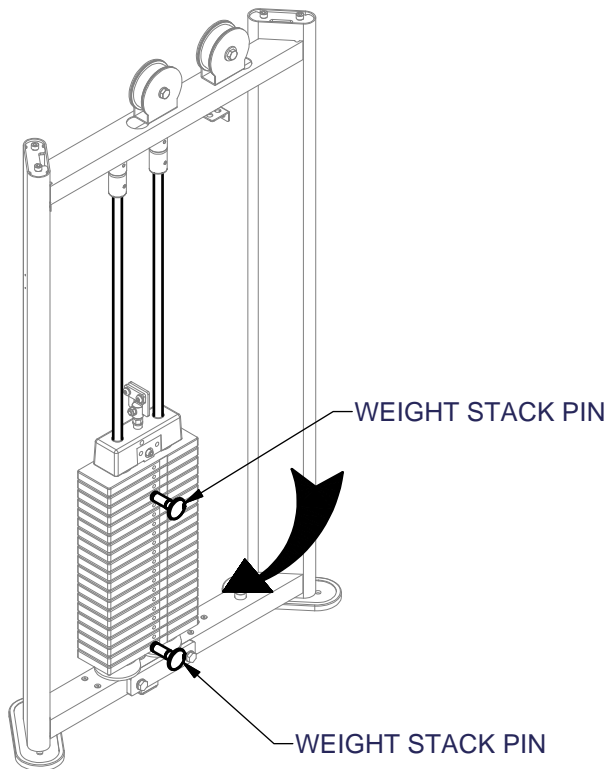

1. When installing flat belt, please put the weight stack pin into 4th weight stack. After installing flat belt, please put the weight stack pin into 20th weight stack.

2. When weight stack pin put into 20th weight stack, please do workout with the machine around 1 minute or 5-10 sets in order to extend the flat belt, flat belt will be loosed a little bit.

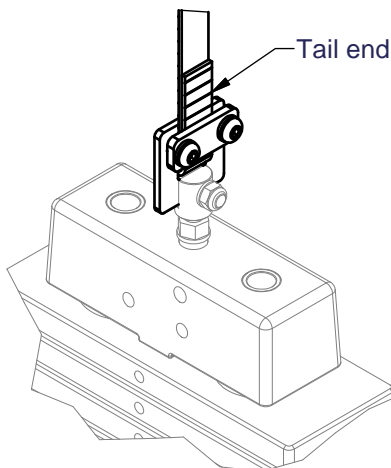

3. Pull end of flat belt as drawing showed to make the flat belt be tightened.
(After using the machine 3 months to 6 months, please check flat belt. If the flat belt is loosed, please follow this step to tighten the belt again.)