

MEGA POWER

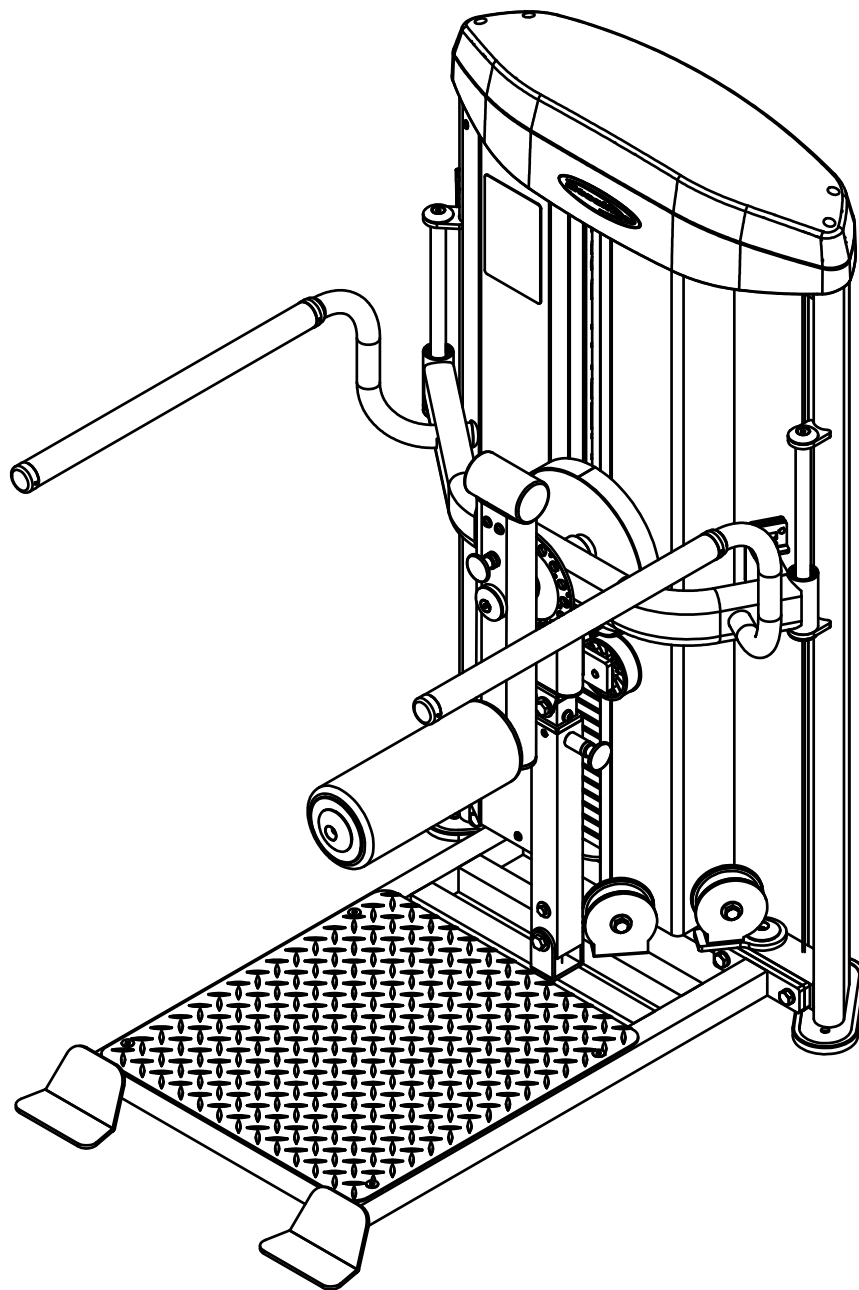

**Steelflex**

JOONG CHENN INDUSTRY CO., LTD.

Sales Office:

3F28, No.5, Shin-Yi Rd., Sec. 5, Taipei, Taiwan 110 R.O.C.

Tel: 886-2-27209980

Fax: 886-2-27229750

[www.steelflexfitness.com](http://www.steelflexfitness.com)

MMH-1500.4 OWNER'S MANUAL

# MMH-1500 ASSEMBLY INSTRUCTIONS

## HARDWARE ILLUSTRATION

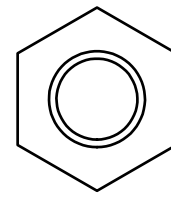
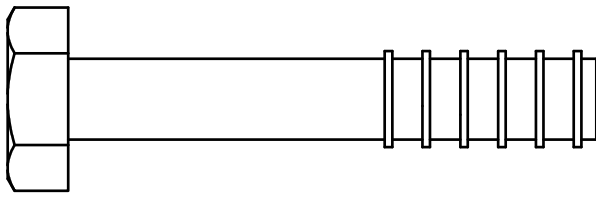

(A1)HEX BOLT 1/2"x2-3/4"L PARTIAL THREAD QTY.1

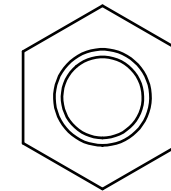
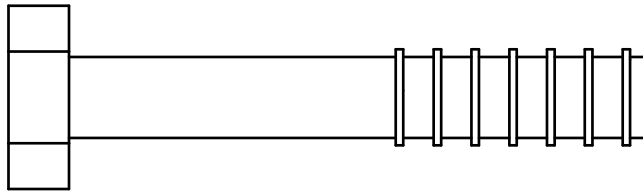

(A2)HEX BOLT 1/2"x3"L PARTIAL THREAD QTY.1

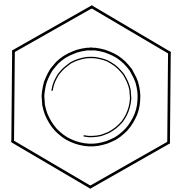
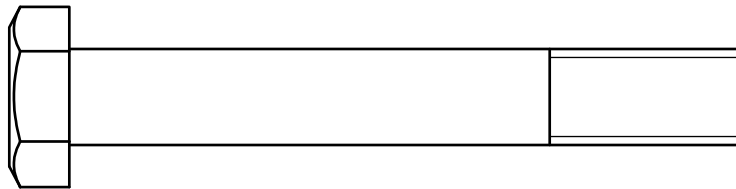

(A3)HEX BOLT 1/2"x3-1/2"L PARTIAL THREAD QTY.1

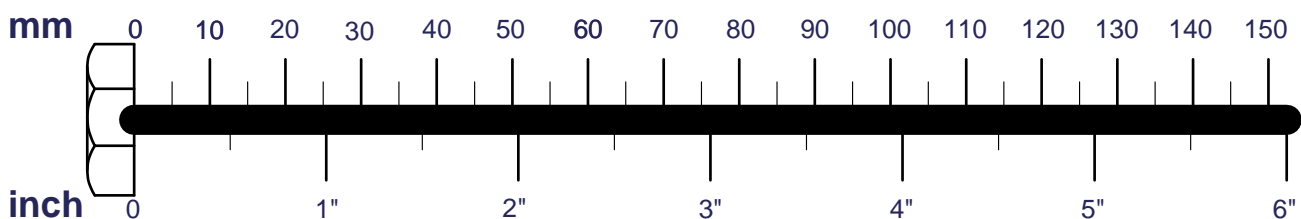

# MMH-1500 ASSEMBLY INSTRUCTIONS

## FRAME HARDWARE ILLUSTRATION FOR DOOR

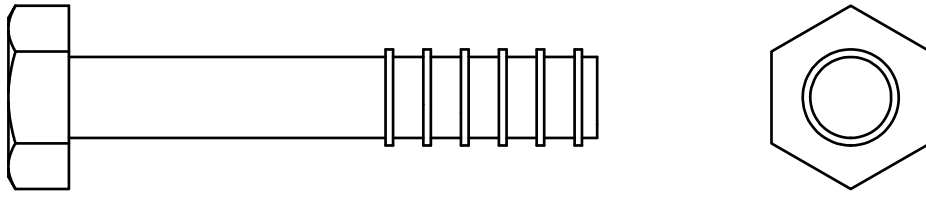

(A5)HEX BOLT 1/2"x2-3/4"L PARTIAL THREAD QTY.6

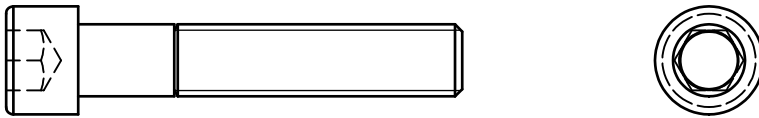

(A6)ROUND ALLEN HEAD 3/8"x2"L PARTIAL THREAD QTY.1



(A7)ROUND ALLEN HEAD M6X16L PARTIAL THREAD QTY.16

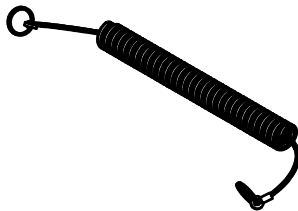

(A8)ELASTIC BELT (F920003) QTY.1

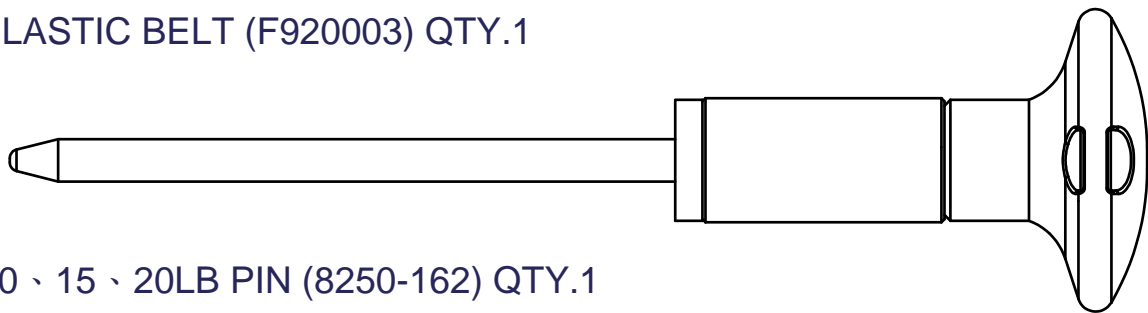

(A9)10 、 15 、 20LB PIN (8250-162) QTY.1

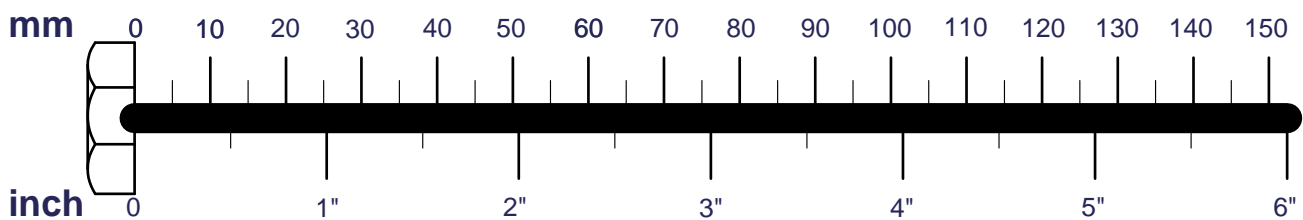

# MMH-1500 ASSEMBLY INSTRUCTIONS

## FRAME HARDWARE ILLUSTRATION FOR DOOR

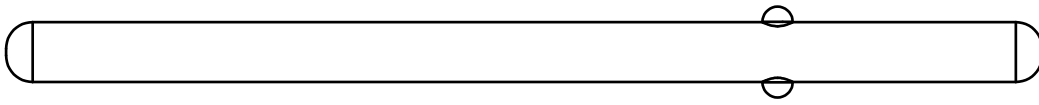

(A10) Ø5/16" FIXED PIN (8250-166) QTY.1

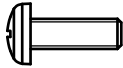

(A11) ROUND HEAD PHILLIPS M4X12L PARTIAL THREAD QTY.2

## HARDWARE ILLUSTRATION

## FRAME HARDWARE ILLUSTRATION FOR DOOR

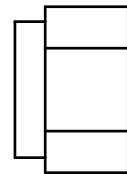
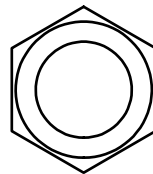
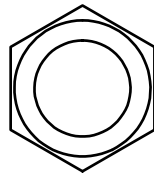
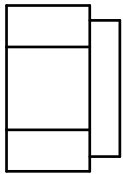

(B1) NYLON LOCK NUT 1/2" QTY.2

(B2) NYLON LOCK NUT 1/2" QTY.6

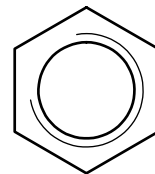
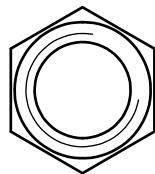
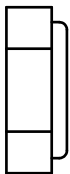

(B4) NYLON LOCK NUT 1/2" X 8H QTY.1

(B3) LOCK NUT 1/2"-13UNC QTY.1

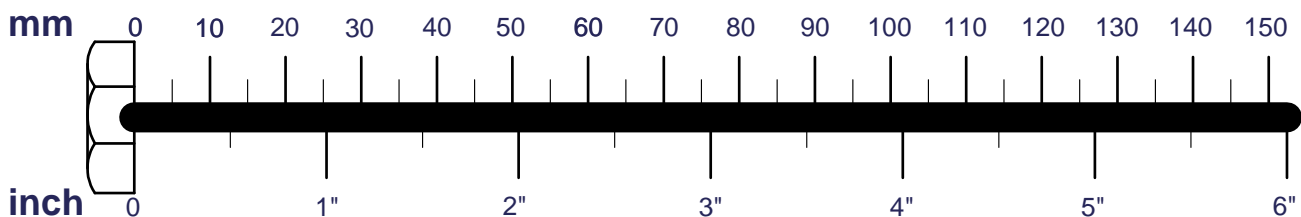

# MMH-1500 ASSEMBLY INSTRUCTIONS

## HARDWARE ILLUSTRATION

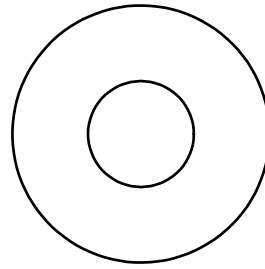
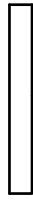
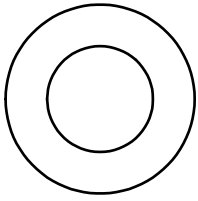

(C1) 1/2" (I.D.) FLAT WASHER Ø25 QTY.2

(C2) 1/2" (I.D.) FLAT WASHER Ø34 QTY.4

## FRAME HARDWARE ILLUSTRATION FOR DOOR

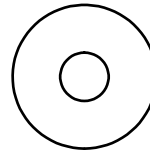
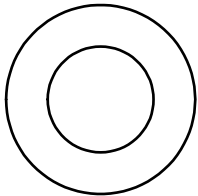

(C3) 1/2" (I.D.) FLAT WASHER Ø25 QTY.6

(C6) M6 (I.D.) FLAT WASHER Ø19 QTY.16

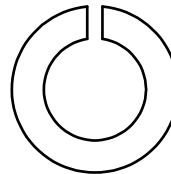
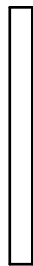
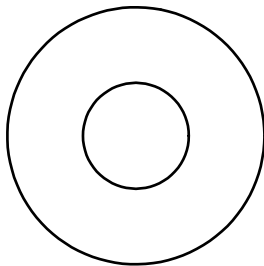

(C4) 1/2" (I.D.) FLAT WASHER Ø34 QTY.6

(C7) 1/2" SPRING WASHER QTY.1

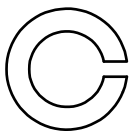

(C5) 3/8" SPRING WASHER QTY.1

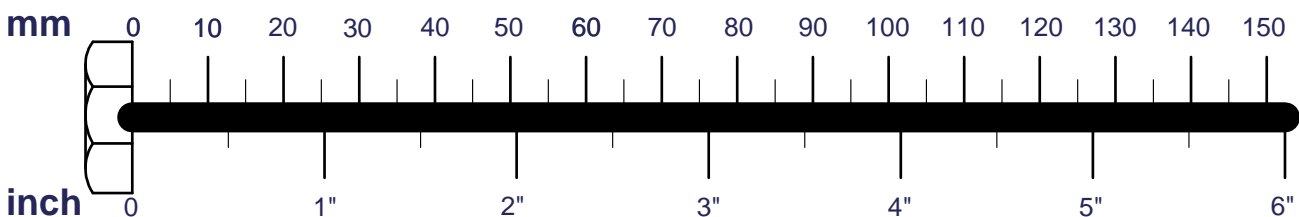

# MMH-1500 ASSEMBLY INSTRUCTIONS

## HARDWARE ILLUSTRATION

D2.Ø50 CAP COVER(8130-131)	-----	[5PCS]
D3.Ø60 CAP COVER(8130-231)	-----	[1PCS]
D3.Ø10X60L SHAFT (8210-156)	-----	[1PCS]
D4.Ø1" CU WASHER(8520-008)	-----	[2PCS]
D5.Ø38 END CAP(9211-099)	-----	[2PCS]
D7.Ø115 PULLEY(9213-042B)	-----	[1PCS]
D8.Ø110 PULLEY(9213-043A)	-----	[2PCS]
D9.5780mm BELT(FMMH15001)	-----	[1PCS]
D10.EXERCISE CHART (9420-111)	-----	[1PCS]
D12.□45 END CAP(9211-004)	-----	[1PCS]
D13.□60 END CAP(9211-049)	-----	[1PCS]
D27. Ø120XØ52X3t NYLON WASHER (9214-039)	-----	[2PCS]
D28.Ø76 CAP COVER(8130-236)	-----	[1PCS]

D2



D3



D4



D5



D7

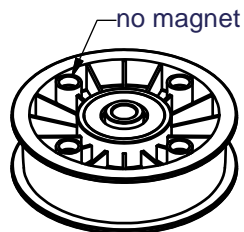

D8

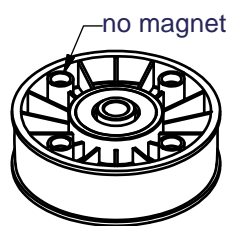

D9

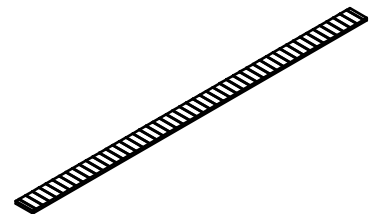

D10

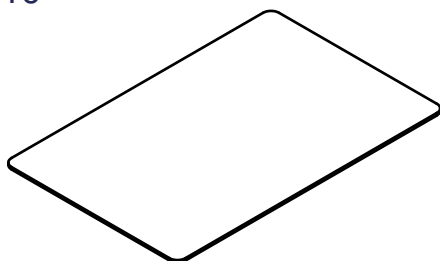

D12



D13

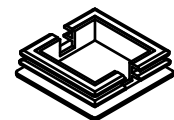

D27

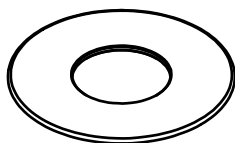

D28



# MMH-1500 ASSEMBLY INSTRUCTIONS

## FRAME HARDWARE ILLUSTRATION

D14.3/4" SHAFT COLLAR(9211-147)-----	[2PCS]
D15.Ø4" RUBBER PAD(9310-017)-----	[2PCS]
D16.108X263 RUBBER PAD(9310-075)-----	[2PCS]
D18.Ø115 PULLEY(9213-042B)-----	[6PCS]
D19.BOTTLE BRACKET(8388-025)-----	[1PCS]
D20.BOTTLE RACK(9260-320)-----	[1PCS]
D21.BOTTLE(9260-123)-----	[1PCS]

D14

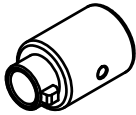

D15

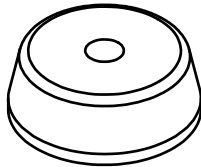

D16

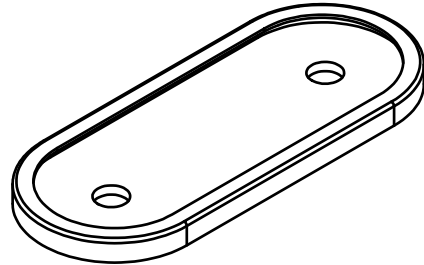

D18

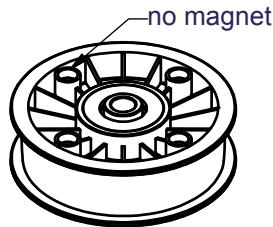

D19



D20

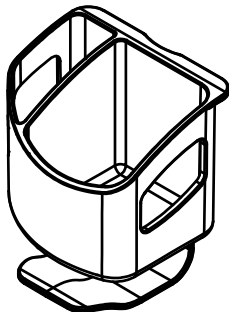

D21



# MMH-1500 ASSEMBLY INSTRUCTIONS

## FRAME HARDWARE ILLUSTRATION

D24.TOP PLATE(8400-033)-----[1PCS]  
D25.3/4" SHAFT COLLAR(9211-167)-----[2PCS]  
D26.Selector Rod(8210-216)-----[1PCS]

D24

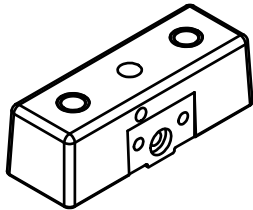

D25

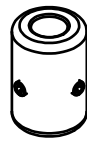

D26

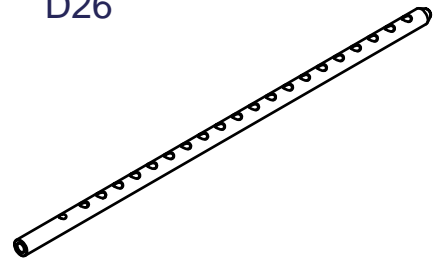

# MMH-1500 ASSEMBLY INSTRUCTIONS

## PARTS ILLUSTRATION SHEET

A1[1PCS]

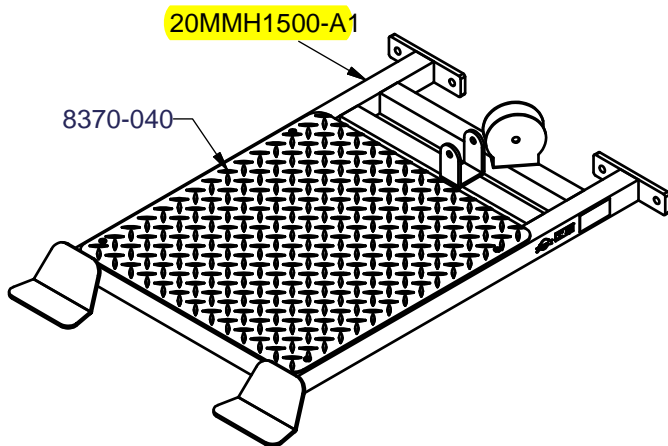

B[1PCS]

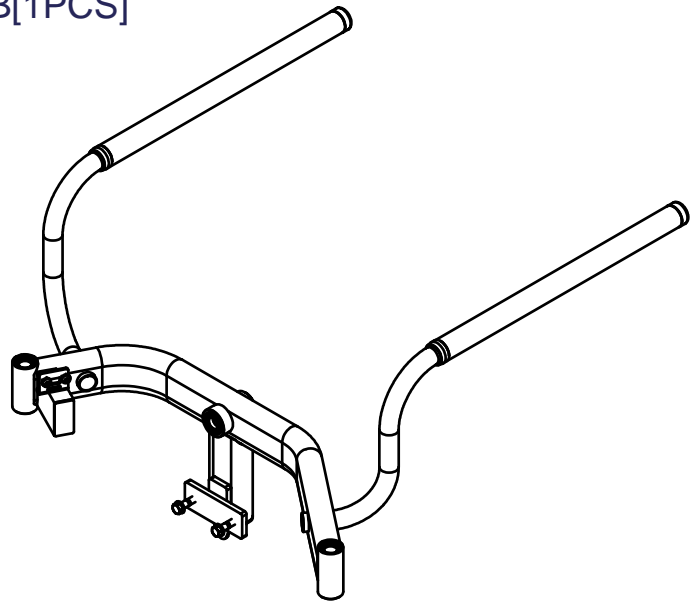

C1[1PCS]

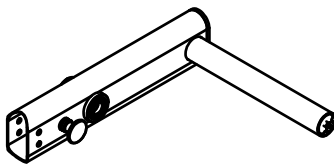

D[1PCS]

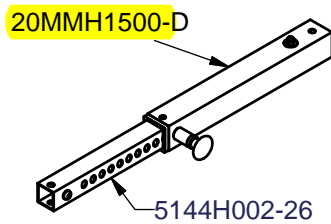

E[1PCS]

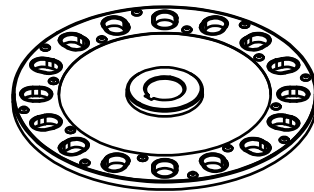

F[1PCS]

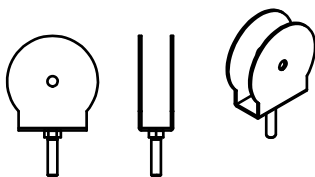

G[1PCS]  
6680-015

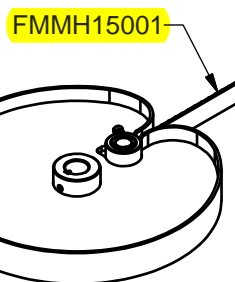

H[1PCS]  
280277

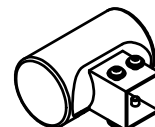

I[2PCS]  
8220-198  
Ø25X300L

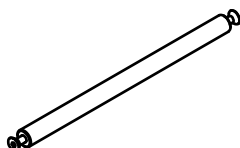

J[1PCS]  
8220-199  
Ø25X250L

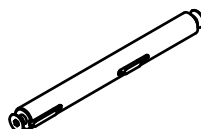

# MMH-1500 ASSEMBLY INSTRUCTIONS

## PARTS ILLUSTRATION SHEET

L1[1PCS]  
9161-080  
Ø150X360L

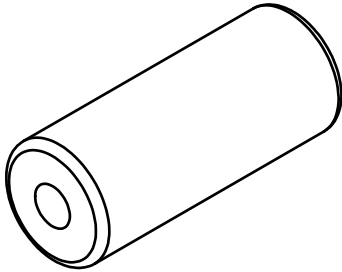

# MMH-1500 ASSEMBLY INSTRUCTIONS

## FRAME PARTS ILLUSTRATION SHEET

G1[1PCS]

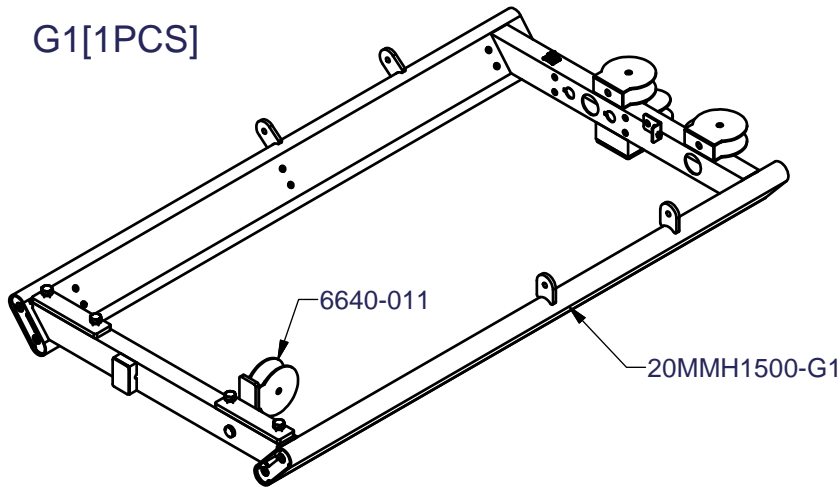

AB1[1PCS]  
9220-052

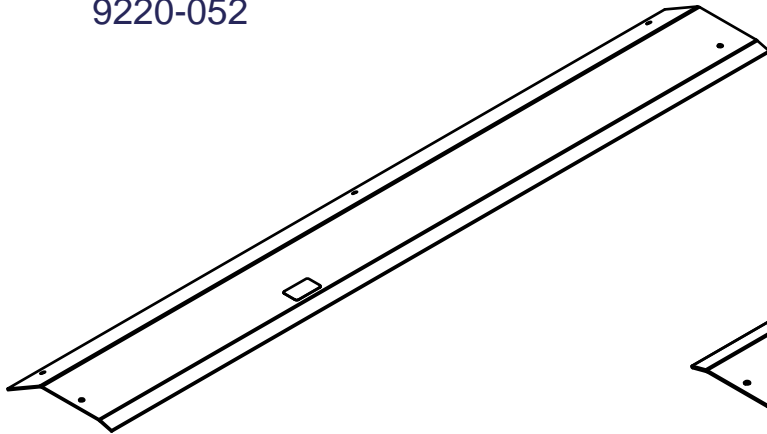

AC[1PCS]  
9220-016

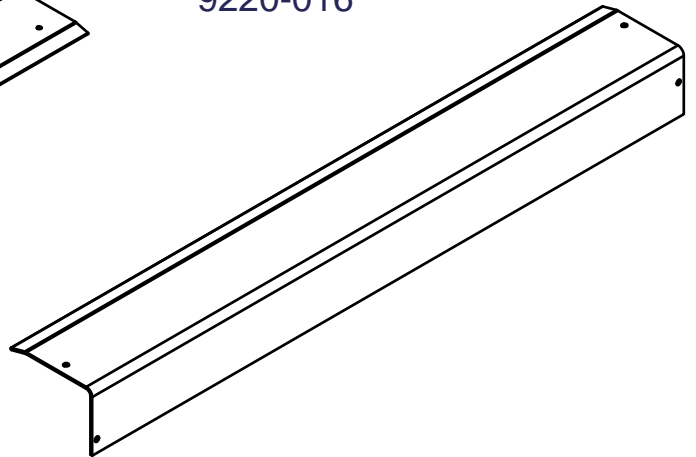

AD[1PCS]  
9220-023

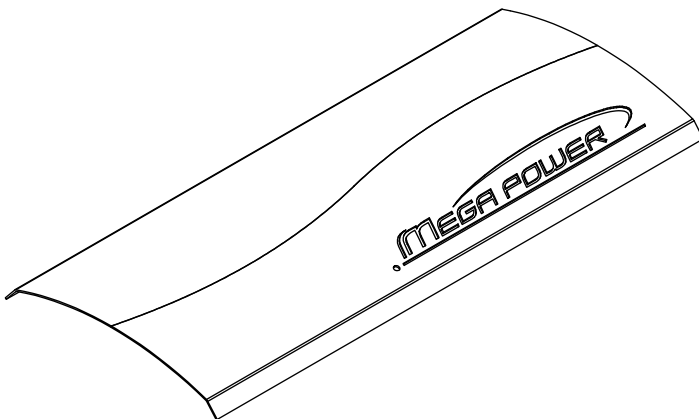

AE[1PCS]  
9211-148

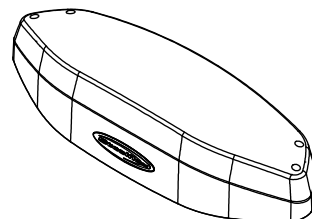

# MMH-1500 ASSEMBLY INSTRUCTIONS

## FRAME PARTS ILLUSTRATION SHEET

AF[4PCS]  
8331-057

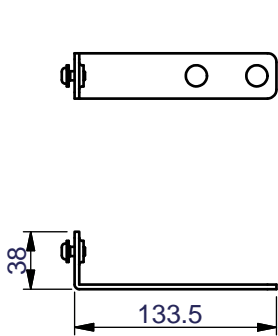

AG[1PCS]  
8311-117

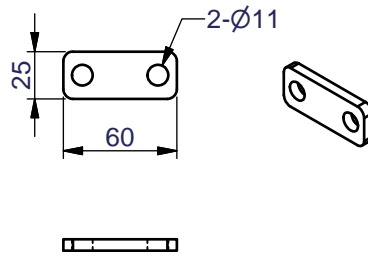

AH[3PCS]  
8331-058

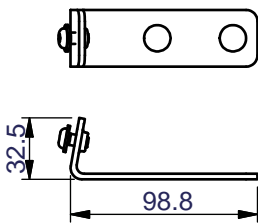

AI[2PCS]  
8313-144

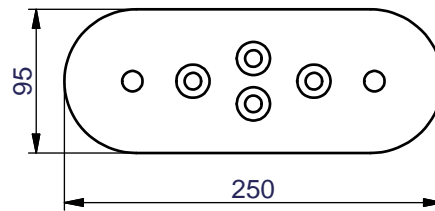
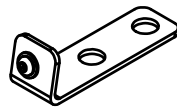

AK1[2PCS]  
8280-042  
Ø3/4"X1433L

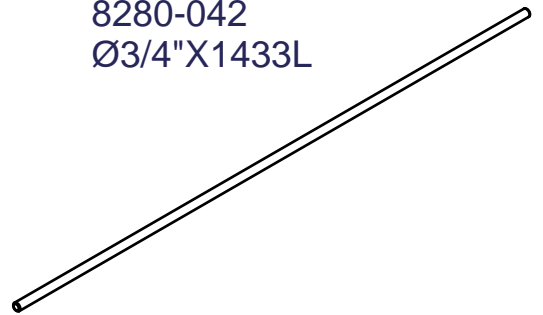

AL[1PCS]  
8331-056

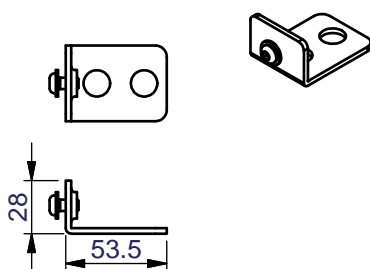

AP[1PCS]  
8311-194

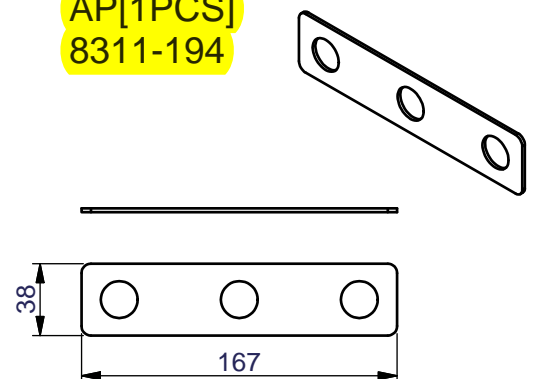

# MMH-1500 ASSEMBLY INSTRUCTIONS

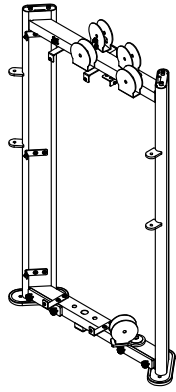

Above shows STEP 1  
assembled and completed

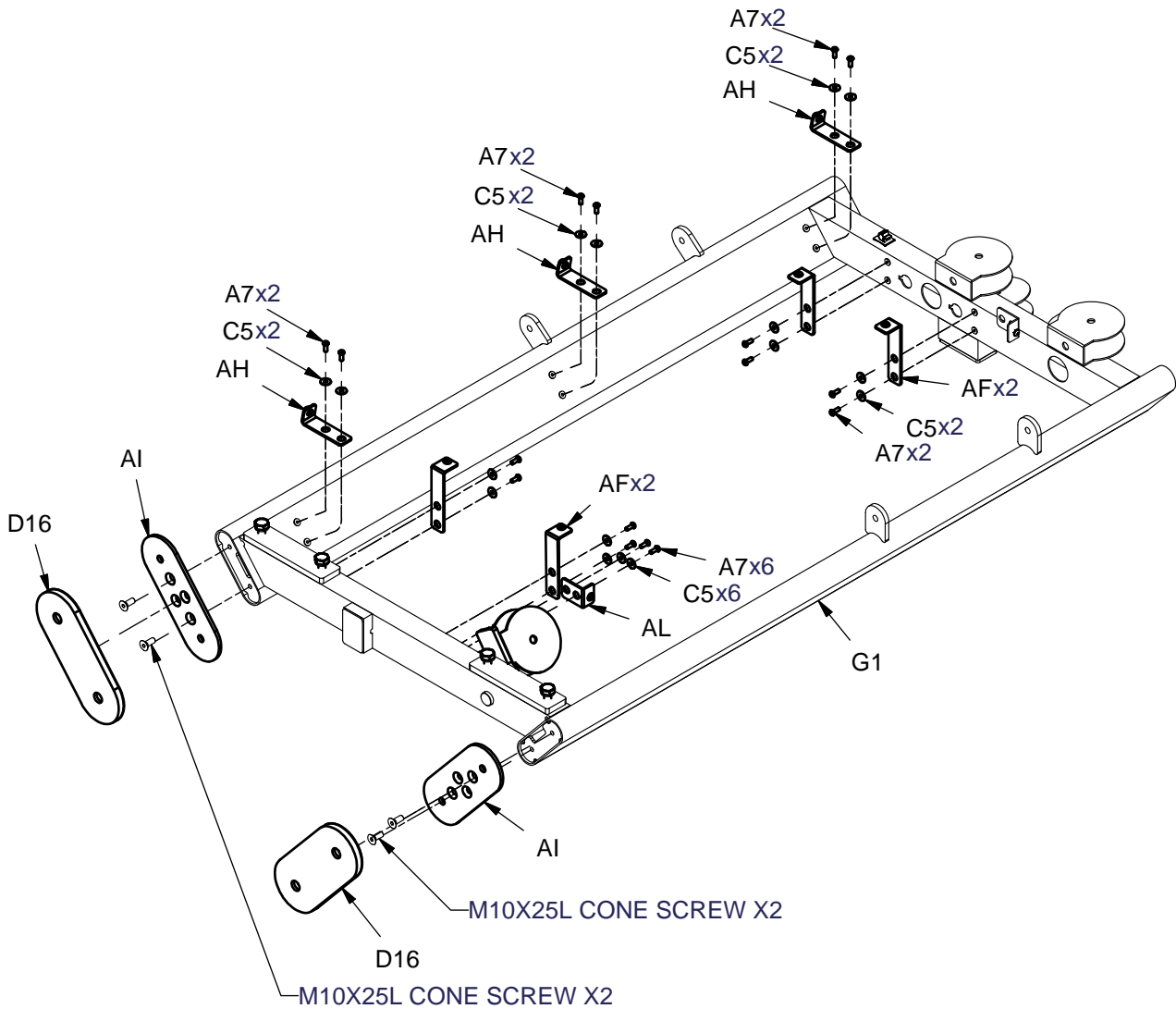

# MMH-1500 ASSEMBLY INSTRUCTIONS

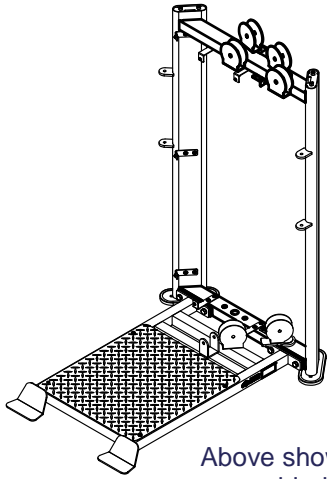

Above shows STEP 2 assembled and completed

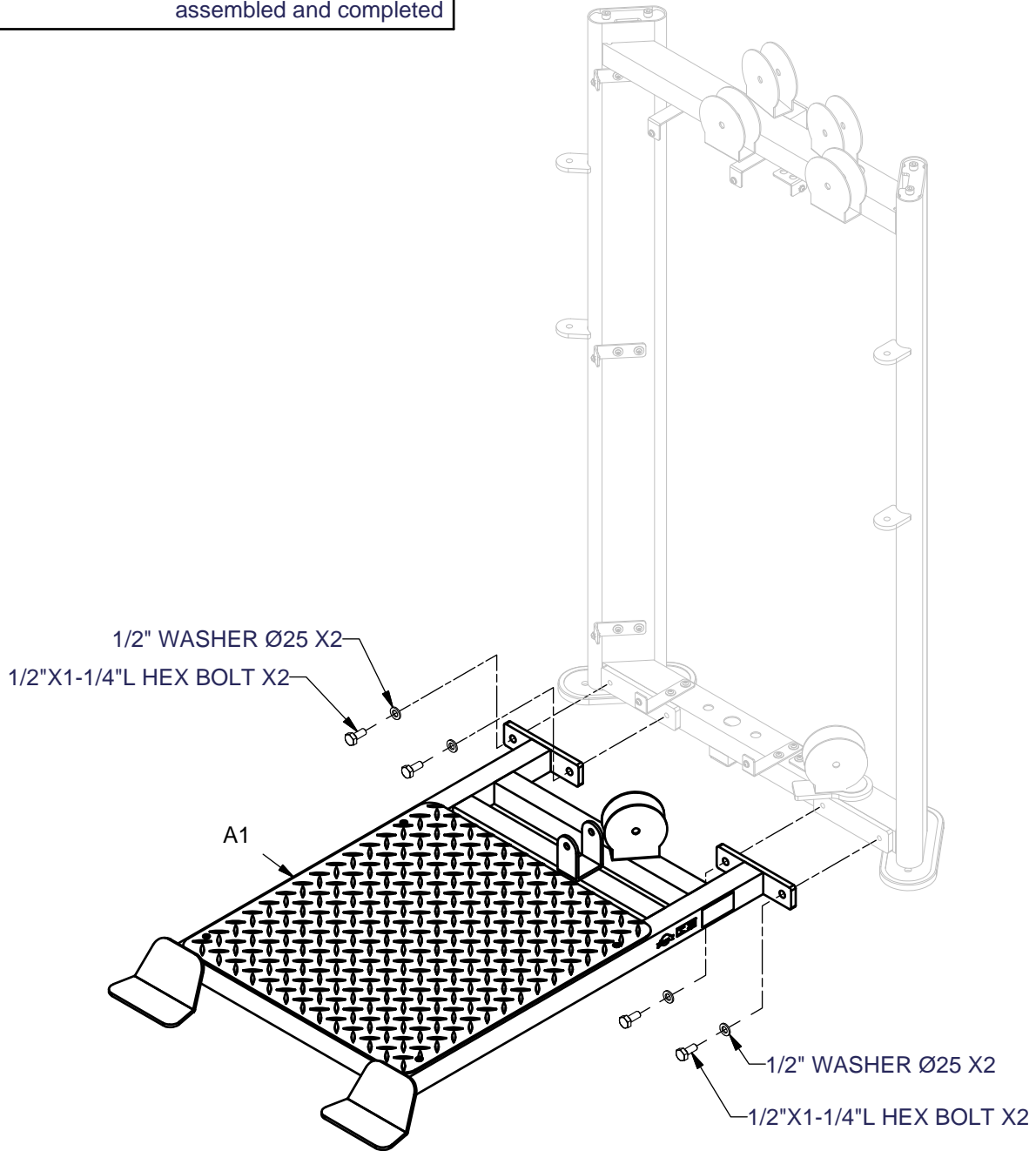

# MMH-1500 ASSEMBLY INSTRUCTIONS

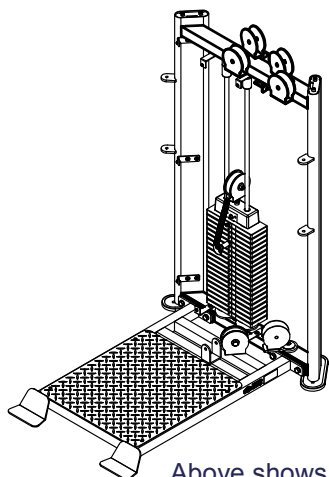

Above shows STEP 3 assembled and completed

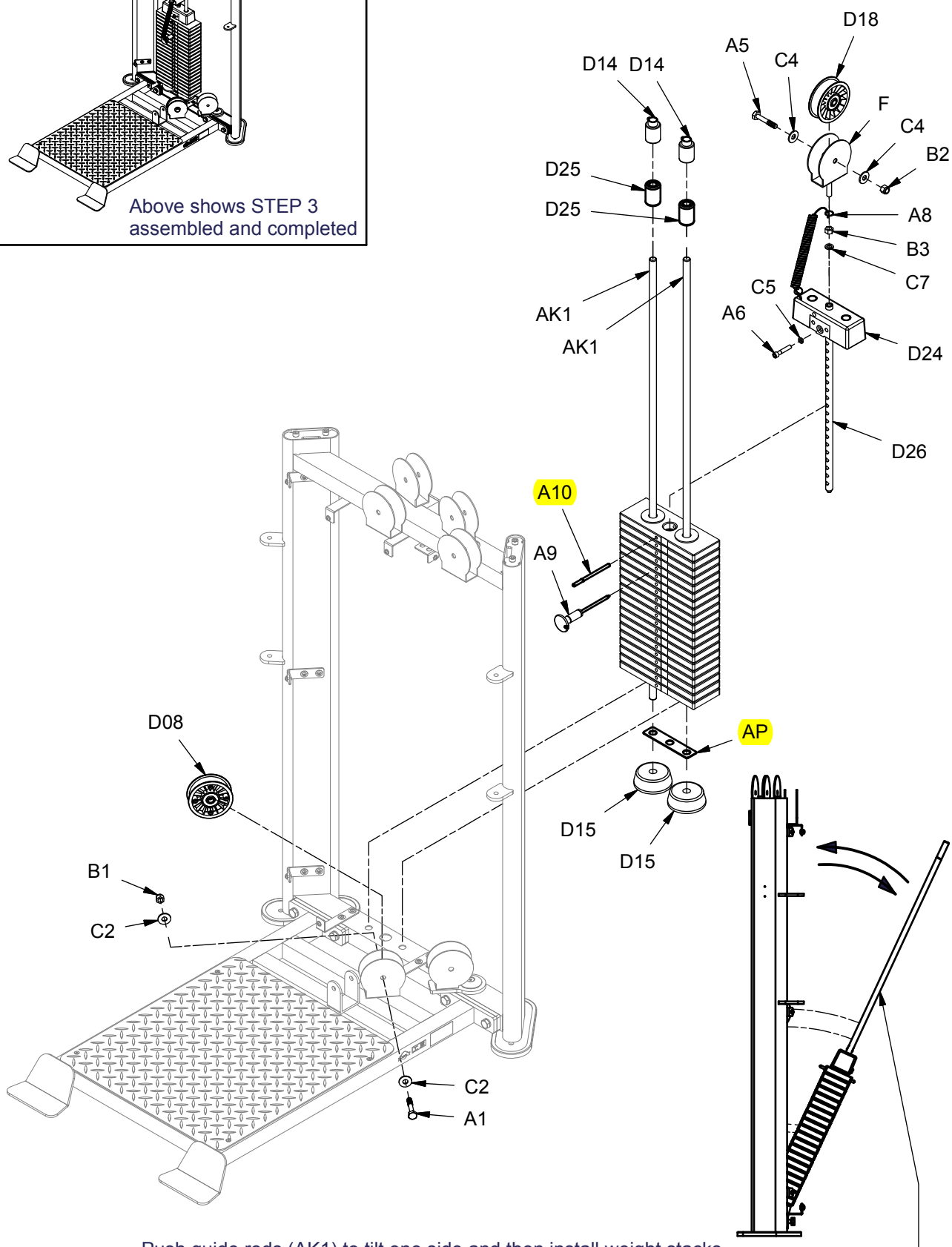

Push guide rods (AK1) to tilt one side and then install weight stacks. Once finishing the weight stack installation, pull guide rods (AK1) back and continue setup D24 → D14

# MMH-1500 ASSEMBLY INSTRUCTIONS

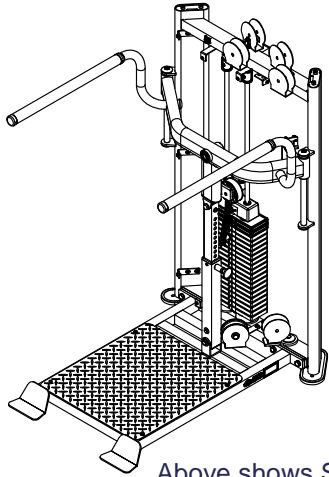

Above shows STEP 4 assembled and completed

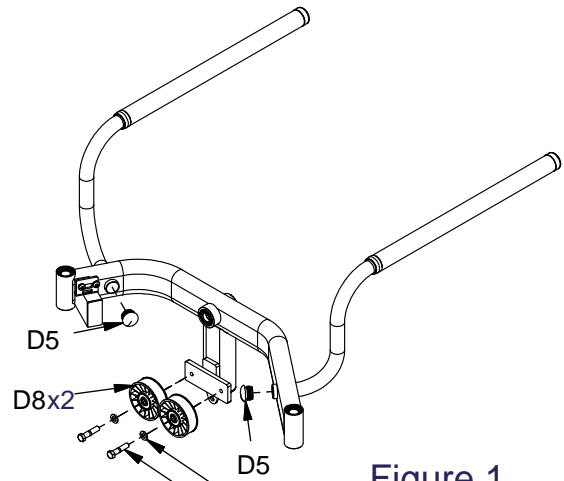
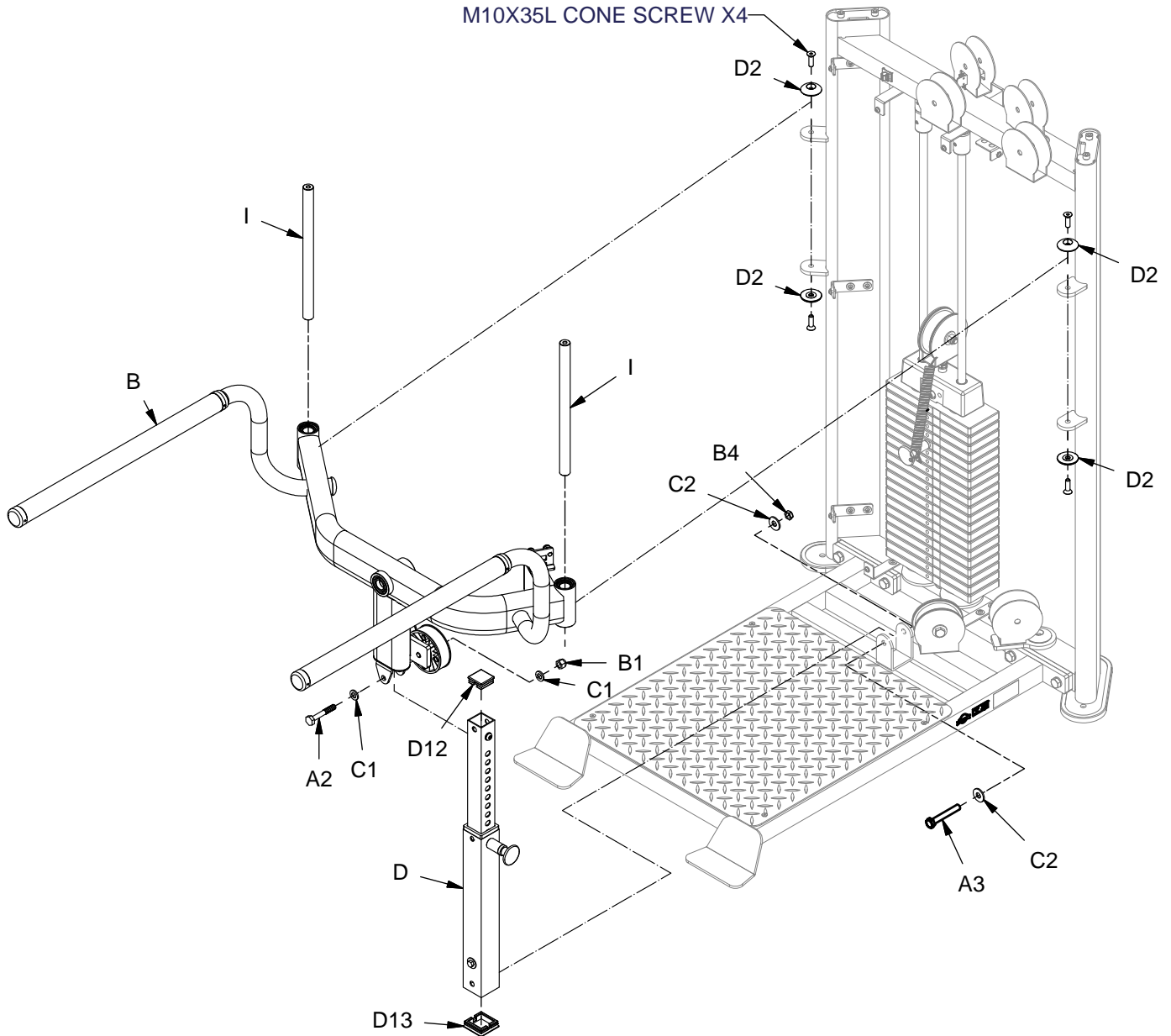

Figure 1

1/2"X2-1/4" HEX BOLT X2  
1/2" WASHER Ø25 X2

M10X35L CONE SCREW X4



# MMH-1500 ASSEMBLY INSTRUCTIONS

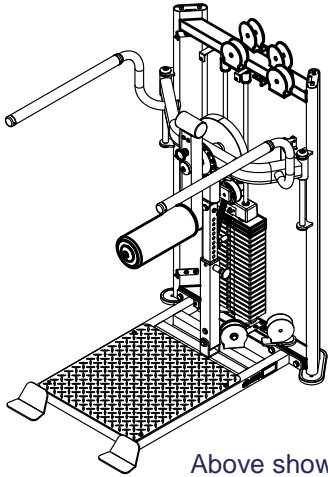

Above shows STEP 5 assembled and completed

Attention  
 \*:NEED TO LOOSEH BOTH ALLEN HEAD BOLT  
 IN ORDER TO REMOVE SHAFT

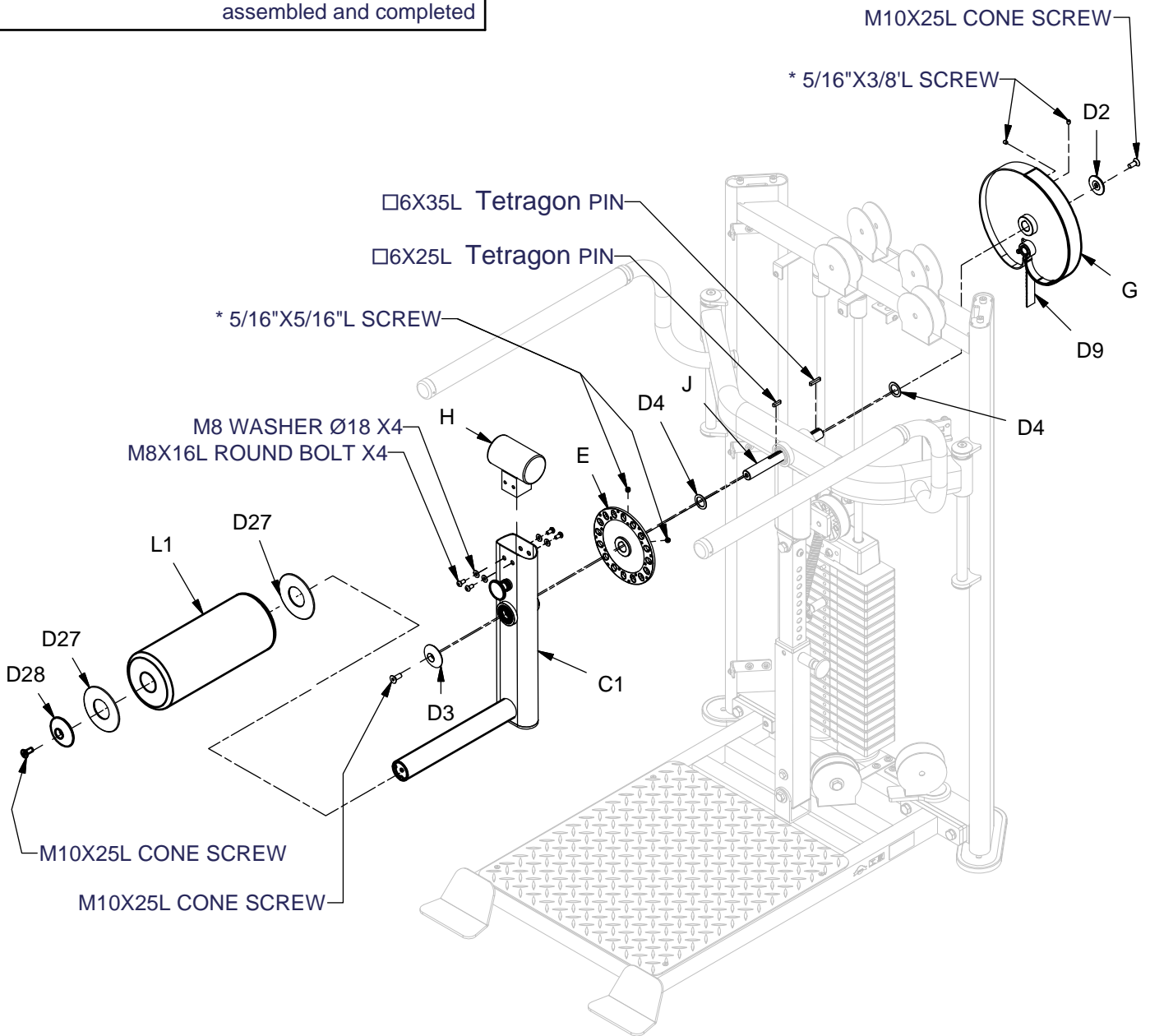

# MMH-1500 ASSEMBLY INSTRUCTIONS

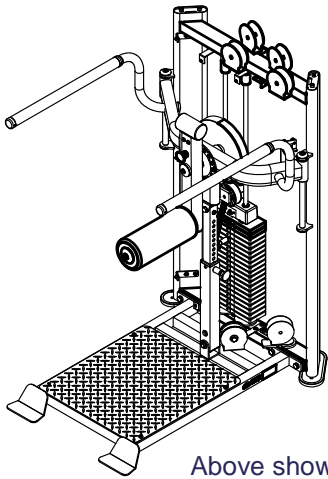

Above shows STEP 6 assembled and completed

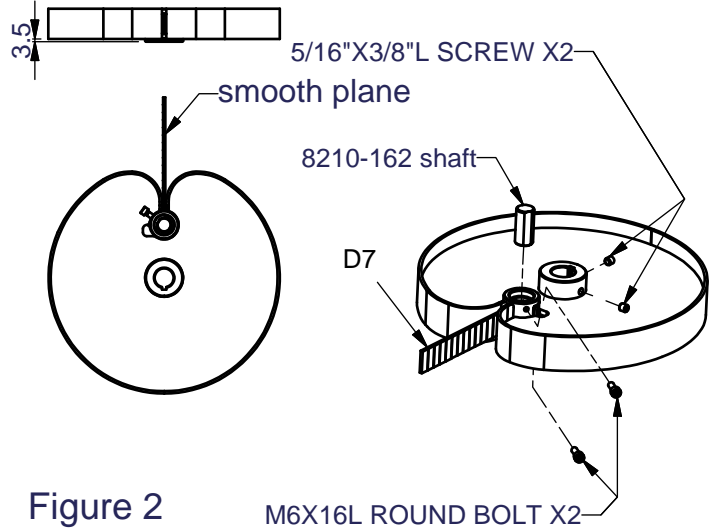
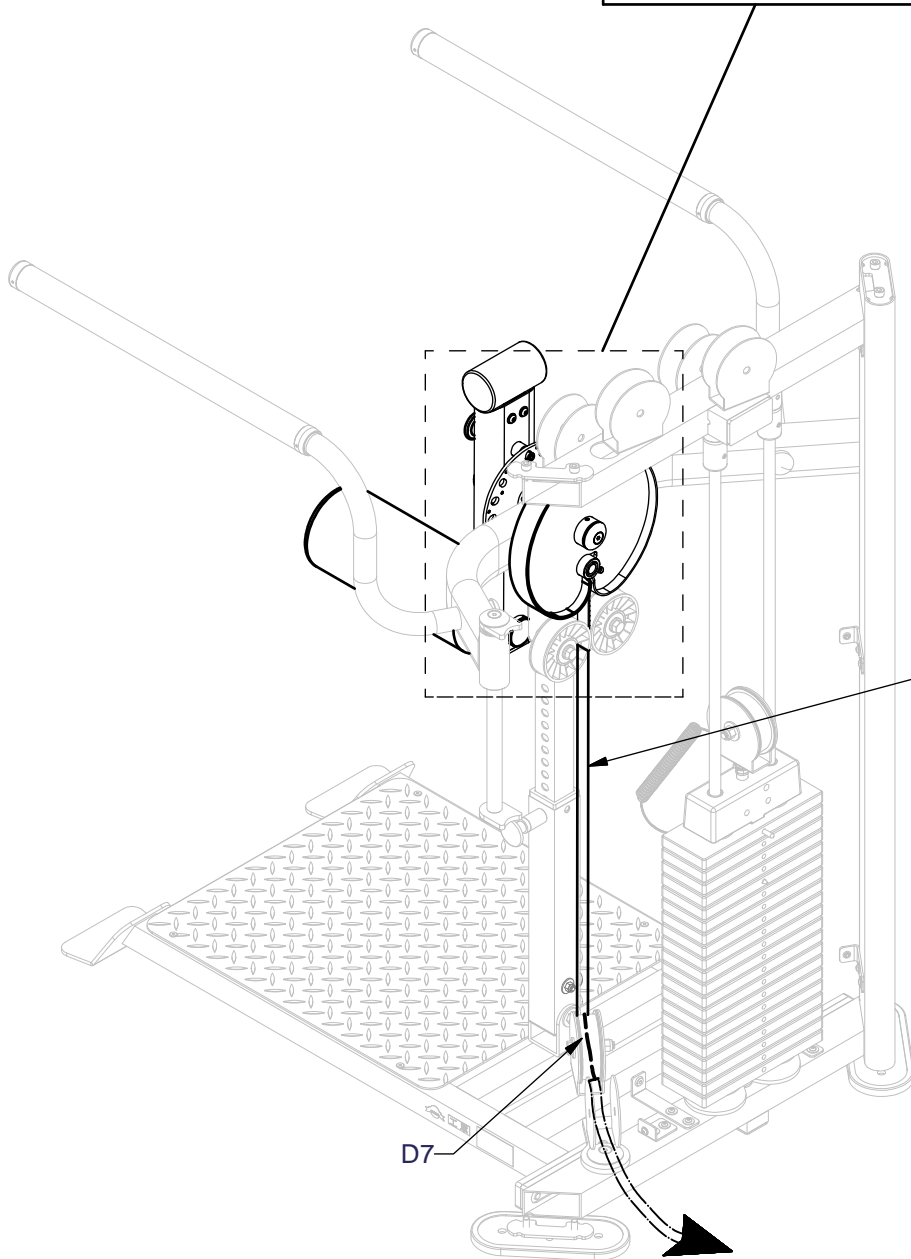

Figure 2



**NOTE:**

1. THE BELT SMOOTH SIDE SHOULD ATTACH ON PULLEY SURFACE , AND THE BELT SMOOTH SIDE WRAP AROUND THE BELT RETAINER SHAFT (B)
2. PLEASE BE SURE THE PRESSURE BETWEEN THE BELT CLAMPS (AG) DO NOT EXCEED 70 PSI

# MMH-1500 ASSEMBLY INSTRUCTIONS

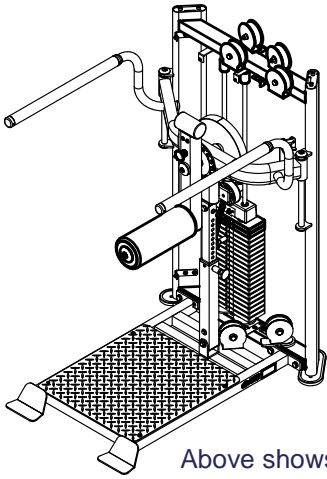

Above shows STEP 7 assembled and completed

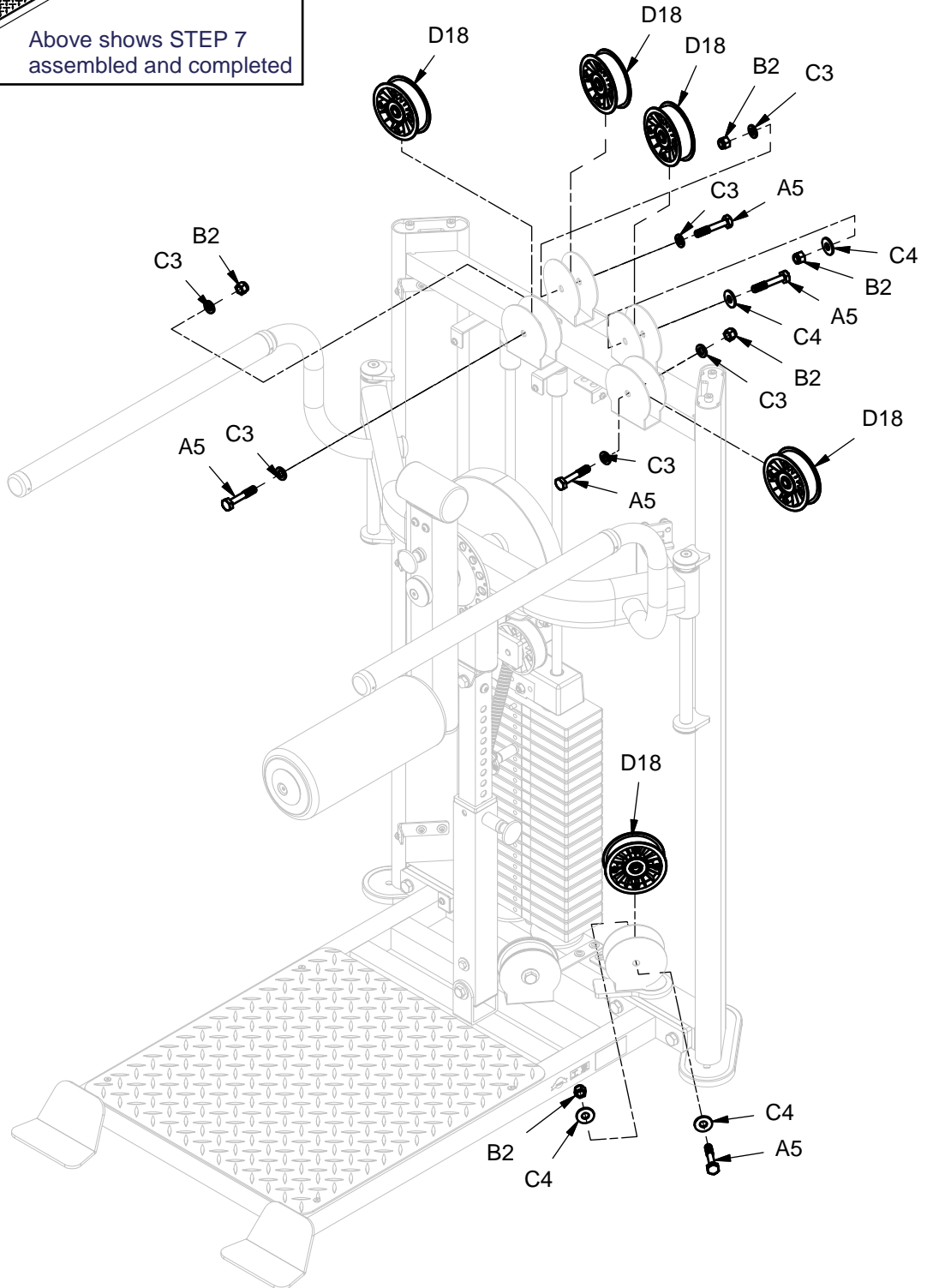

# MMH-1500 ASSEMBLY INSTRUCTIONS

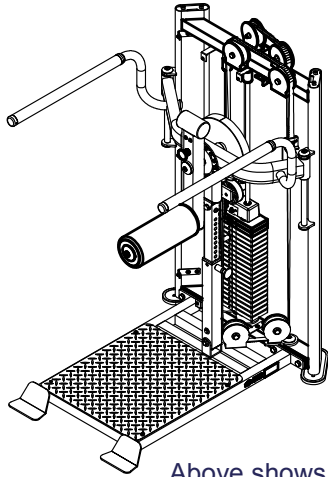

Above shows STEP 8 assembled and completed

**NOTE:**

1. THE BELT SMOOTH SIDE SHOULD ATTACH ON PULLEY SURFACE, AND THE BELT SMOOTH SIDE WRAP AROUND THE BELT RETAINER SHAFT (B)
2. PLEASE BE SURE THE PRESSURE BETWEEN THE BELT CLAMPS (AG) DO NOT EXCEED 70 PSI

# Equipment order 1→2→3→4→5→6

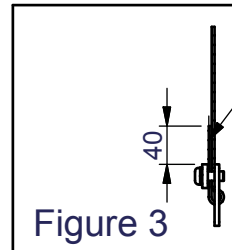

The belt should reserve 40mm extra length

Figure 3

The tread side should be outward

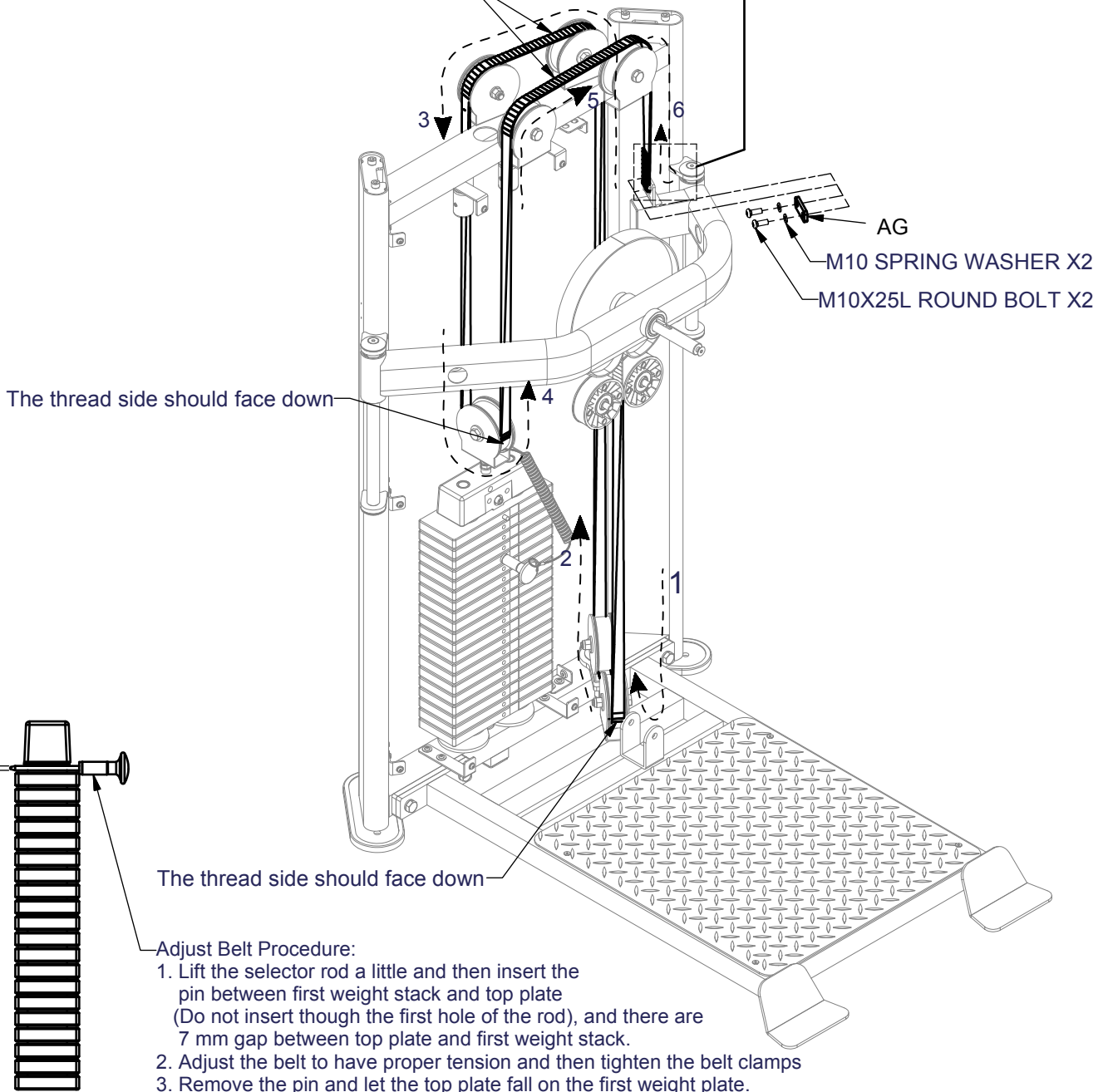

The thread side should face down

AG

M10 SPRING WASHER X2

M10X25L ROUND BOLT X2

The thread side should face down

**Adjust Belt Procedure:**

1. Lift the selector rod a little and then insert the pin between first weight stack and top plate (Do not insert through the first hole of the rod), and there are 7 mm gap between top plate and first weight stack.
2. Adjust the belt to have proper tension and then tighten the belt clamps
3. Remove the pin and let the top plate fall on the first weight plate.

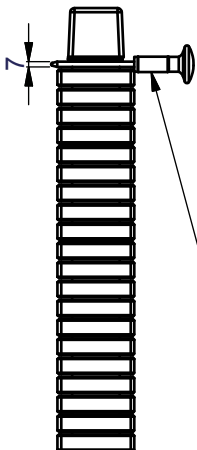

# MMH-1500 ASSEMBLY INSTRUCTIONS

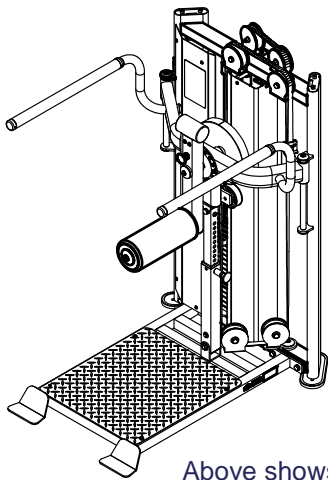

Above shows STEP 9 assembled and completed

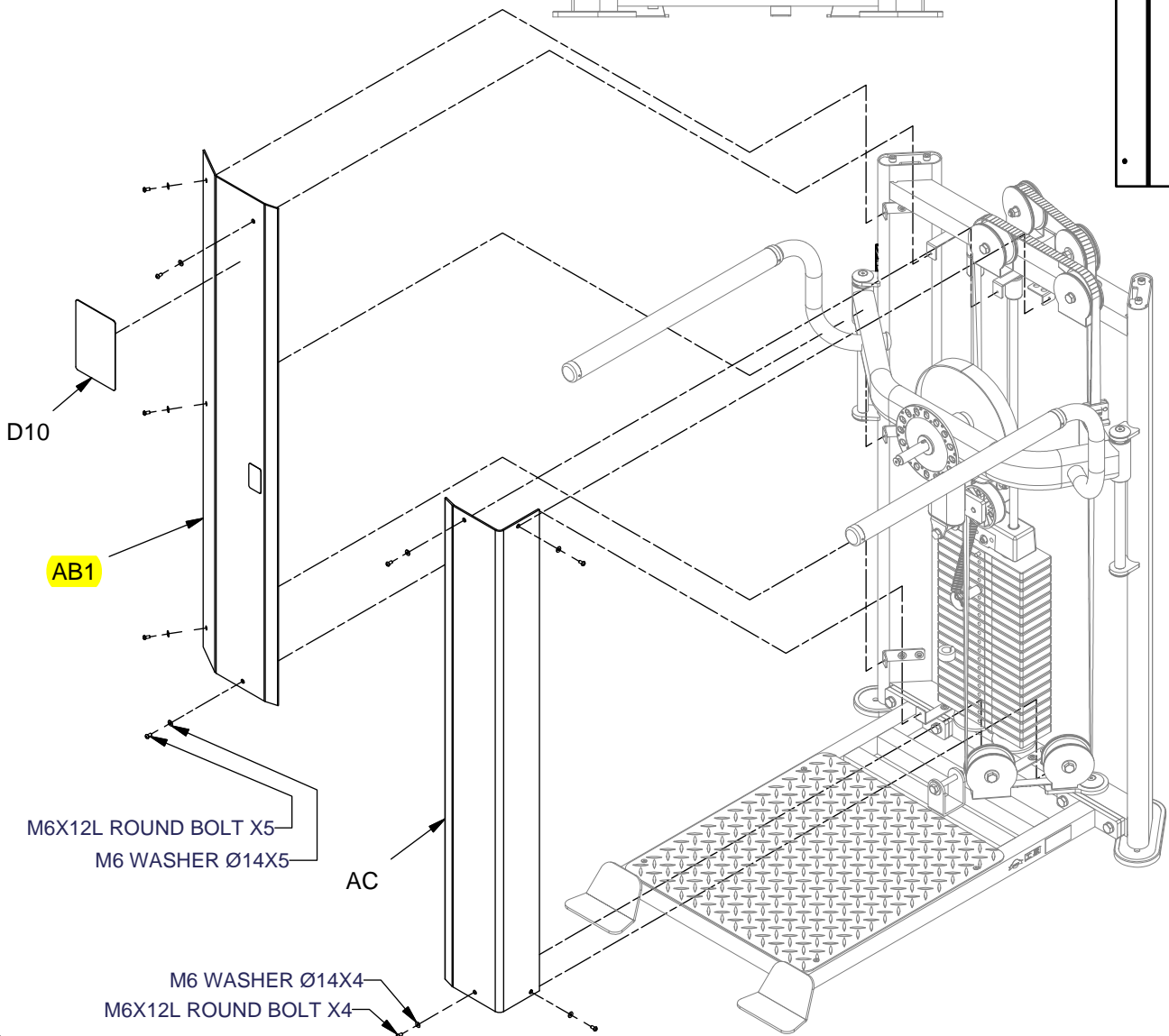
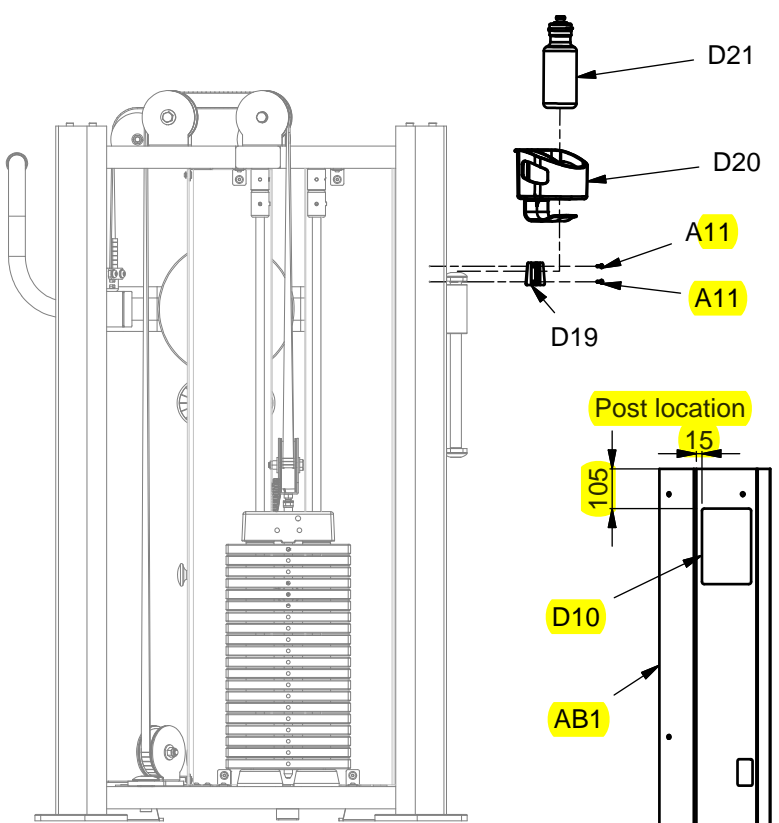

# MMH-1500 ASSEMBLY INSTRUCTIONS

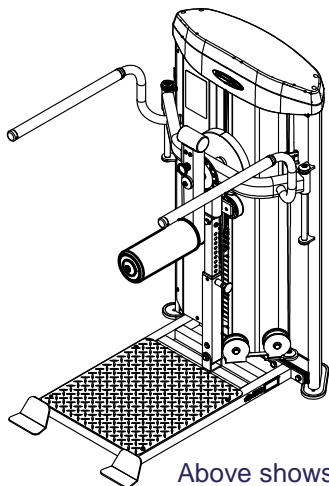

Above shows STEP 10 assembled and completed

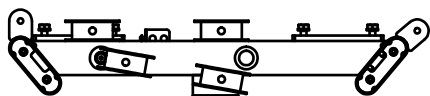
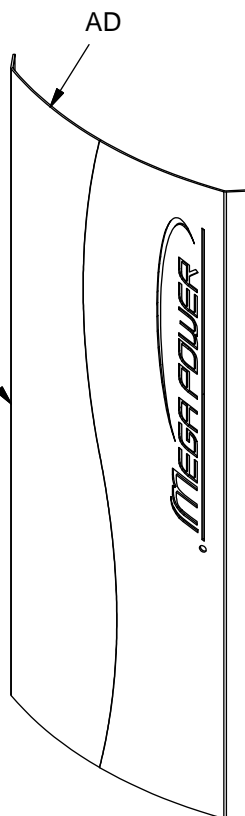
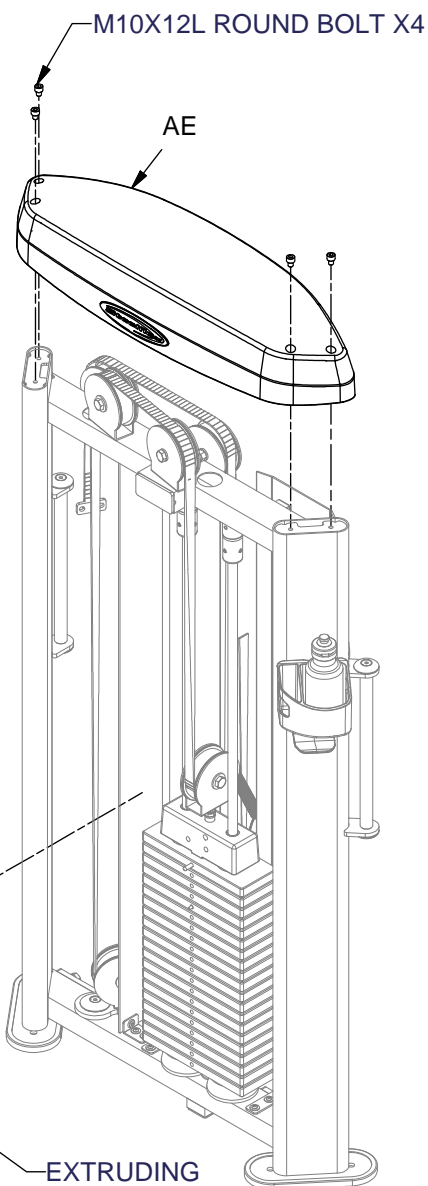
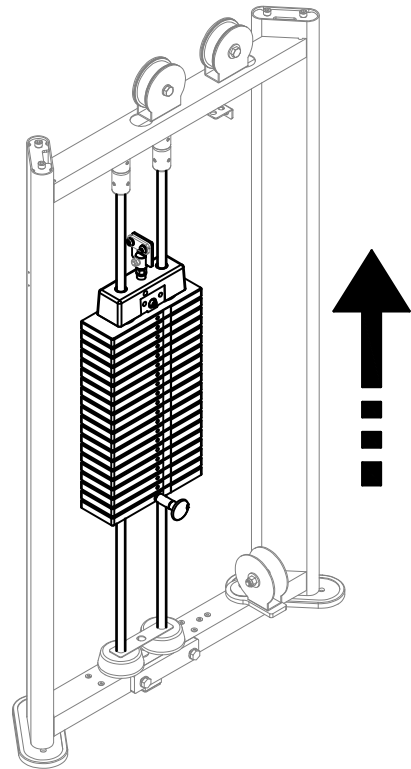
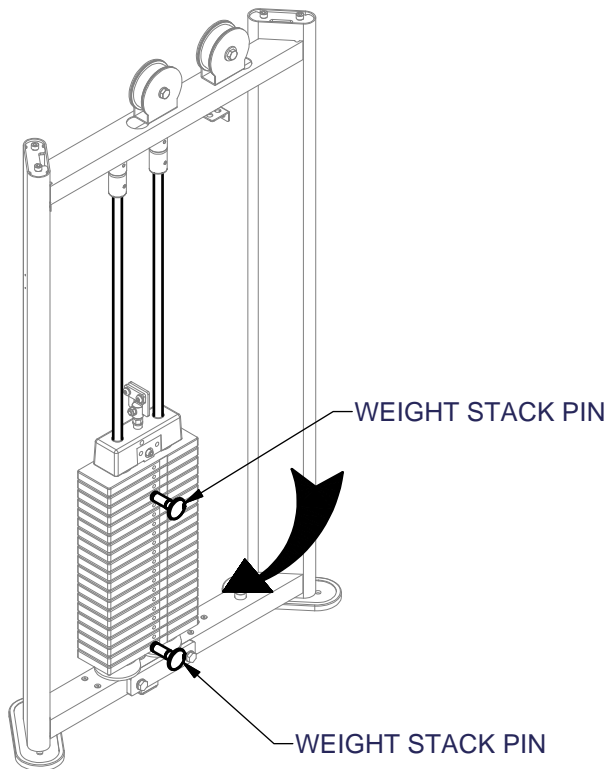

Figure 5

Note: When installing the shroud (AD), push both sides of the shroud toward center in order to bend it a little. After insert it to the door frame and then releasing it. The shroud will be locked on the door frame.

# ASSEMBLY INSTRUCTIONS

## Adjust Flat Belt Steps



1. When installing flat belt, please put the weight stack pin into 4<sup>th</sup> weight stack. After installing flat belt, please put the weight stack pin into 20<sup>th</sup> weight stack.

2. When weight stack pin put into 20<sup>th</sup> weight stack, please do workout with the machine around 1 minute or 5-10 sets in order to extend the flat belt, flat belt will be loosed a little bit.

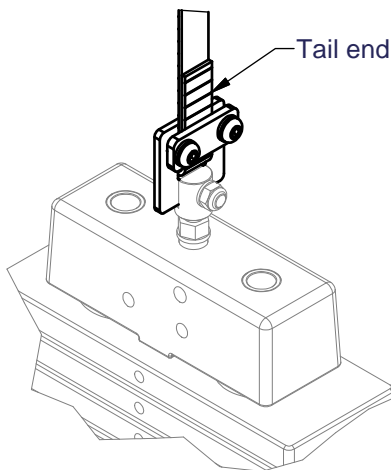

3. Pull end of flat belt as drawing showed to make the flat belt be tightened.  
(After using the machine 3 months to 6 months, please check flat belt. If the flat belt is loosed, please follow this step to tighten the belt again.)

## Guide on Selector Rod Adjustment

### STEP 1

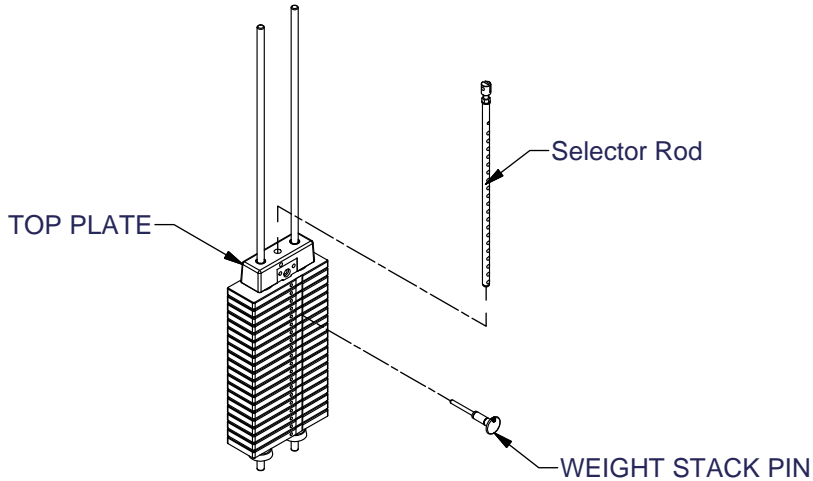

Step 1  
Place Selector Rod into Top Plate.  
Then put selector pin into the weight plate to fix the rod.

### STEP 2

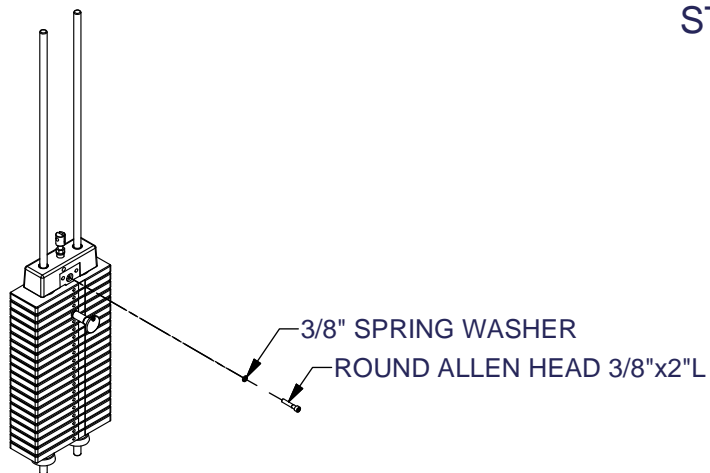

Step 2  
Screw the 3/8"x2"L Round Allen Head  
into Top Plate but not tighten it up.

### STEP 3

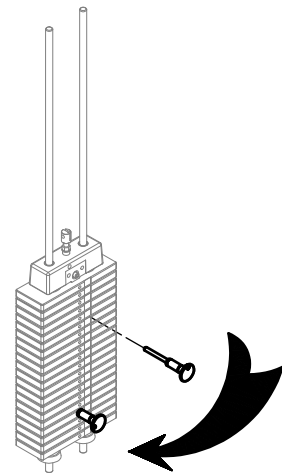

Step 3  
Place the selector pin to each weight plate  
(5,10,15,20...) to check the smoothness.

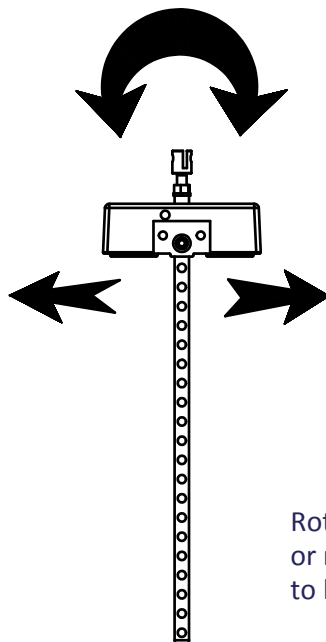

Rotate the Selector Rod slightly  
or move the 3/8"x2"L Round Allen Head  
to left and right and repeat Step 3.

# MEGA POWER series JUNGLE GYM series

project	Part number	Name	Specification	Quantity	Remark
1	38-200 CAP	round allen head	3/8"X2"L round allen head-CAP	1	
2	38-SPWAS 8732003	3/8" spring washer		1	
3	8210-216C	20 hole Selector Rod		1	
4	8250-166	pin	Ø7.9X137L	1	
5	8250-162	weight stack pin	Ø7X110L	1	
6	8400-010	10LB weight stack plate	102x22tx280L 10LB	20	
7	8400-033	top plate		1	

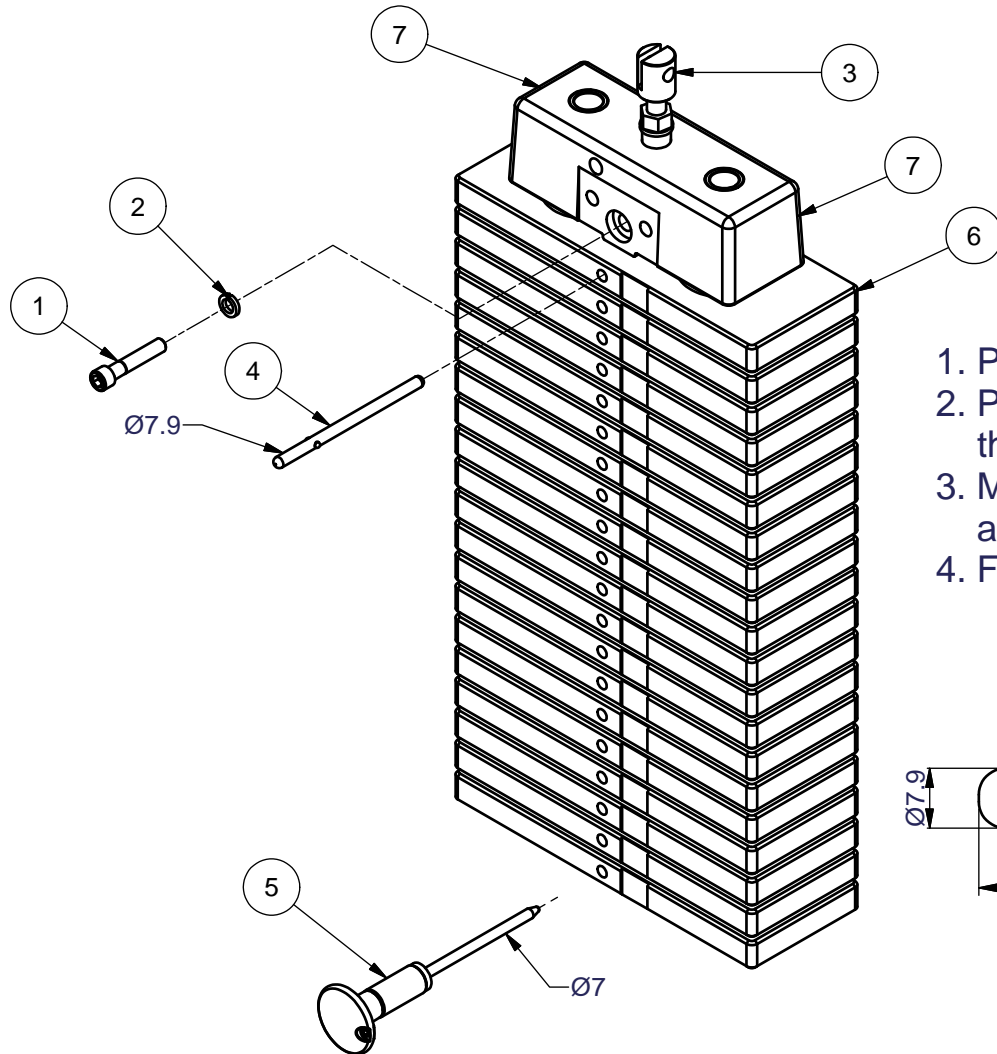

1. Place #4 - 8250-166 (pin) into the first weight plate.
2. Place #5 - 8250-162 (weight stack pin) into the the hole 20th of the weight stack.
3. Make sure #7 (top plate) cling to #6 (first weight plate) and fix in #1 - 3/8"X2"L screw and #2 - 3/8" spring washer.
4. Finally remove #5 - 8250-162 (weight stack pin) and use as usual.

