

**MEGA POWER**

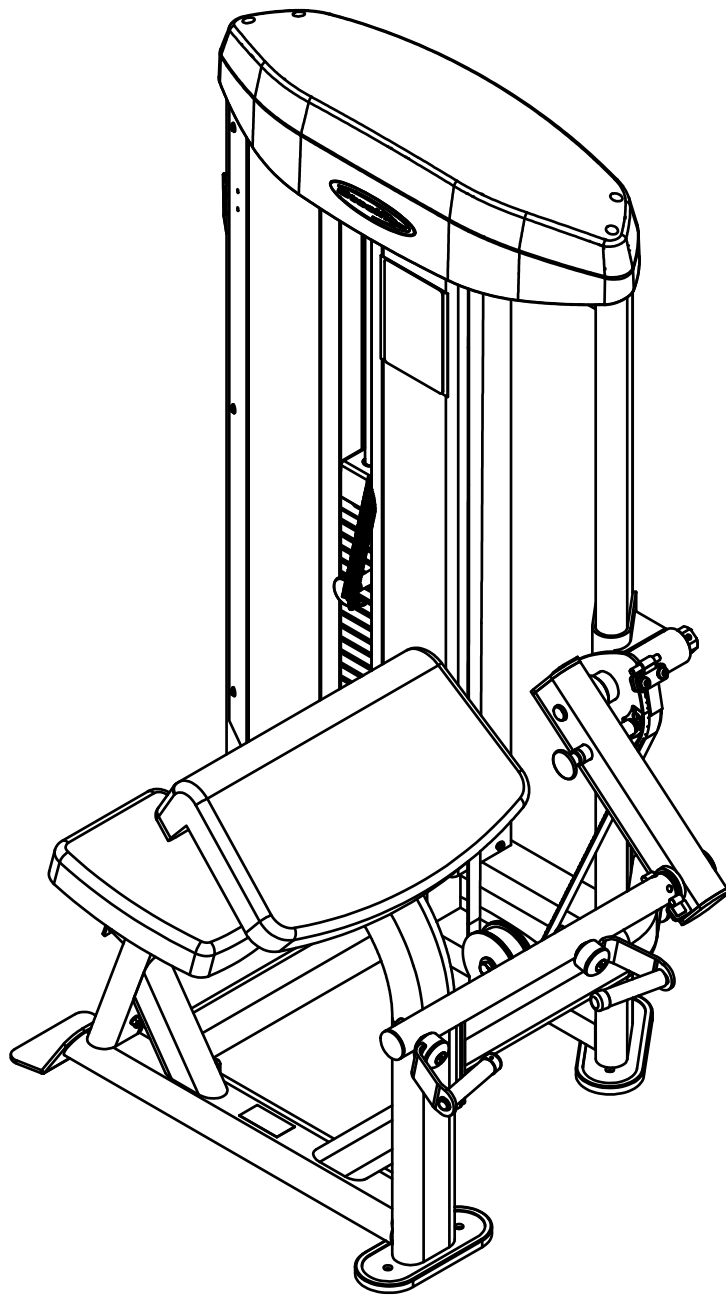

**Steelflex**

JOONG CHENN INDUSTRY CO., LTD.

Sales Office:

3F28, No.5, Shin-Yi Rd., Sec. 5, Taipei, Taiwan 110 R.O.C.

Tel: 886-2-27209980

Fax: 886-2-27229750

[www.steelflexfitness.com](http://www.steelflexfitness.com)

**MBC-600.3 OWNER'S MANUAL**

# MBC600 ASSEMBLY INSTRUCTIONS

## HARDWARE ILLUSTRATION

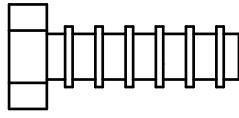
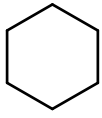

(A1)HEX BOLT 5/16"x1"L PARTIAL THREAD QTY.10

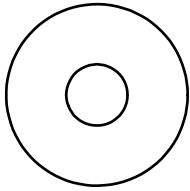

(C1)5/16"(I.D.)FLAT WASHER Ø24 QTY.10

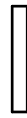
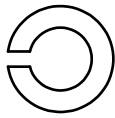

(C2)SPRING WASHER 5/16" QTY.10

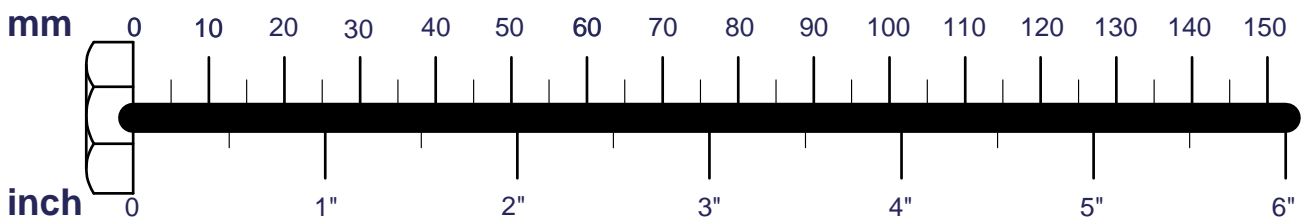

# MBC600 ASSEMBLY INSTRUCTIONS

## FRAME HARDWARE ILLUSTRATION

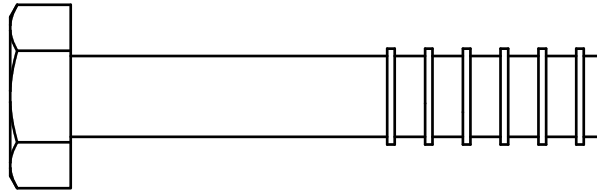
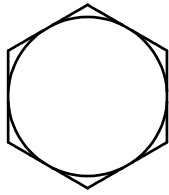

(AA1)HEX BOLT 1/2"x2-3/4"L PARTIAL QTY.3

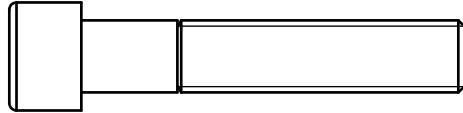
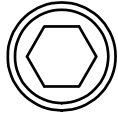

(AA2)ROUND INNER HEAD 3/8"x2"L PARTIAL QTY.1

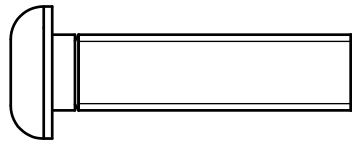
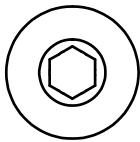

(AA3)ROUND INNER HEX SCREW M10x40L PARTIAL THREAD QTY.1

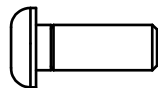

(AA4)ROUND INNER HEX SCREW M6x16L PARTIAL THREAD QTY.16

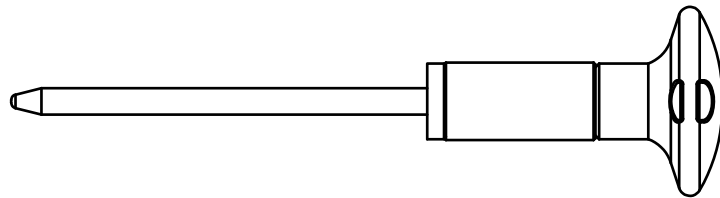

(AA5)10 , 15 , 20LB PIN (8250-162) QTY.1

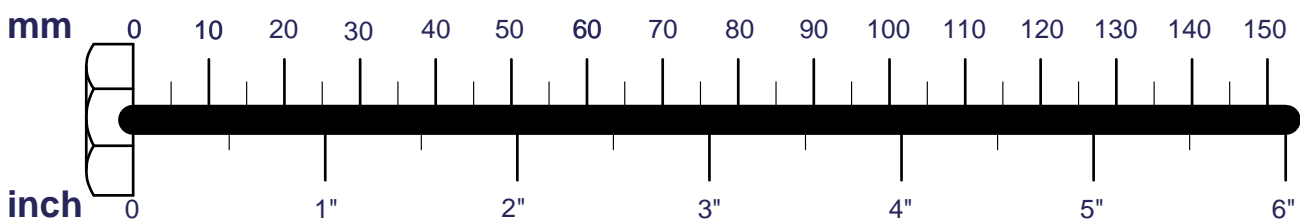

# MBC600 ASSEMBLY INSTRUCTIONS

## FRAME HARDWARE ILLUSTRATION

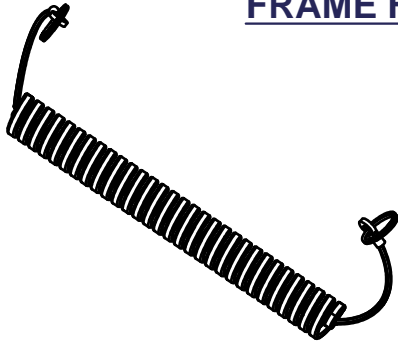

(AA6)ELASTIC BELT (F920003) QTY.1

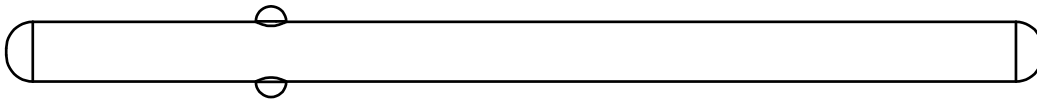

(AA7)Ø5/16" FIXED PIN (8250-166) QTY.1

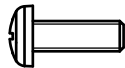

(AA8)ROUND HEAD PHILLIPS M4X12L PARTIAL THREAD QTY.2

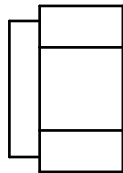
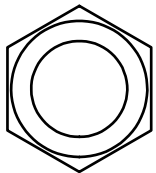

(BB1)NYLON LOCK NUT 1/2" QTY.3

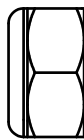
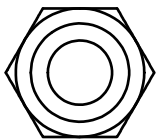

(BB2)NYLON LOCK NUT M10 QTY.1

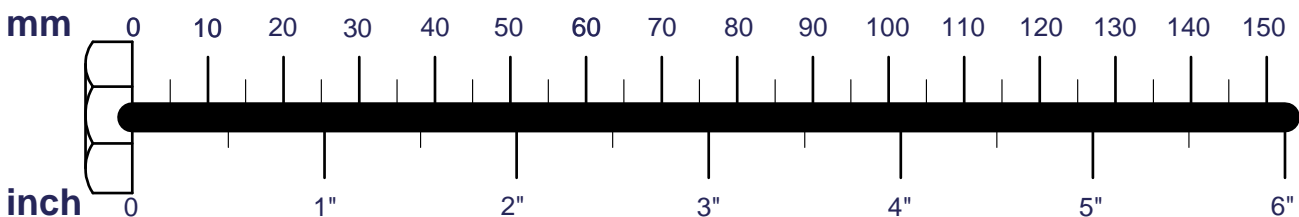

# MBC600 ASSEMBLY INSTRUCTIONS

## FRAME HARDWARE ILLUSTRATION

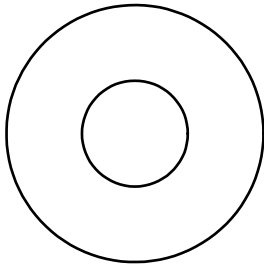

(CC1) 1/2" (I.D.) FLAT WASHER Ø34 QTY.4

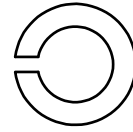

(CC5) SPRING WASHER 3/8" QTY.1

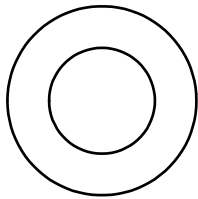

(CC2) 1/2" (I.D.) FLAT WASHER Ø25 QTY.2

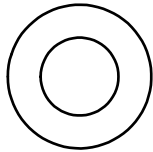
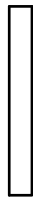

(CC3) M10 (I.D.) FLAT WASHER Ø19 QTY.2

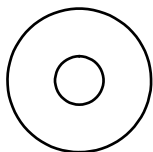

(CC4) M6 (I.D.) FLAT WASHER Ø19 QTY.16

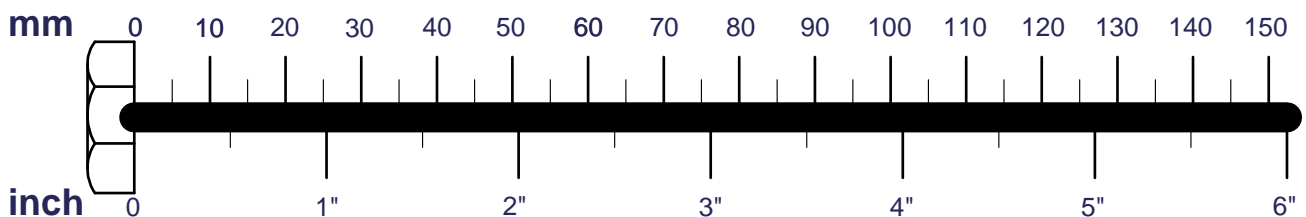

# MBC600 ASSEMBLY INSTRUCTIONS

## FARME HARDWARE ILLUSTRATION

DD1.Ø3/4" SHAFT COLLAR(9211-147)-----	[2PCS]
DD2.Ø4" RUBBER DOUNT(9310-017)-----	[2PCS]
DD3.108X14.5tX263L RUBBER PAD(9310-075)-----	[2PCS]
DD4.Ø115X50L PULLEY-NO MAGNET(9213-042B)-----	[3PCS]
DD6.BOTTLE BRACKET(8388-025)-----	[1PCS]
DD7.BOTTLE RACK(9260-320)-----	[1PCS]
DD8.BOTTLE(9260-123)-----	[1PCS]
DD11.TOP PLATE(8400-033)-----	[1PCS]
DD12.Ø3/4" SHAFT COLLAR(9211-167)-----	[2PCS]
DD13.WEIGHT SELECTOR BAR(8210-216C)-----	[1PCS]

DD1.

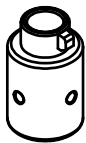

DD2.

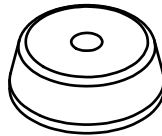

DD3.

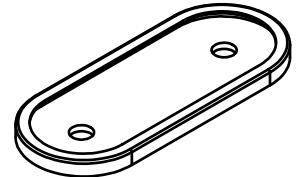

DD4.

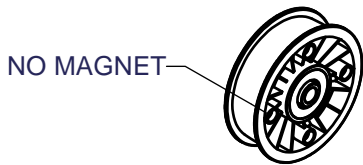

DD6.



DD7.

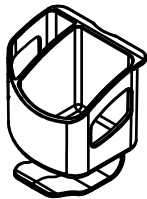

DD8.



DD11.

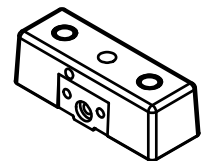

DD12.



DD13.

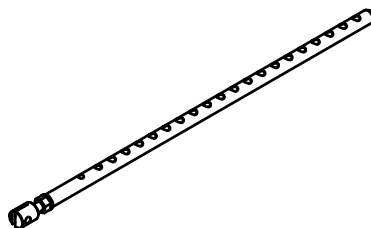

# MBC600 ASSEMBLY INSTRUCTIONS

## HARDWARE ILLUSTRATION

D1.Ø60 CAP COVER(8130-231)-----	[1PCS]
D2.Ø10X60L SHAFT(8210-156)-----	[1PCS]
D3.THRUST BEARING(8510-008)-----	[1PCS]
D4.Ø38X26X1.5t CU WASHER(8520-008)-----	[2PCS]
D5.Ø50 END CAP(9211-020)-----	[1PCS]
D6.108X15tX263L RUBBER PAD(9310-075)-----	[1PCS]
D7.3590mm BELT (FMBC6001)-----	[1PCS]
D8.Ø50XØ26X3t NYLON WASHER(9214-001)-----	[1PCS]

D1.

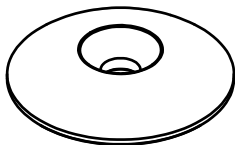

D2.

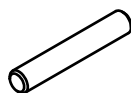

D3.

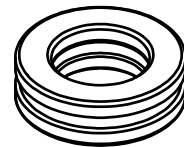

D4.



D5.

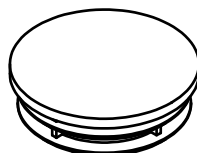

D6.

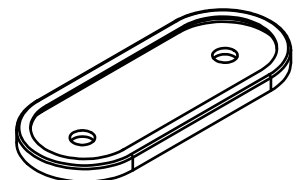

D7.

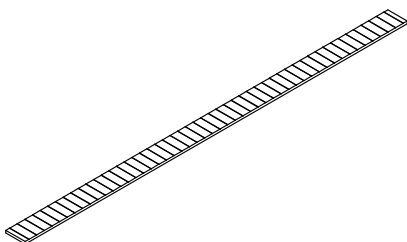

D8.



# MBC600 ASSEMBLY INSTRUCTIONS

## PARTS ILLUSTRATION SHEET

A [1SET]  
6621-003

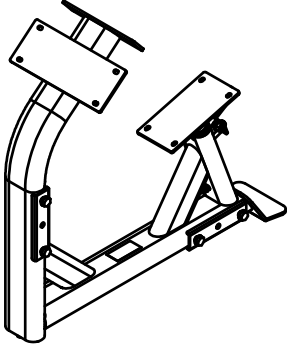

B [1SET]  
6630-005

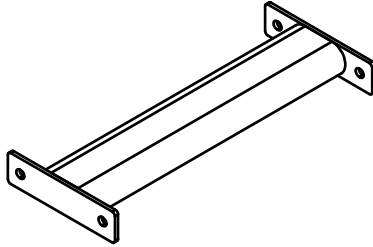

C [1SET]  
6630-004

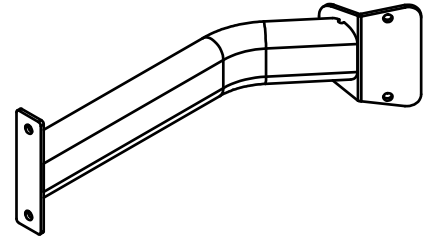

D [1SET]  
6680-017

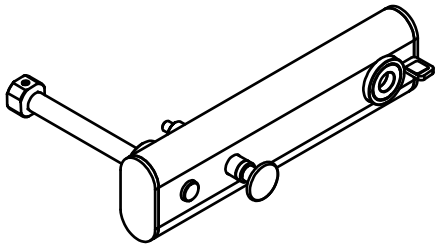

E [1SET]  
6680-016

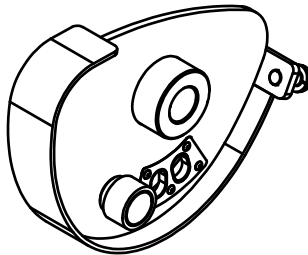

F [1SET]

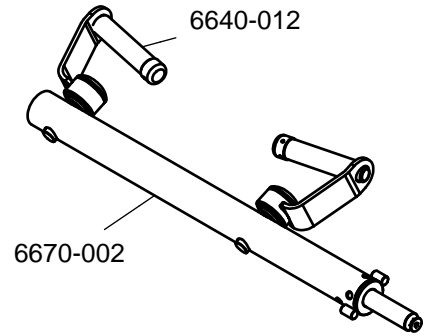

G [1PCS]  
8313-144

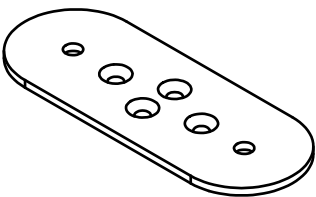

H [1PCS]  
8311-117

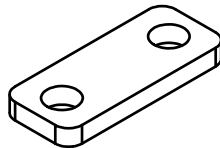

I [1PCS]  
9420-102

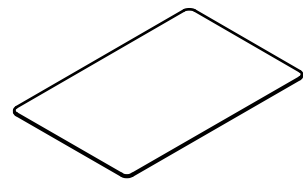

J [1PCS]  
9121-084

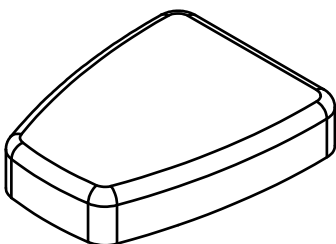

K [1PCS]  
9131-039

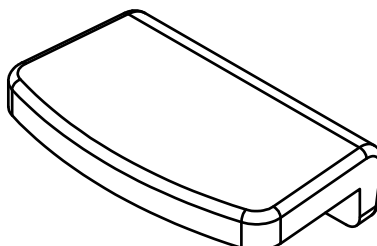



# MBC600 ASSEMBLY INSTRUCTIONS

## FARME PARTS ILLUSTRATION SHEET

AA1 [1SET]  
6610-015

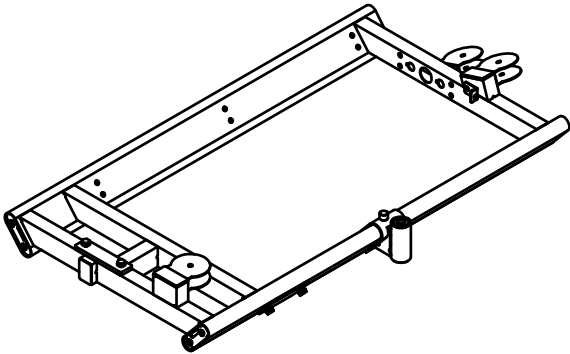

AC1 [1PCS]  
9220-020

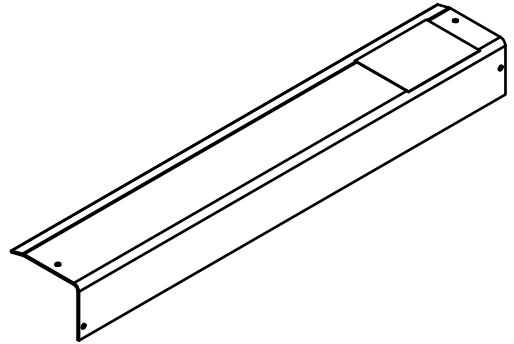

AD [1PCS]  
9220-019

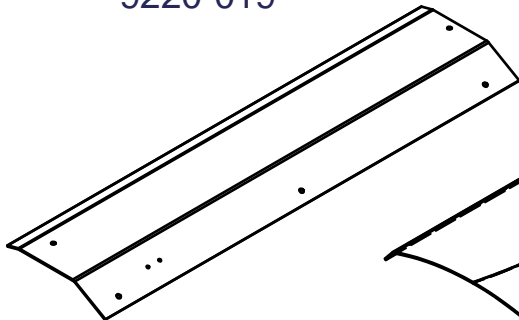

AE [1SET]  
9220-023

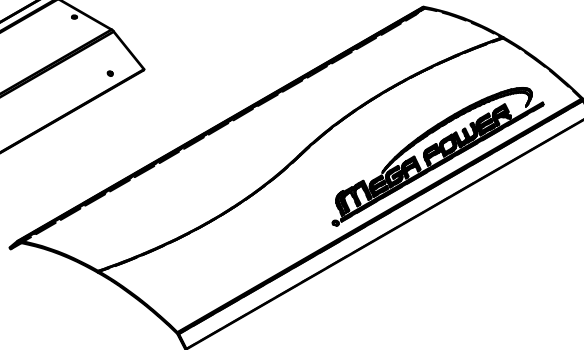

AF [1SET]  
9211-148

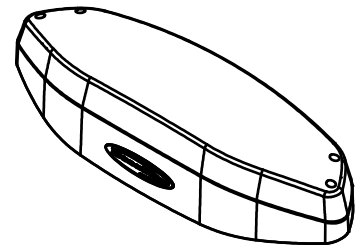

AG [4SET]  
8331-057

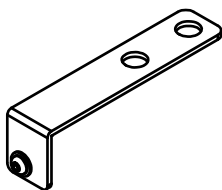

AH [1SET]  
8313-169

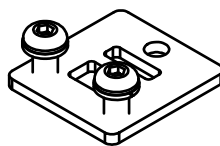

AJ1 [2PCS]  
8280-041  
Ø3/4"X1243L



AK [1PCS]  
8331-056

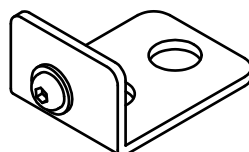

AL [3SET]  
8331-058

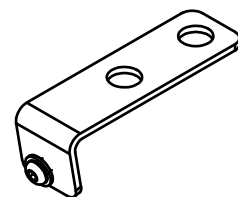

## FARME PARTS ILLUSTRATION SHEET

AM [2PCS]  
8313-144

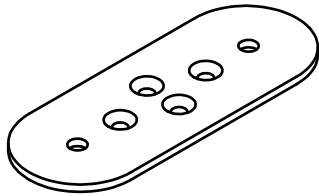

AP [1PCS]  
8311-117

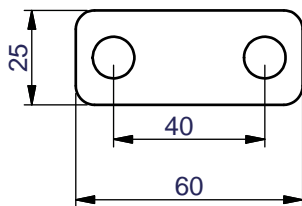
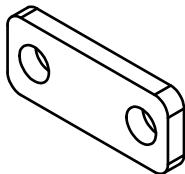

AR [1PCS]  
8311-194

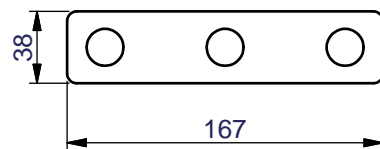
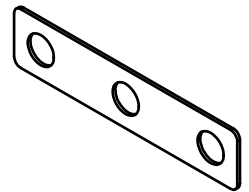

# MBC600 ASSEMBLY INSTRUCTIONS

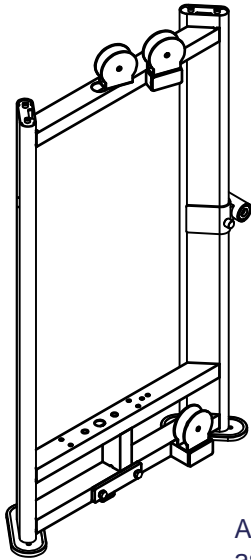

Above shows STEP 1  
assembled and completed

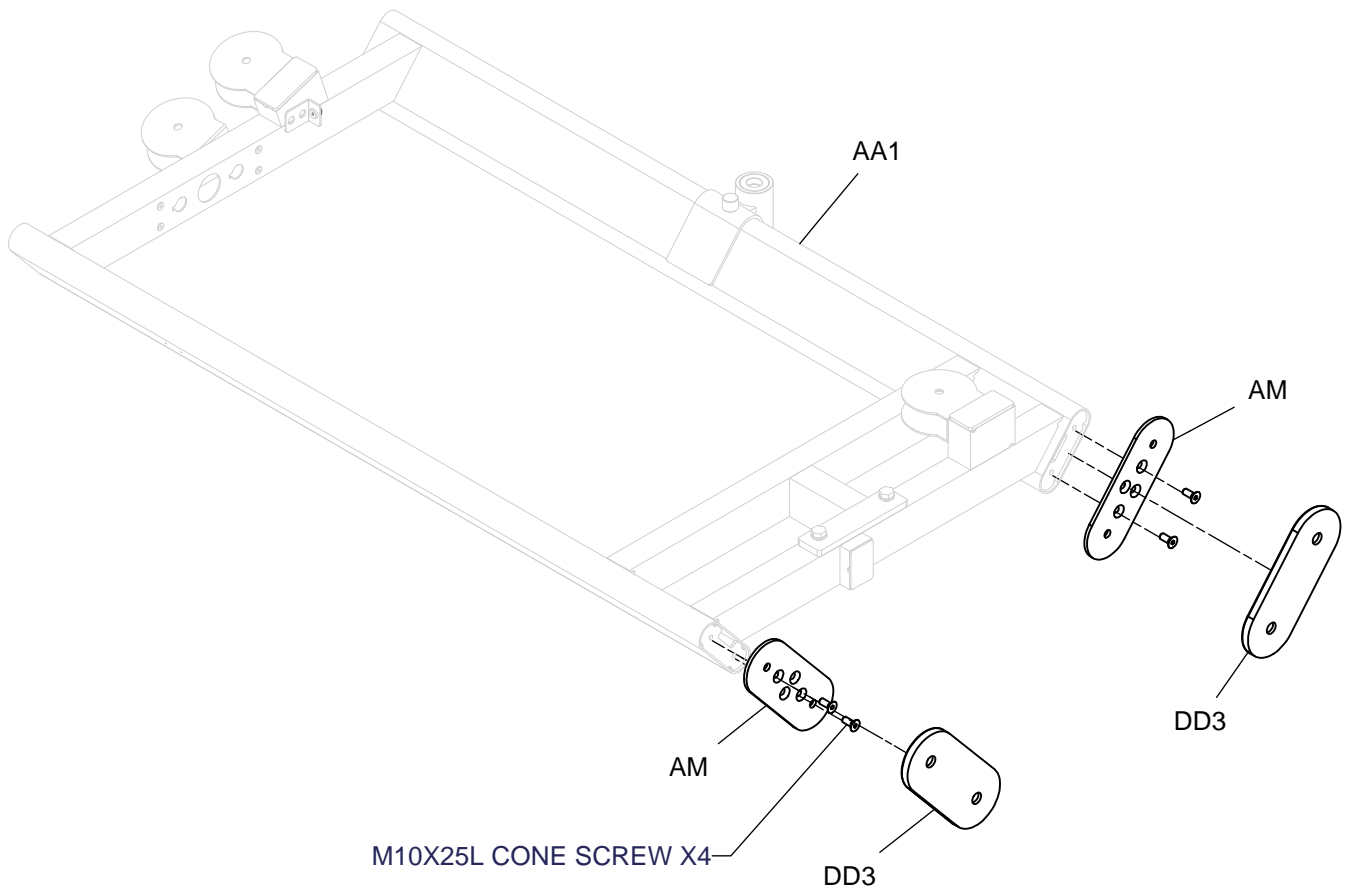

# MBC600 ASSEMBLY INSTRUCTIONS

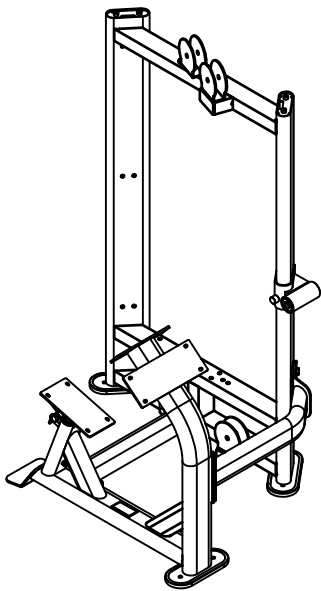

Above shows STEP 2  
assembled and completed

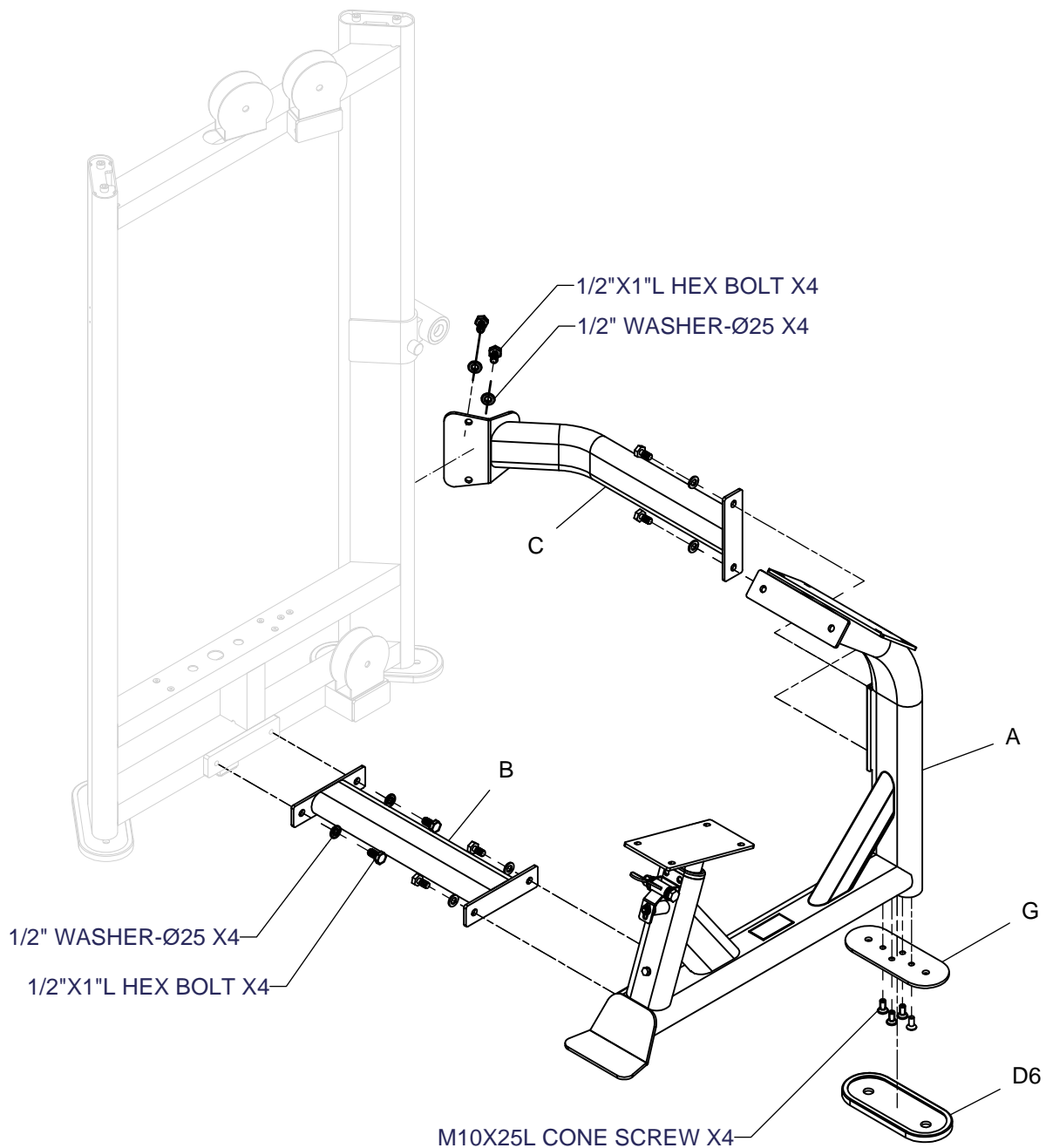

# MBC600 ASSEMBLY INSTRUCTIONS

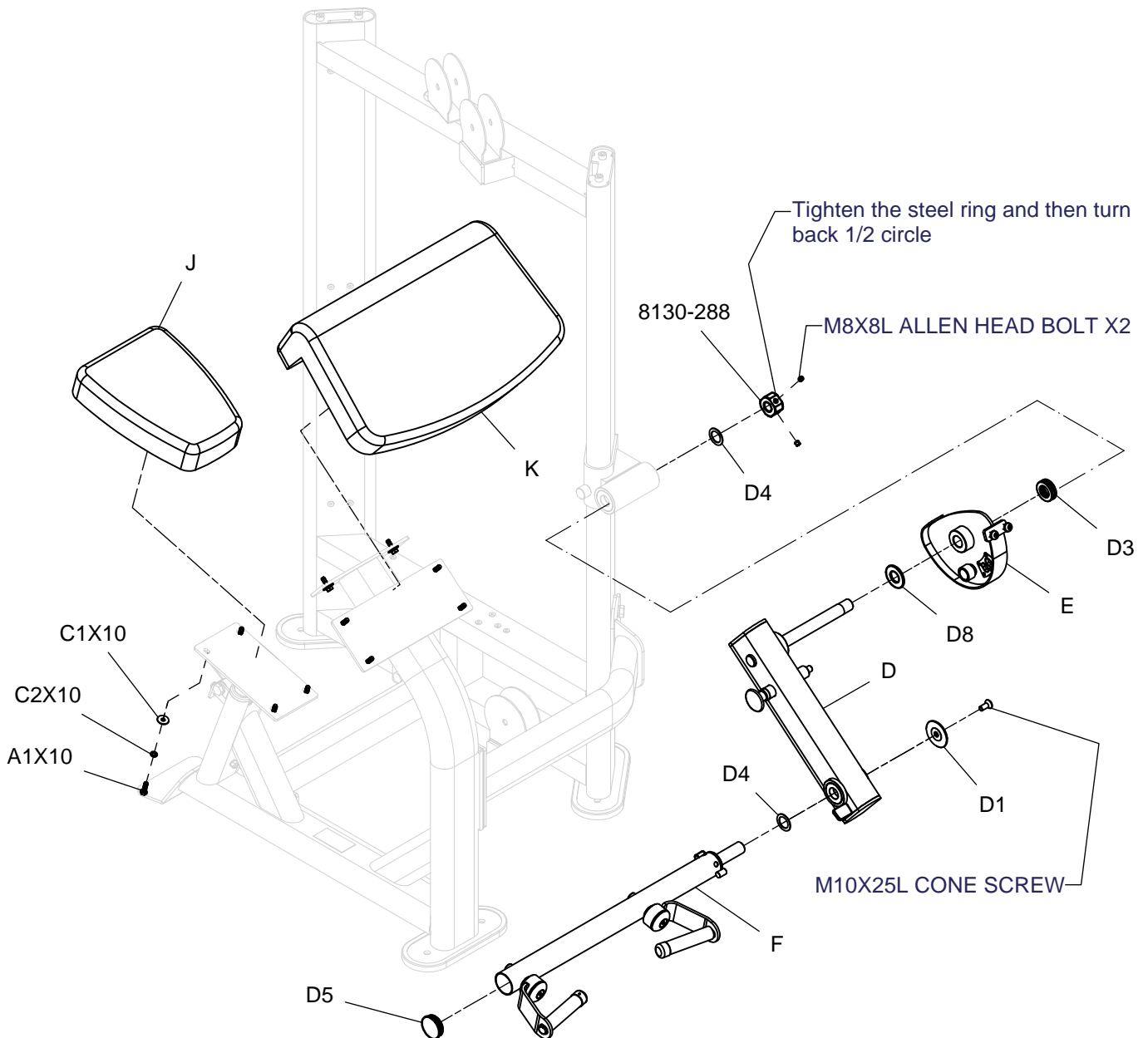
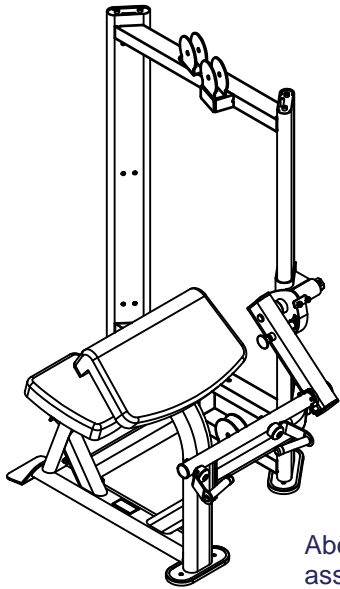

# MBC600 ASSEMBLY INSTRUCTIONS

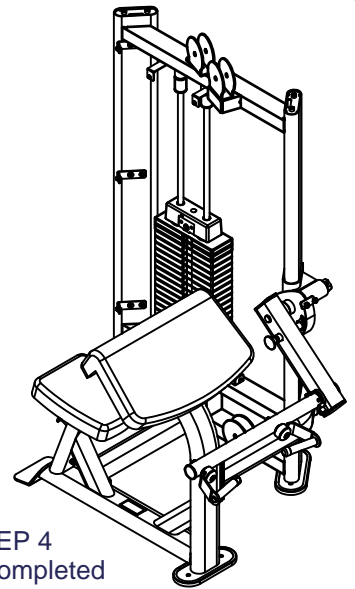

Above shows STEP 4 assembled and completed

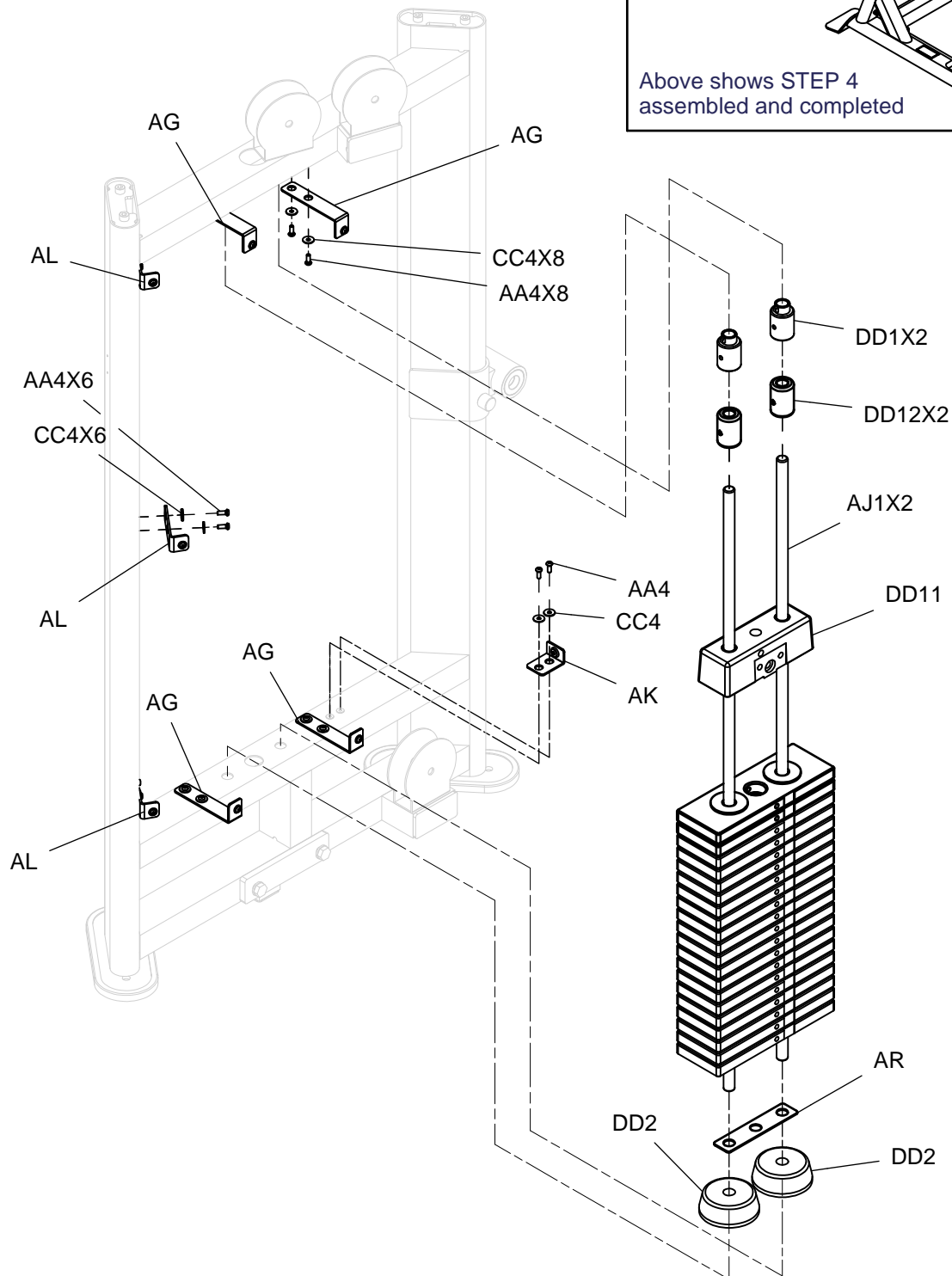

# MBC600 ASSEMBLY INSTRUCTIONS

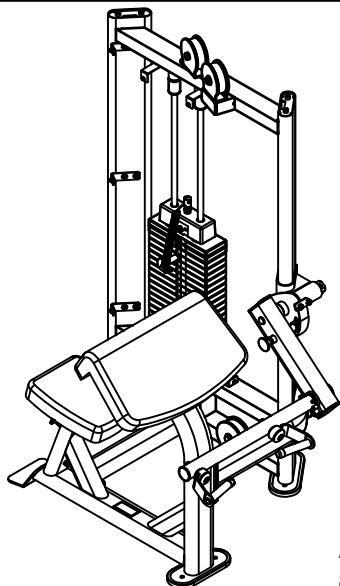

Above shows STEP 5  
assembled and completed

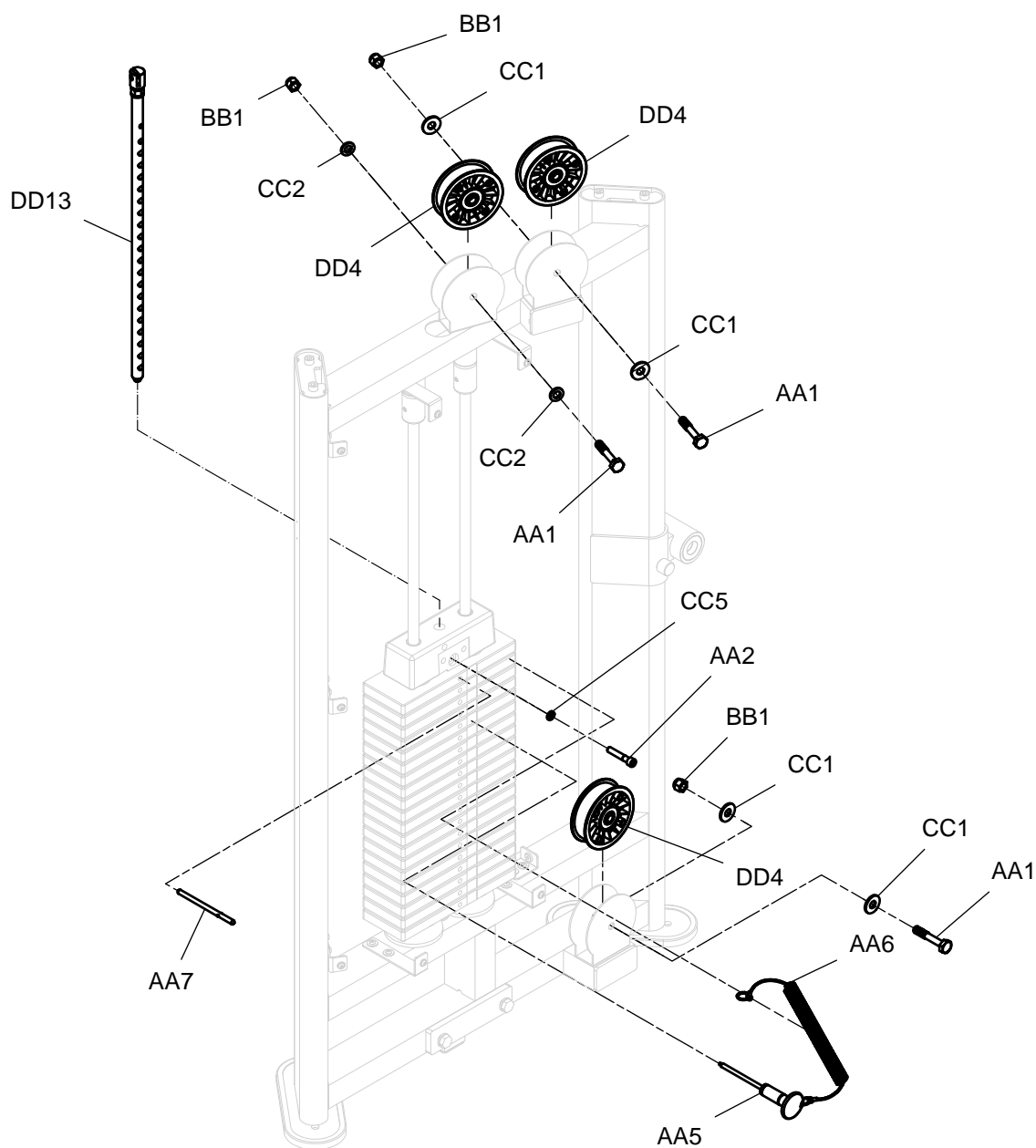

# MBC600 ASSEMBLY INSTRUCTIONS

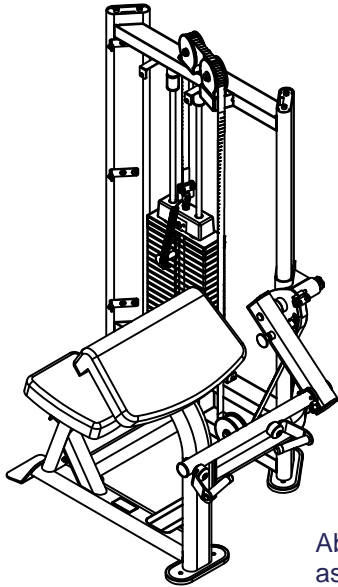

Above shows STEP 6 assembled and completed

The tread side should be outward

M10X25L ROUND BOLT X2

M10 SPRING WASHER X2

M10X25L ROUND BOLT X2

M10 SPRING WASHER X2

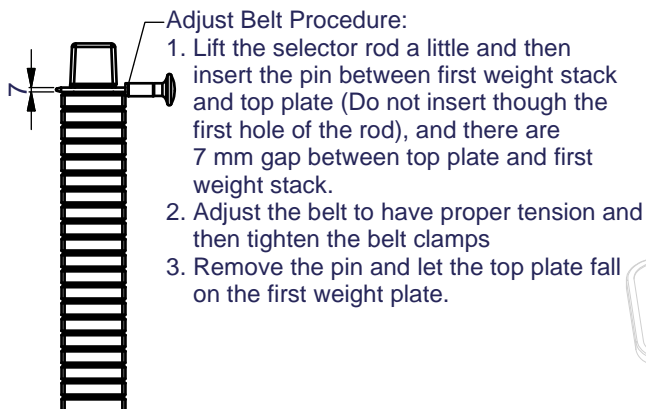
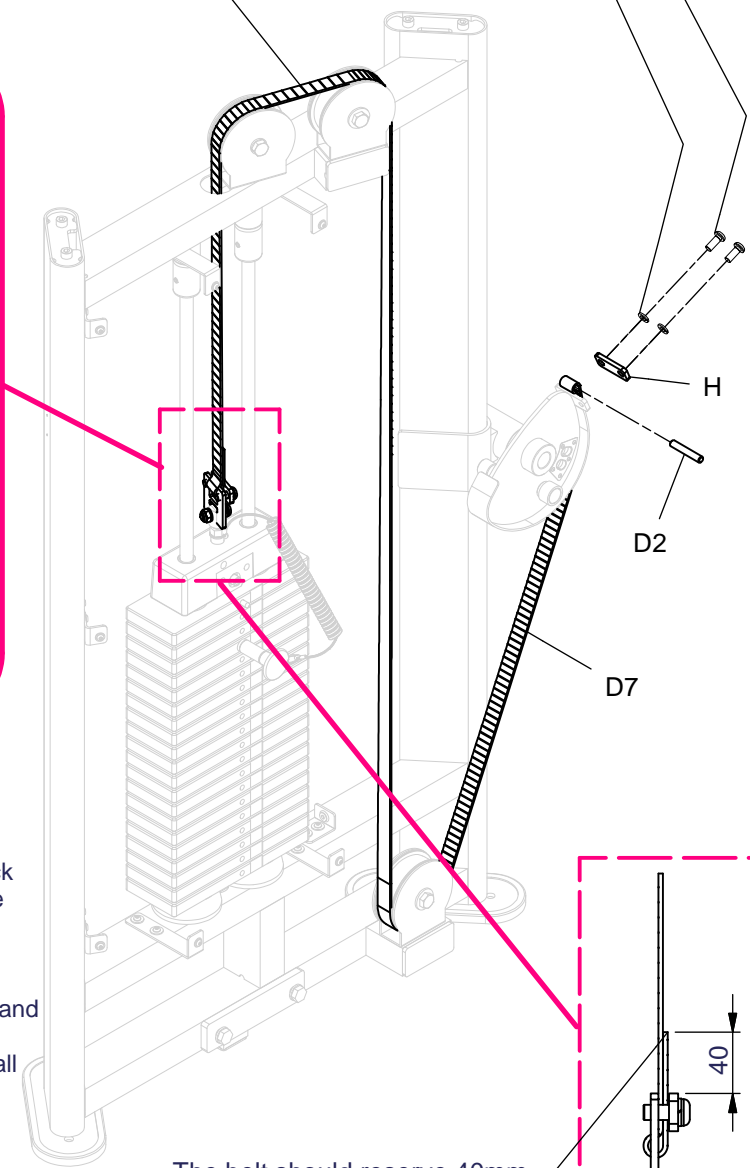
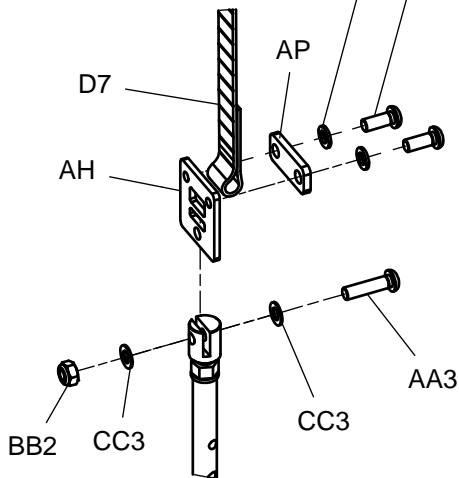

Adjust Belt Procedure:

1. Lift the selector rod a little and then insert the pin between first weight stack and top plate (Do not insert through the first hole of the rod), and there are 7 mm gap between top plate and first weight stack.
2. Adjust the belt to have proper tension and then tighten the belt clamps
3. Remove the pin and let the top plate fall on the first weight plate.

The belt should reserve 40mm extra length

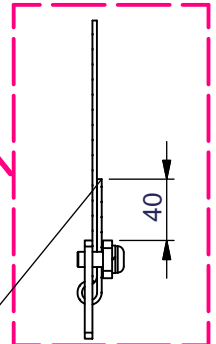



# MBC600 ASSEMBLY INSTRUCTIONS

Post location

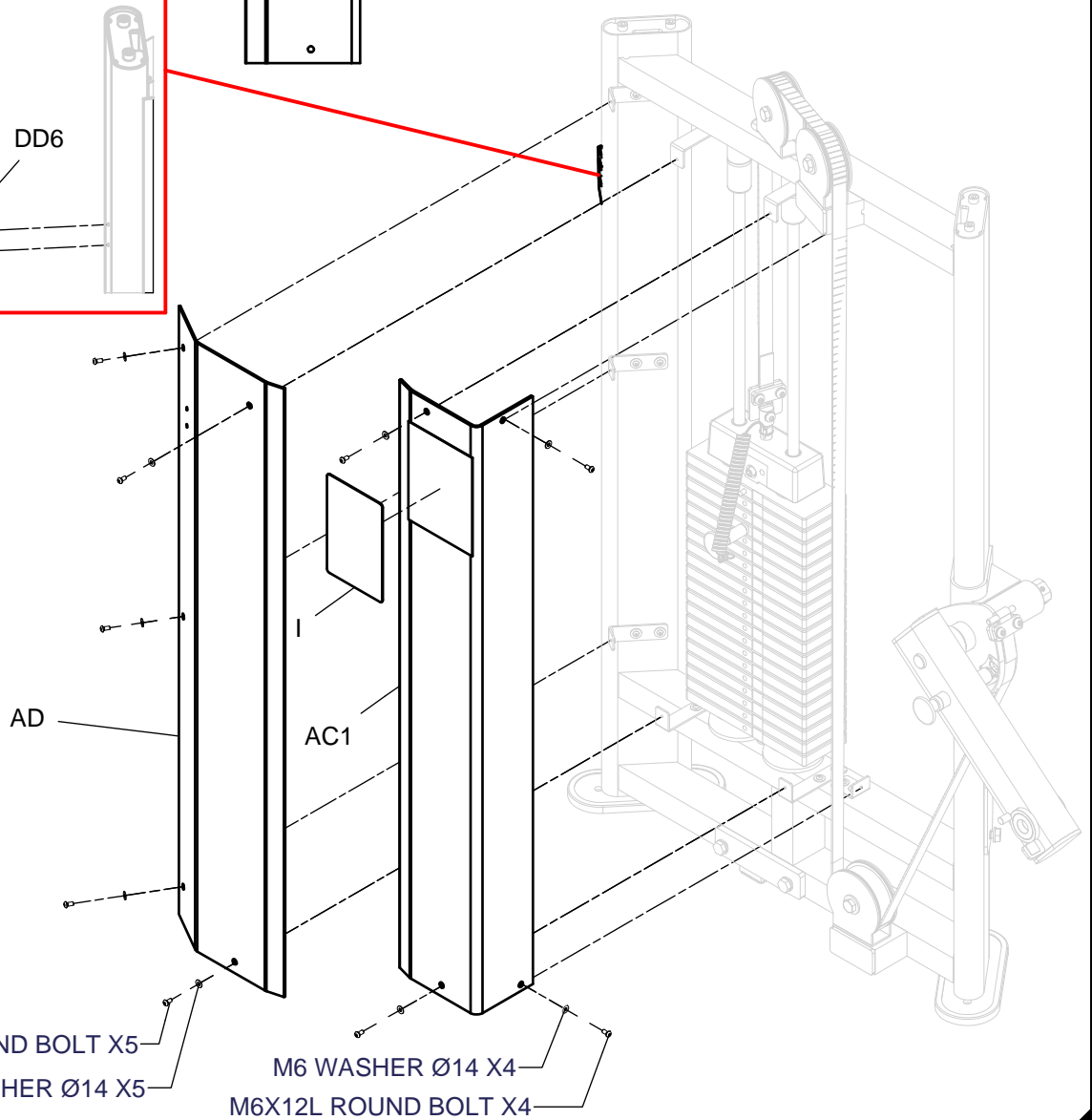
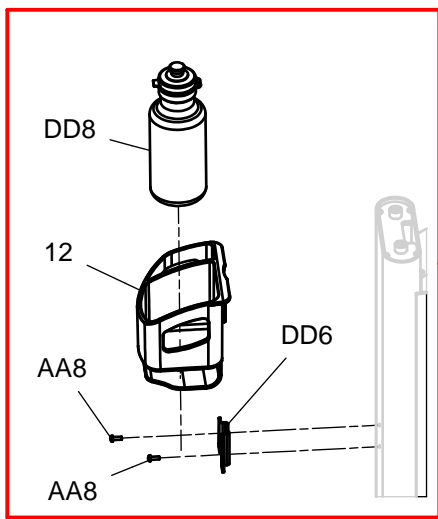
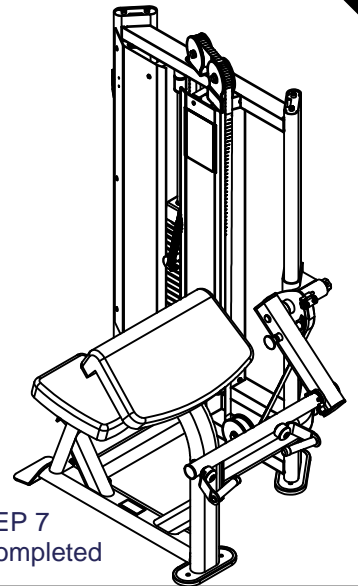
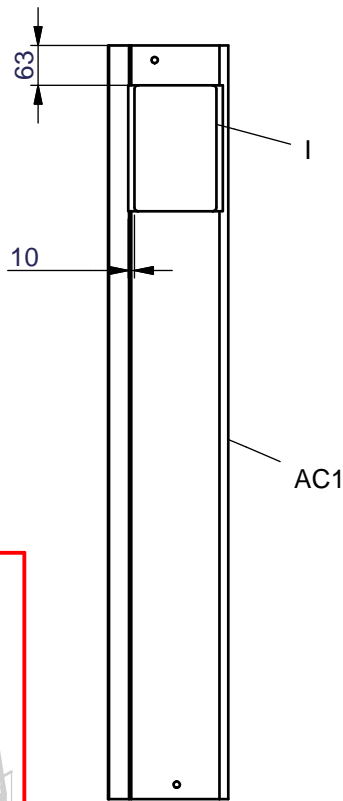

# MBC600 ASSEMBLY INSTRUCTIONS

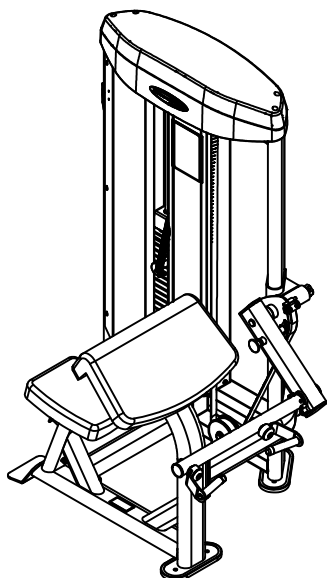

Above shows STEP 8 assembled and completed

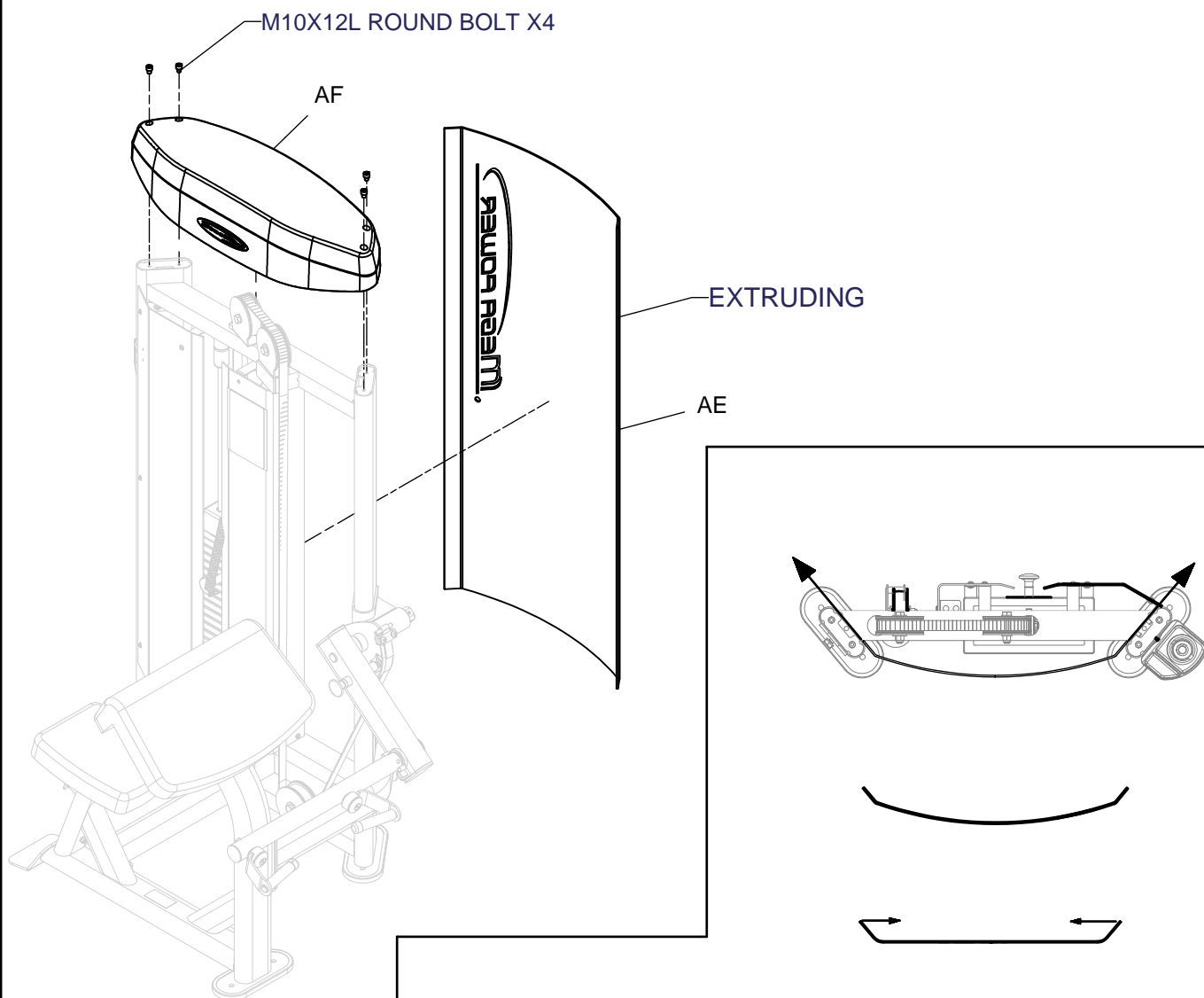

Note: When installing the shroud (AE), push both sides of the shroud toward center in order to bend it a little.  
After insert it to the door frame and then releasing it. The shroud will be locked on the door frame.

# ASSEMBLY INSTRUCTIONS

## Adjust Flat Belt Steps

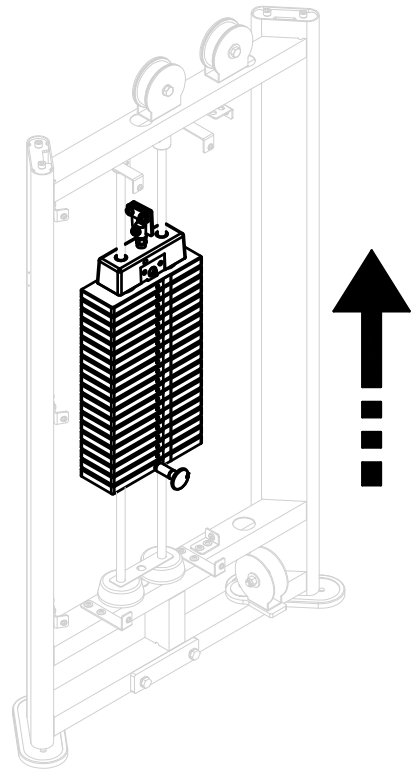
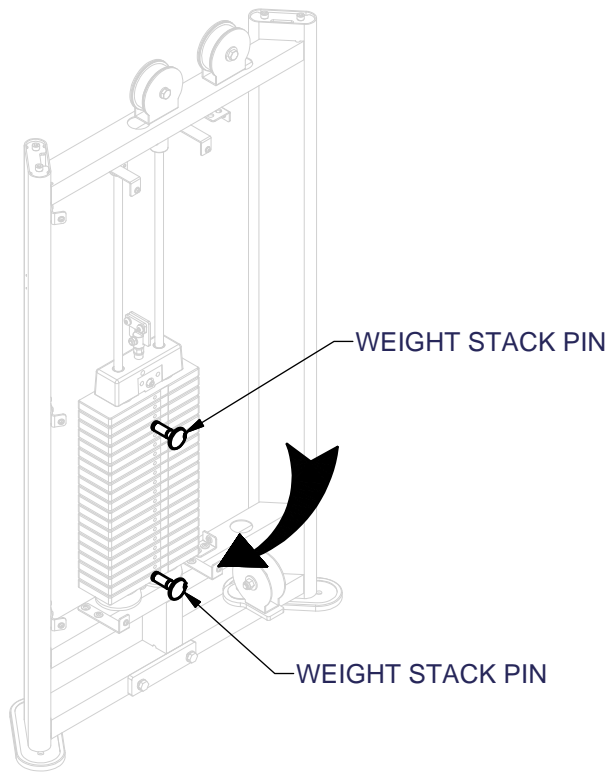

1. When installing flat belt, please put the weight stack pin into 4<sup>th</sup> weight stack. After installing flat belt, please put the weight stack pin into 20<sup>th</sup> weight stack.

2. When weight stack pin put into 20<sup>th</sup> weight stack, please do workout with the machine around 1 minute or 5-10 sets in order to extend the flat belt, flat belt will be loosed a little bit.

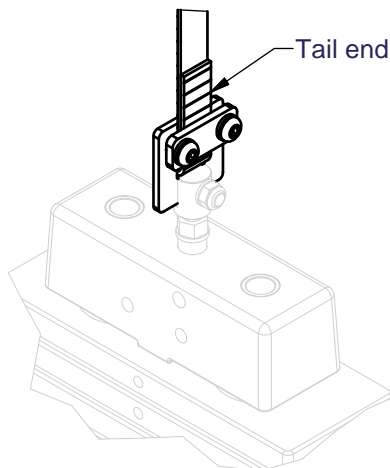

3. Pull end of flat belt as drawing showed to make the flat belt be tightened.  
(After using the machine 3 months to 6 months, please check flat belt. If the flat belt is loosed, please follow this step to tighten the belt again.)

## Guide on Selector Rod Adjustment

### STEP 1

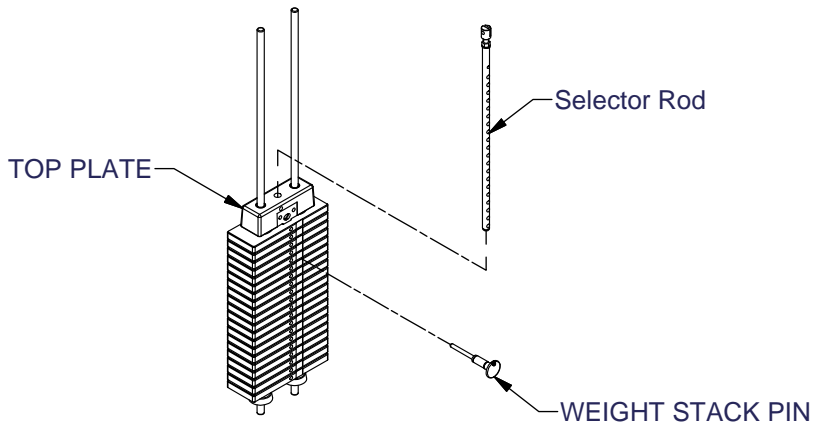

Step 1  
Place Selector Rod into Top Plate.  
Then put selector pin into the weight plate to fix the rod.

### STEP 2

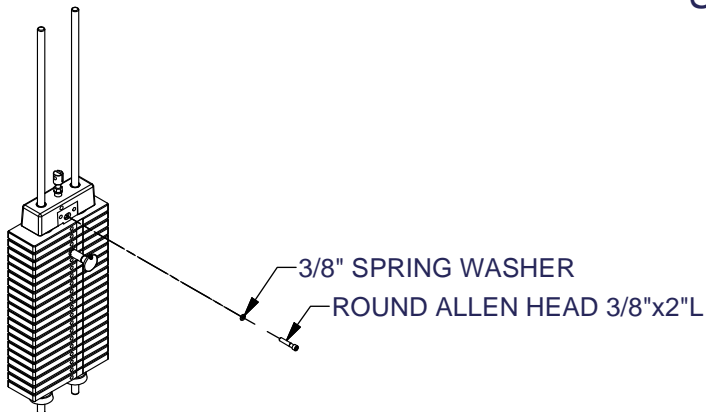

Step 2  
Screw the 3/8"x2"L Round Allen Head  
into Top Plate but not tighten it up.

### STEP 3

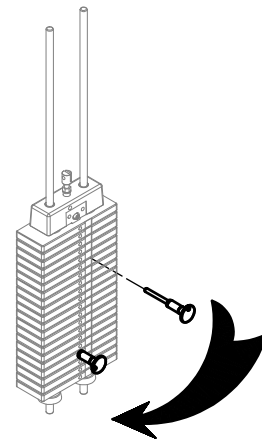

Step 3  
Place the selector pin to each weight plate  
(5,10,15,20...) to check the smoothness.

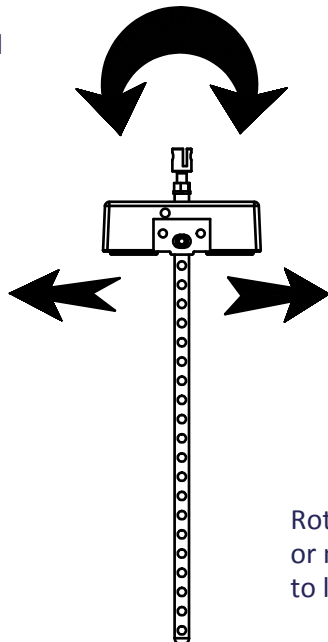

Rotate the Selector Rod slightly  
or move the 3/8"x2"L Round Allen Head  
to left and right and repeat Step 3.

# MEGA POWER series JUNGLE GYM series

project	Part number	Name	Specification	Quantity	Remark
1	38-200 CAP	round allen head	3/8"X2"L round allen head-CAP	1	
2	38-SPWAS 8732003	3/8" spring washer		1	
3	8210-216C	20 hole Selector Rod		1	
4	8250-166	pin	Ø7.9X137L	1	
5	8250-162	weight stack pin	Ø7X110L	1	
6	8400-010	10LB weight stack plate	102x22tx280L 10LB	20	
7	8400-033	top plate		1	

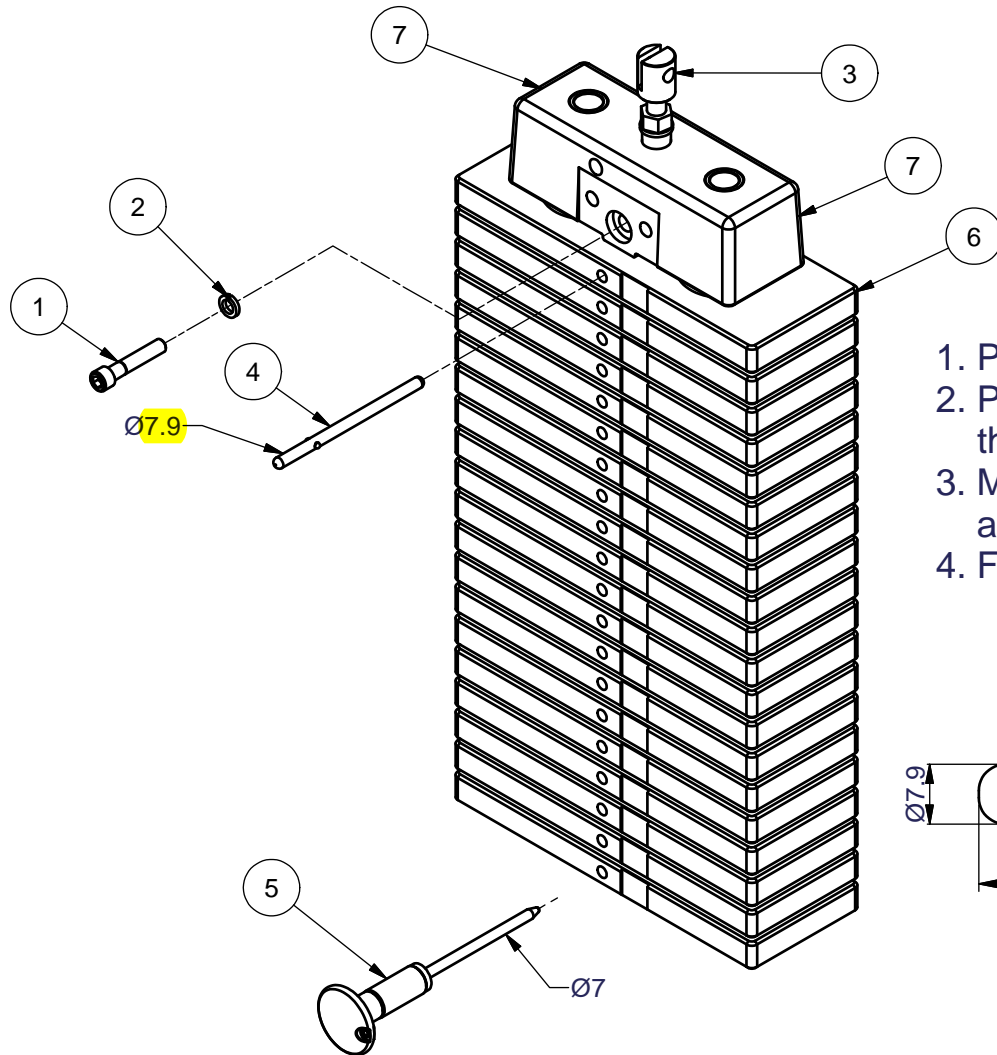

1. Place #4 - 8250-166 (pin) into the first weight plate.
2. Place #5 - 8250-162 (weight stack pin) into the the hole 20th of the weight stack.
3. Make sure #7 (top plate) cling to #6 (first weight plate) and fix in #1 - 3/8"X2"L screw and #2 - 3/8" spring washer.
4. Finally remove #5 - 8250-162 (weight stack pin) and use as usual.

