

**MEGA POWER**

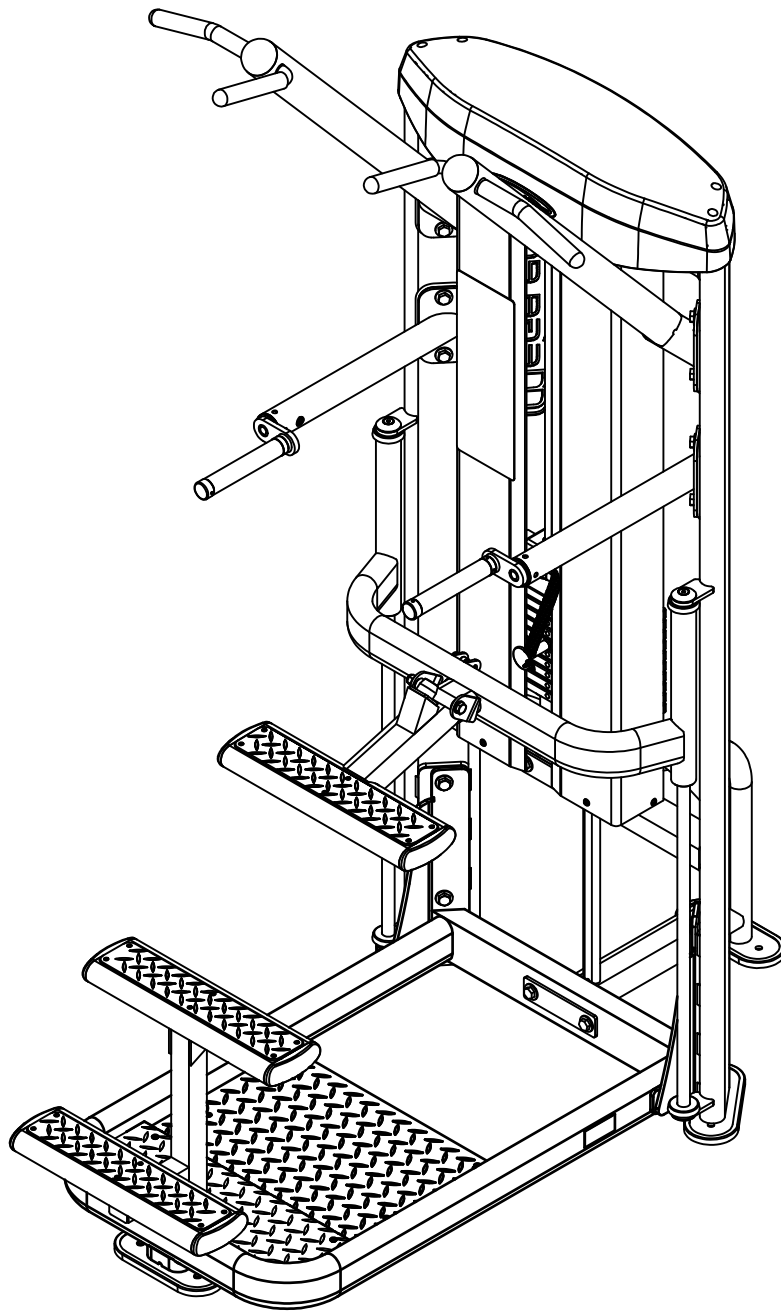

**Steelflex**

JOONG CHENN INDUSTRY CO., LTD.

Sales Office:

3F28, No.5, Shin-Yi Rd., Sec. 5, Taipei, Taiwan 110 R.O.C.

Tel: 886-2-27209980

Fax: 886-2-27229750

[www.steelflexfitness.com](http://www.steelflexfitness.com)

**MCD2100.3 OWNER'S MANUAL**

# MCD2100 ASSEMBLY INSTRUCTIONS

## HARDWARE ILLUSTRATION

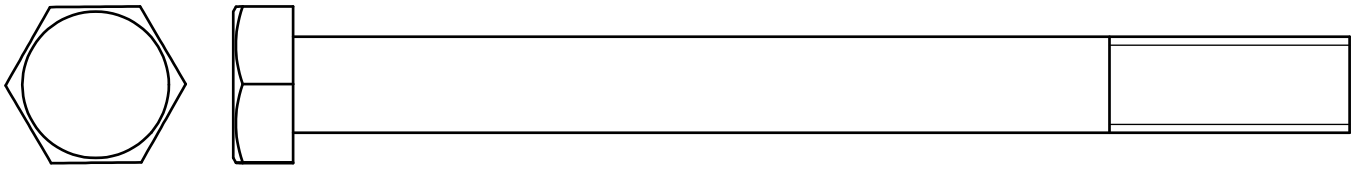

(A1)HEX BOLT 1/2"x5-1/2"L PARTIAL QTY.1

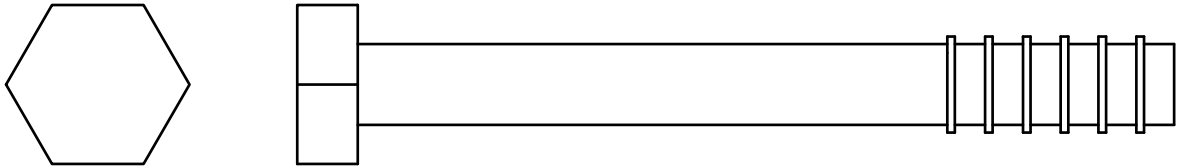

(A2)HEX BOLT 1/2"x4-1/4"L PARTIAL QTY.2

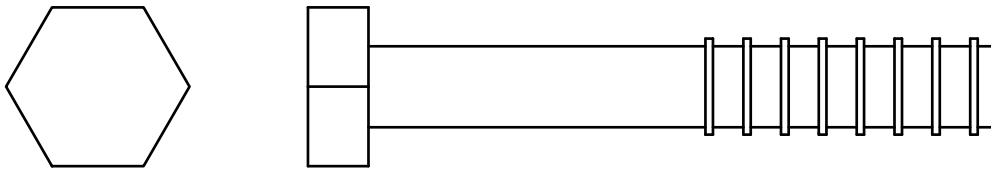

(A3)HEX BOLT 1/2"x3-1/4"L PARTIAL THREAD QTY.6

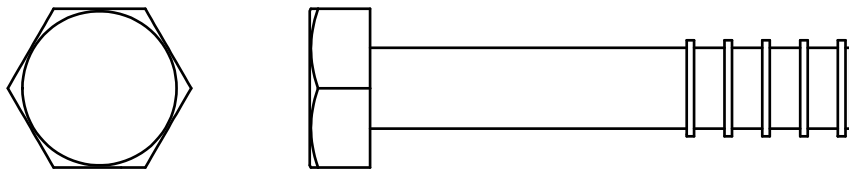

(A4)HEX BOLT 1/2"x2-1/2"L PARTIAL THREAD QTY.1

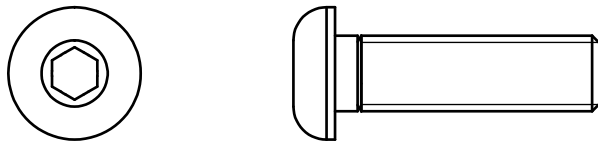

(A5)ROUND INNER HEX SCREW M10x35L PARTIAL THREAD QTY.1

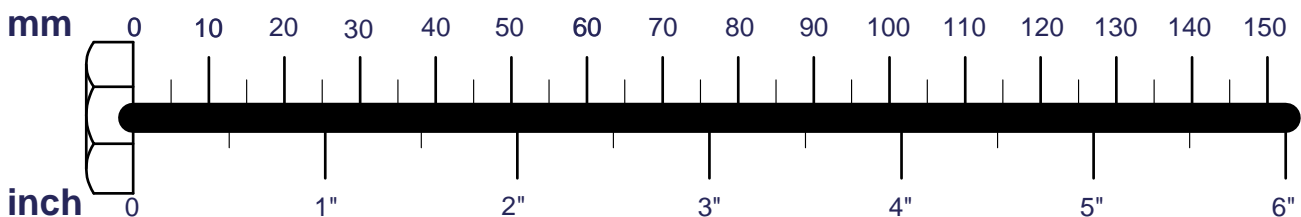

# MCD2100 ASSEMBLY INSTRUCTIONS

## HARDWARE ILLUSTRATION

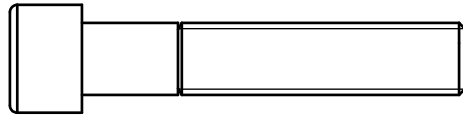
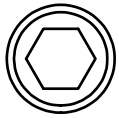

(A6)ROUND INNER HEAD 3/8"x2"L PARTIAL QTY.1

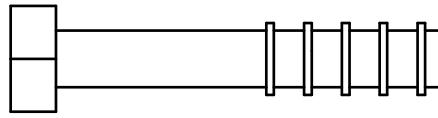
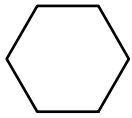

(A7)HEX BOLT 3/8"x2"L PARTIAL THREAD QTY.1

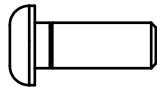

(A8)ROUND INNER HEX SCREW M6x16L PARTIAL THREAD QTY.12

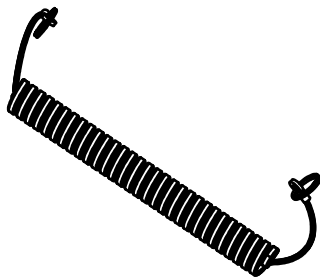

(A9)ELASTIC BELT QTY.1

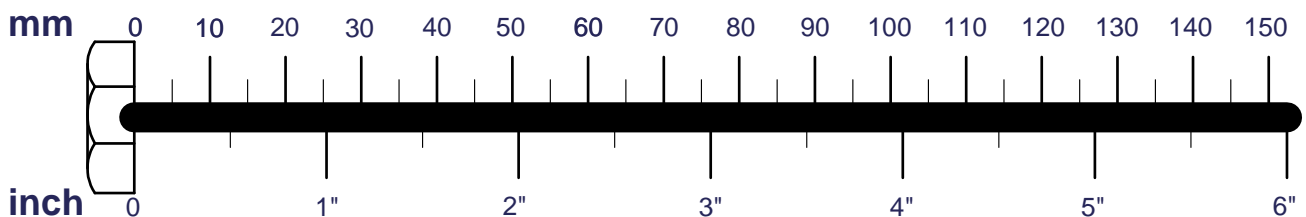

# MCD2100 ASSEMBLY INSTRUCTIONS

## HARDWARE ILLUSTRATION

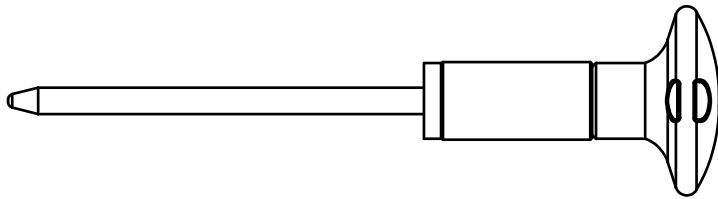

(A11)10、15、20LB PIN (8250-162)QTY.1

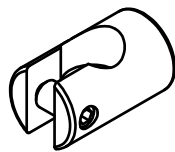

(A12)FIRM SHEATH(8890-010)QTY.1

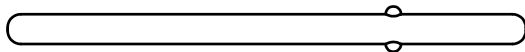

(A13)Ø7.9 FIXED PIN(8250-166) QTY.1

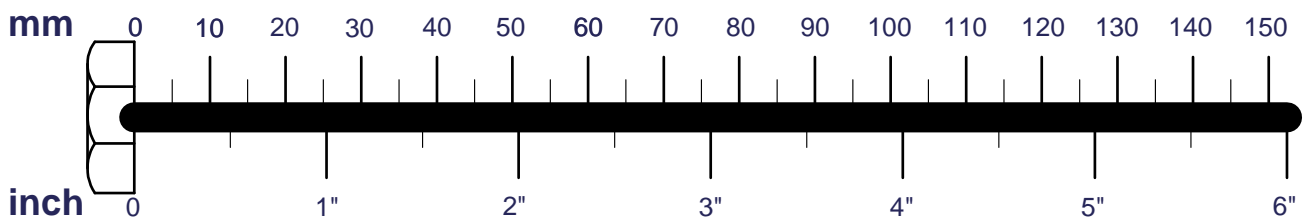

# MCD2100 ASSEMBLY INSTRUCTIONS

## HARDWARE ILLUSTRATION

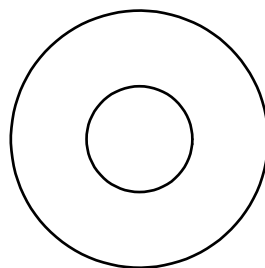
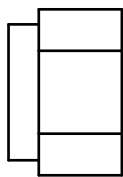
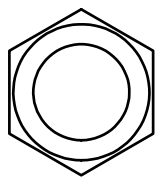

(B1) NYLON LOCK NUT 1/2" QTY.10

(C1) 1/2"(I.D.) FLAT WASHER Ø34 QTY.16

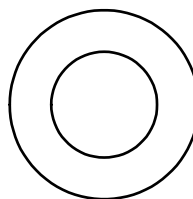
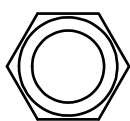

(B2) NYLON LOCK NUT 3/8" QTY.1

(C2) 1/2"(I.D.) FLAT WASHER Ø25 QTY.4

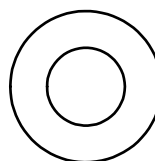
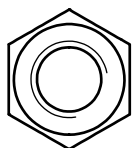

(B3) NYLON LOCK NUT M10 QTY.1

(C3) M10(I.D.) FLAT WASHER Ø20 QTY.2

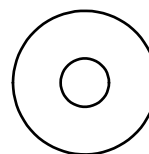

(C4) M6(I.D.) FLAT WASHER Ø19 QTY.12

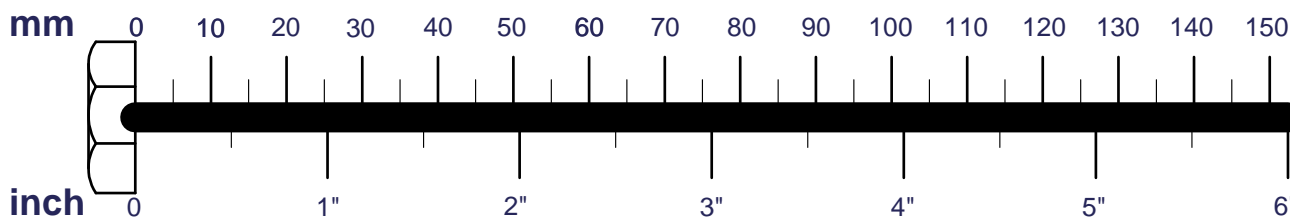

# MCD2100 ASSEMBLY INSTRUCTIONS

## HARDWARE ILLUSTRATION

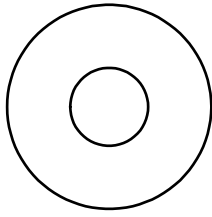

(C5) 3/8" (I.D.) FLAT WASHER Ø27 QTY. 2

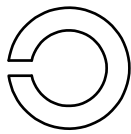

(C6) SPRING WASHER 3/8" QTY. 1

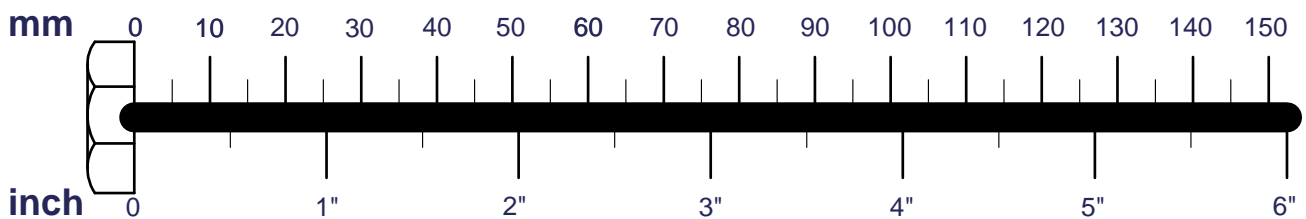

# MCD2100 ASSEMBLY INSTRUCTIONS

## HARDWARE ILLUSTRATION

D1.Ø50 CAP COVER(8130-131)-----	[4PCS]
D2.Ø76 END CAP(9211-076)-----	[2PCS]
D3.Ø3/4" SHAFT COLLAR(9211-147)-----	[2PCS]
D4.50X150L END CAP(9211-162)-----	[6PCS]
D5.Ø63.5xØ26x12.7t RUBBER COUNT(9310-011)-----	[4PCS]
D6.Ø55XØ19.5X32L RUBBER COUNT(9310-027)-----	[2PCS]
D7.108X15tX263L RUBBER PAD(9310-075)-----	[4PCS]
D8.Ø110X22L PULLEY(9213-002B)-----	[1PCS]
D10.WEIGHT SELECTOR BAR(8210-176A)-----	[1PCS]
D11.STEEL CABLE 2300mm(FMCD2100)-----	[1PCS]
D12.STEEL BUSHING (8110-127)-----	[2PCS]
D13.TOP PLATE(8400-033)-----	[1PCS]

D1.

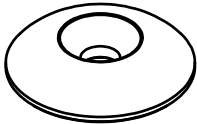

D2.

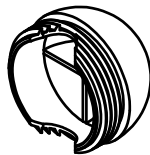

D3.



D4.

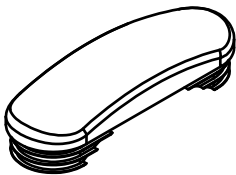

D5.

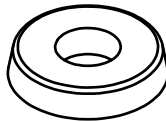

D6.

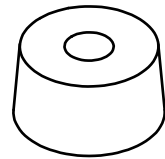

D7.

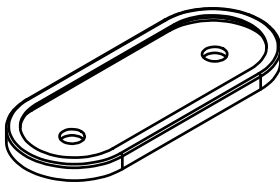

D8.

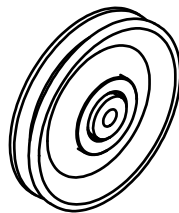

D10.

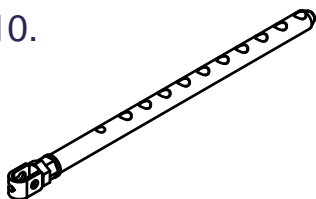

D11.

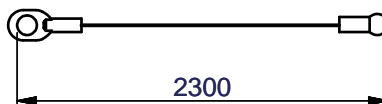

D12.



D13.

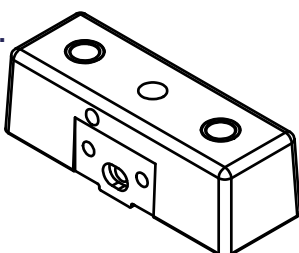

# MCD2100 ASSEMBLY INSTRUCTIONS

## HARDWARE ILLUSTRATION

D14.BOTTLE BRACKET(8388-025)-----[1PCS]  
D15.BOTTLE RACK(9260-320)-----[1PCS]  
D16.BOTTLE(9260-123)-----[1PCS]

D14

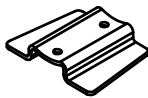

D15

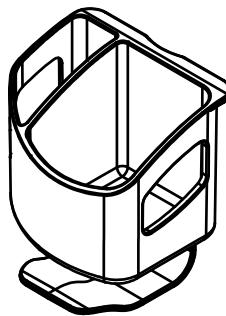

D16



# MCD2100 ASSEMBLY INSTRUCTIONS

## PARTS ILLUSTRATION SHEET

**A2** [1SET]  
20MCD2100-A2

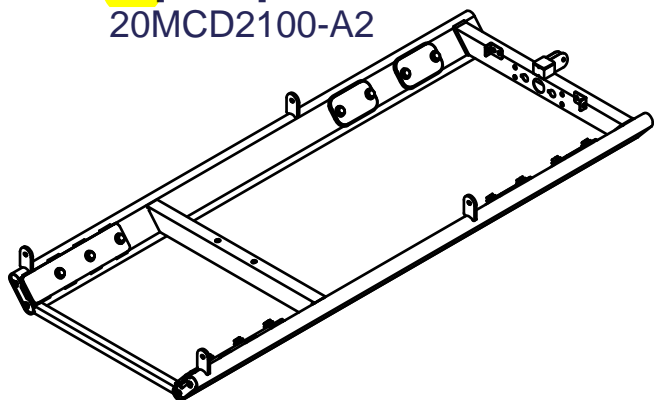

**B2** [1SET]  
20MCD2100-B2

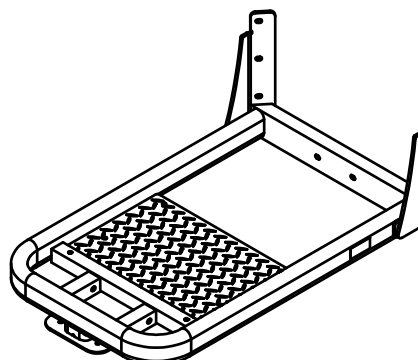

**C2** [1SET]  
20MCD2100-C2

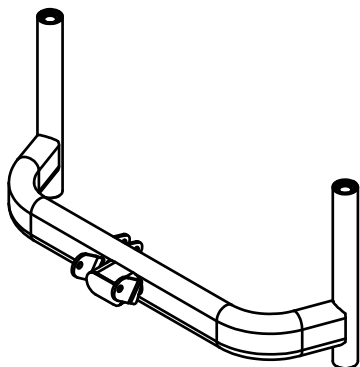

**D1** [1SET]  
20MCD2100-D1

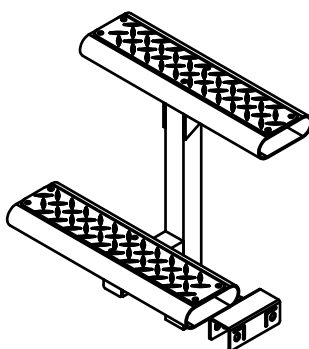

**E** [1SET]  
20MCD2100-E

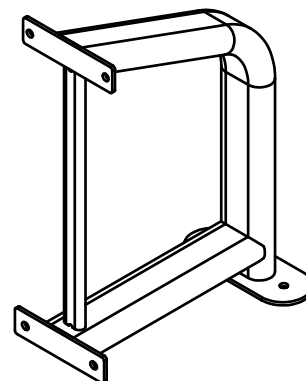

**F** [1SET]  
20MCD2100-F

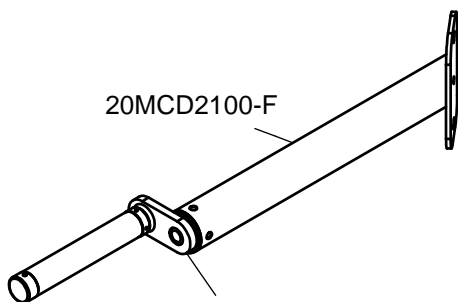

**G1** [2SET]  
20MCD2100-G1

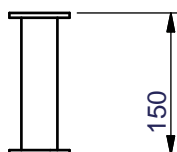

**H1** [1SET]  
20MCD2100-H1

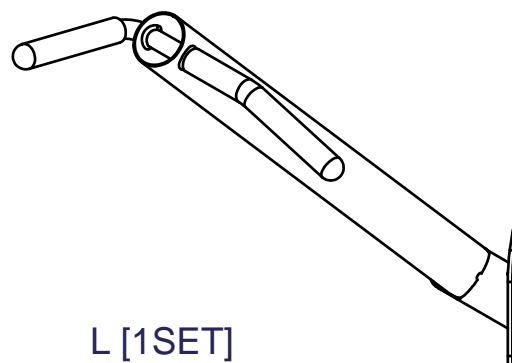

**I1** [1SET]  
20MCD2100-I1

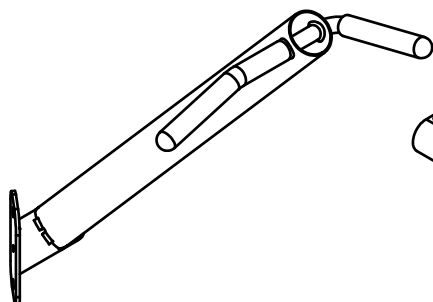

**J1** [1SET]  
20MCD2100-J1

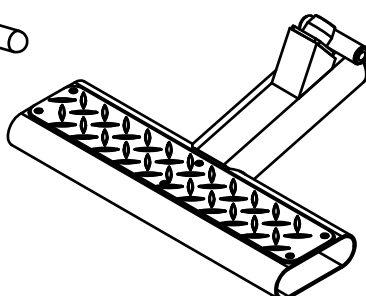

**L** [1SET]  
20MCD2100-L

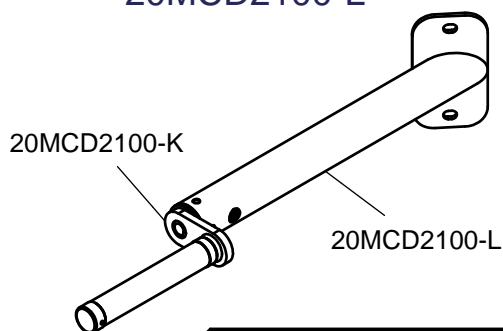

# MCD2100 ASSEMBLY INSTRUCTIONS

## PARTS ILLUSTRATION SHEET

M1 [2PCS]  
8280-046  
Ø25X1235L

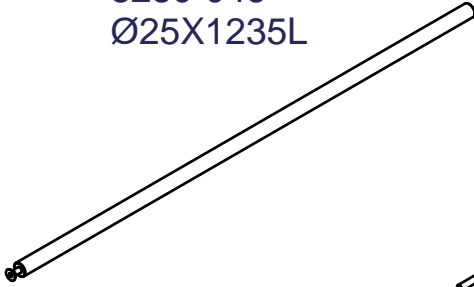

N1 [2PCS]  
8280-042  
Ø3/4"X1433L

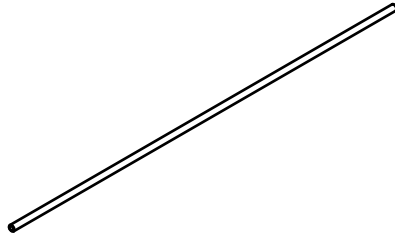

O [1PCS]  
9220-016

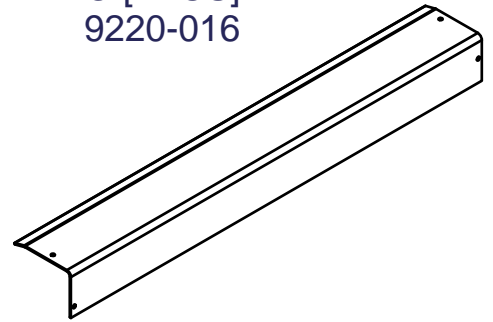

P [1PCS]  
9220-027

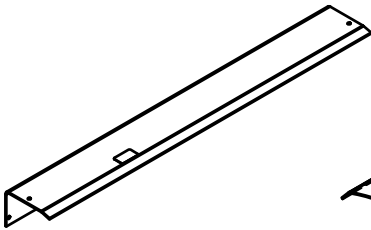

Q [1PCS]  
9220-023

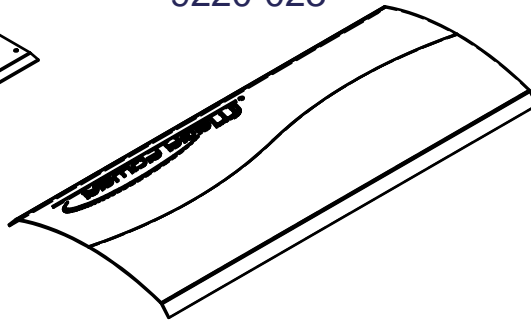

R [1SET]  
9211-148

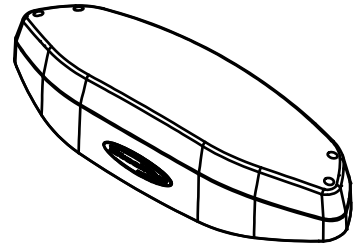

S [2SET]  
8331-056

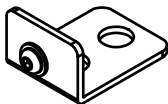

T [4SET]  
8331-057

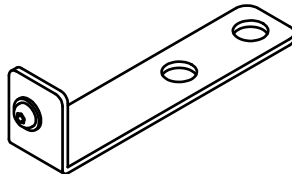

U [1PCS]  
8370-049

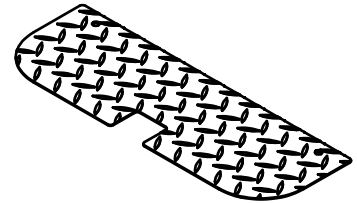

V [1PCS]  
8331-017

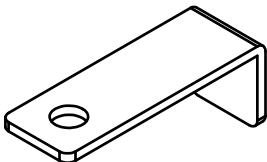

W [1PCS]  
8312-077

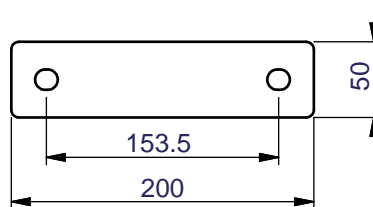

X [1PCS]  
8312-078

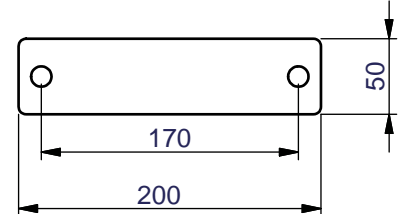

Y [2PCS]  
8313-144

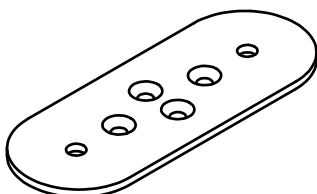

Z [1PCS]  
9420-116  
EXERCISE CHART

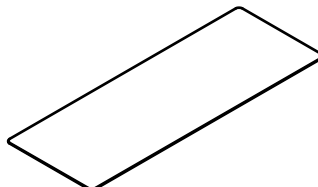

# MCD2100 ASSEMBLY INSTRUCTIONS

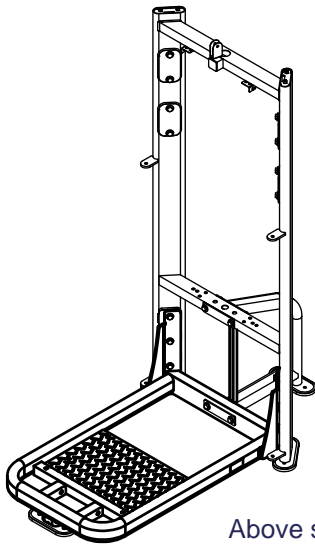

Above shows STEP 1 assembled and completed

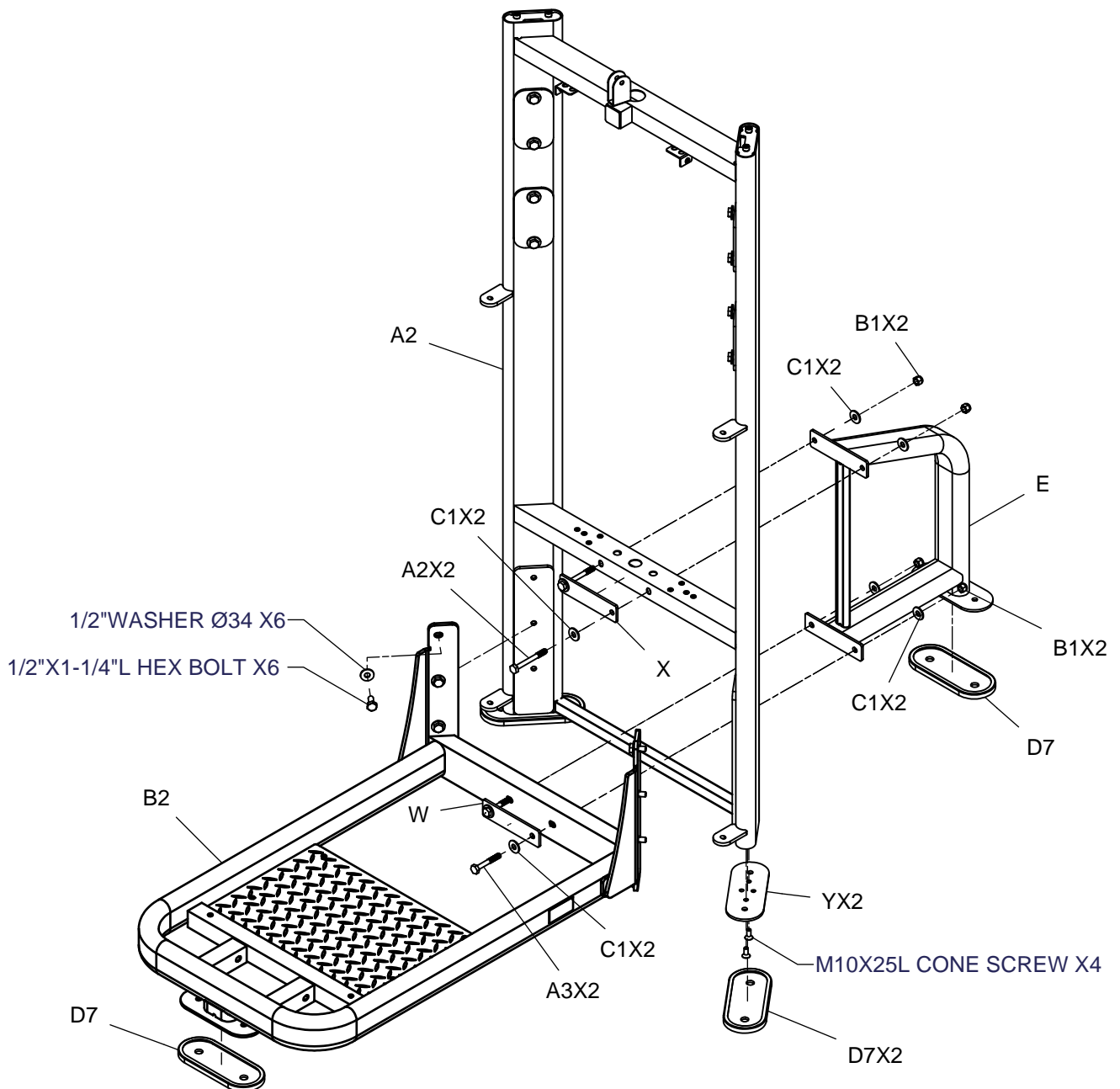

# MCD2100 ASSEMBLY INSTRUCTIONS

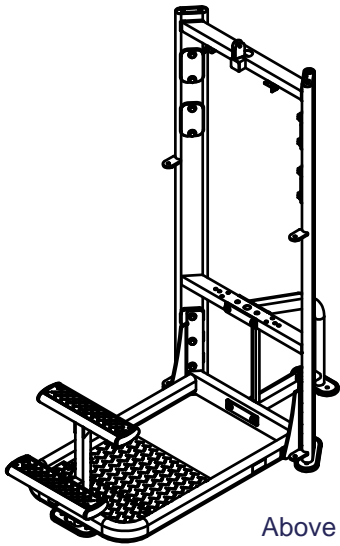

Above shows STEP 2 assembled and completed

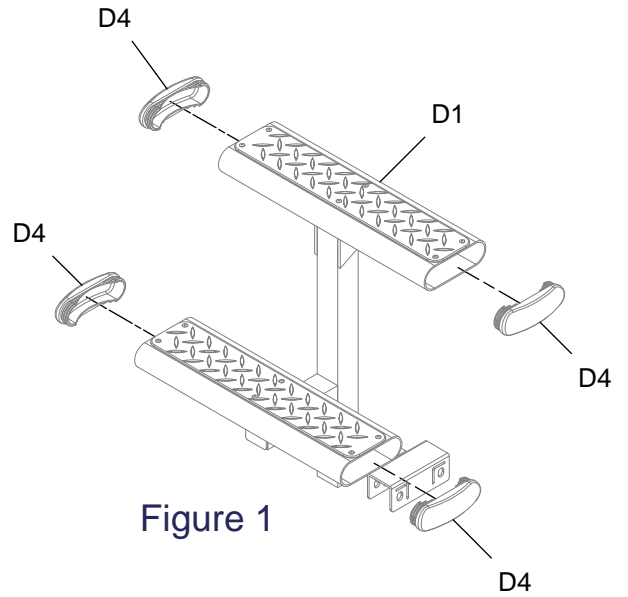
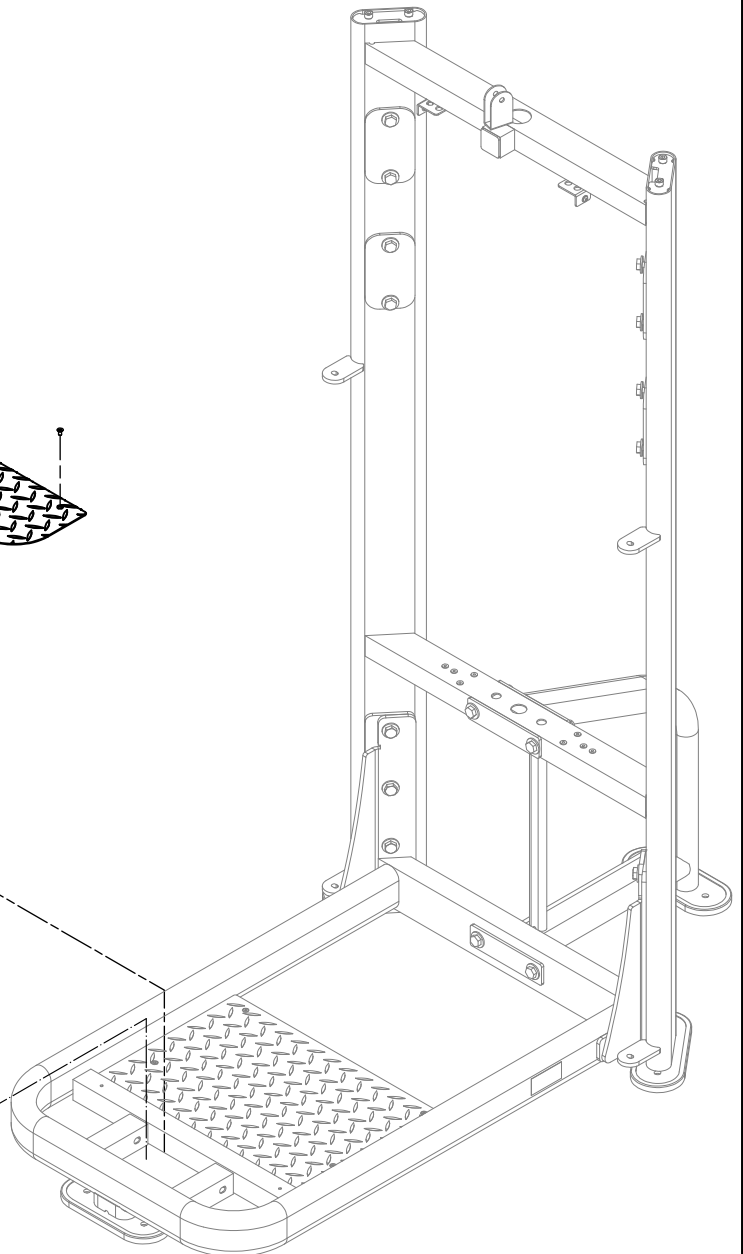
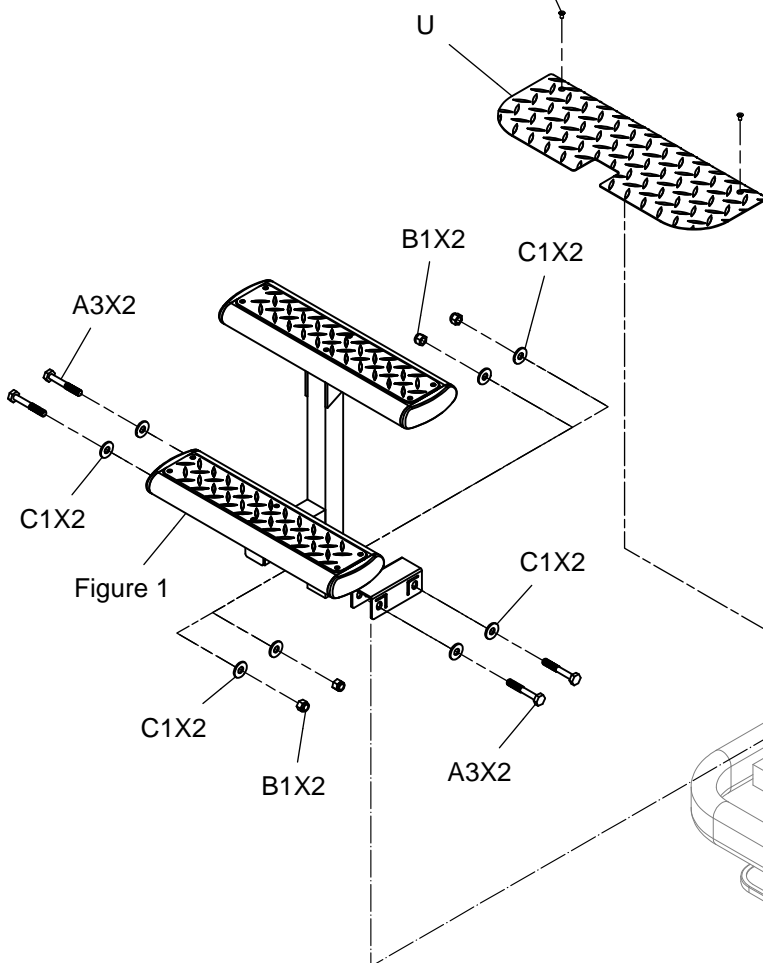
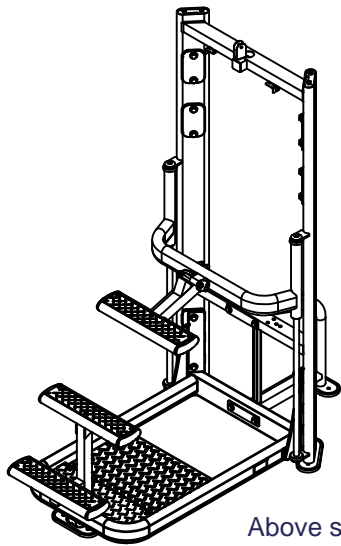

Figure 1

M6X12L CONE SCREW X6



# MCD2100 ASSEMBLY INSTRUCTIONS



Above shows STEP 3 assembled and completed

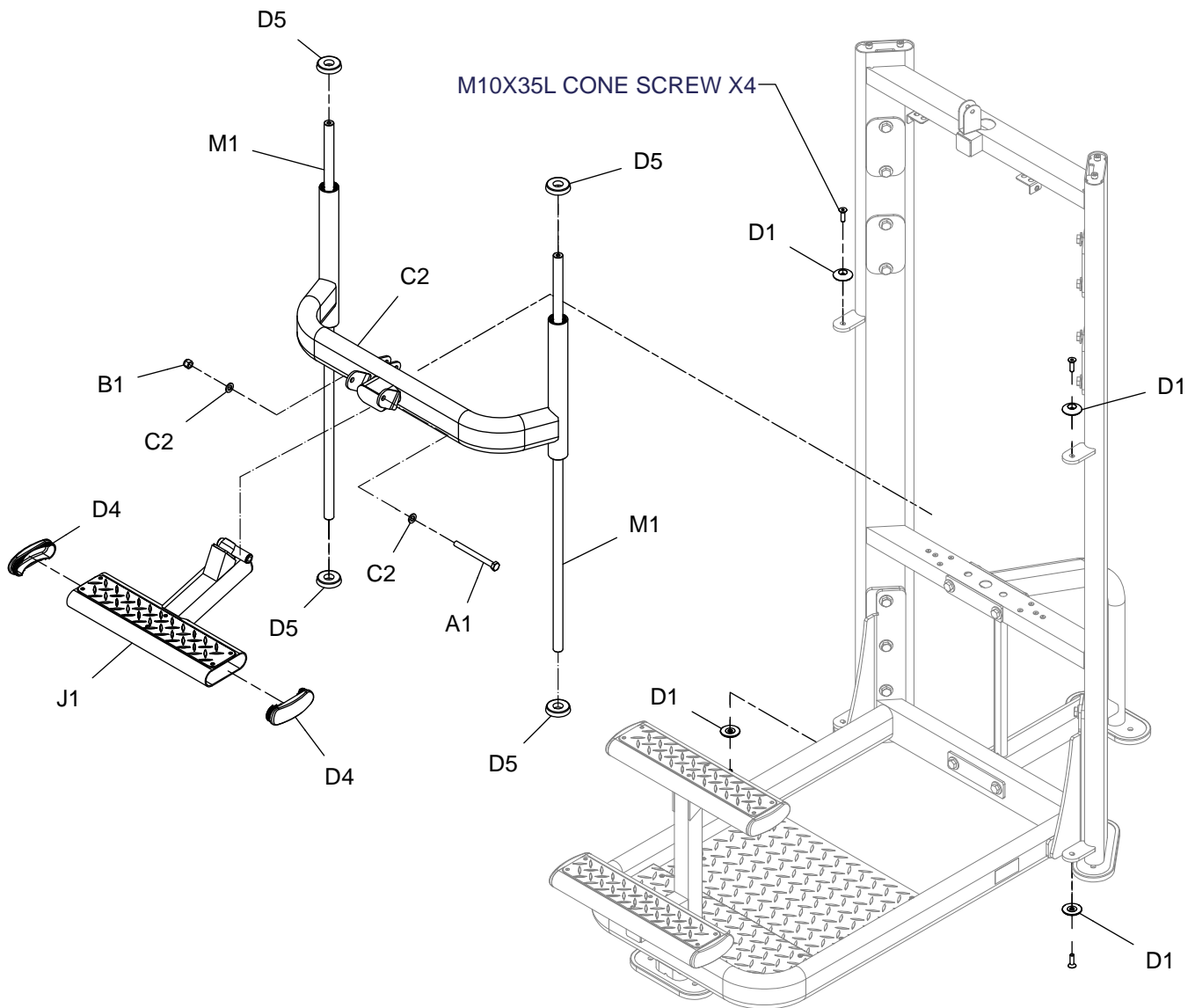

# MCD2100 ASSEMBLY INSTRUCTIONS

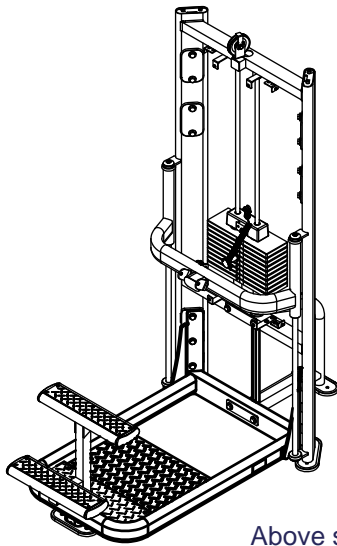

Above shows STEP 5 assembled and completed

Note : Insert A13 through the hole of the Third electing plate and fix it permanently

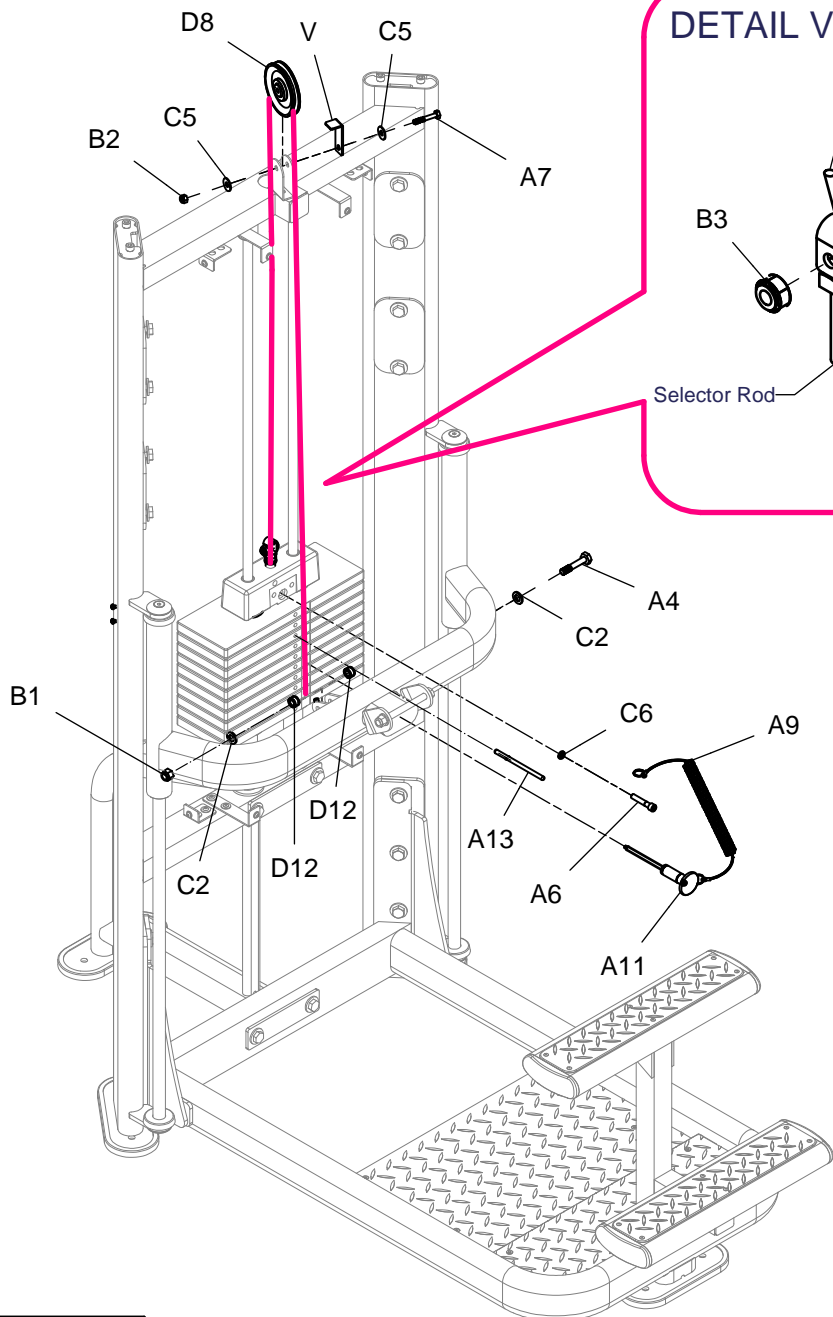

## DETAIL VIEW

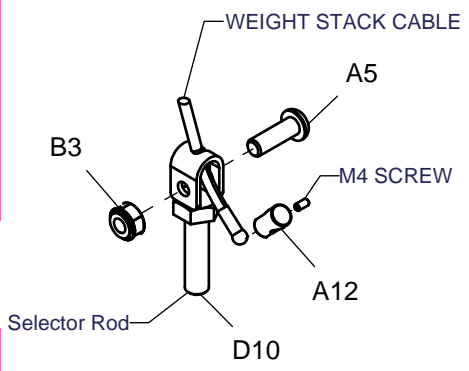

# MCD2100 ASSEMBLY INSTRUCTIONS

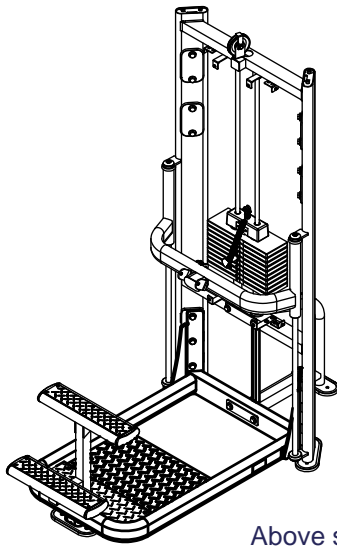

Above shows STEP 5 assembled and completed

Note : Insert A10 through the hole of the Third electing plate and fix it permanently

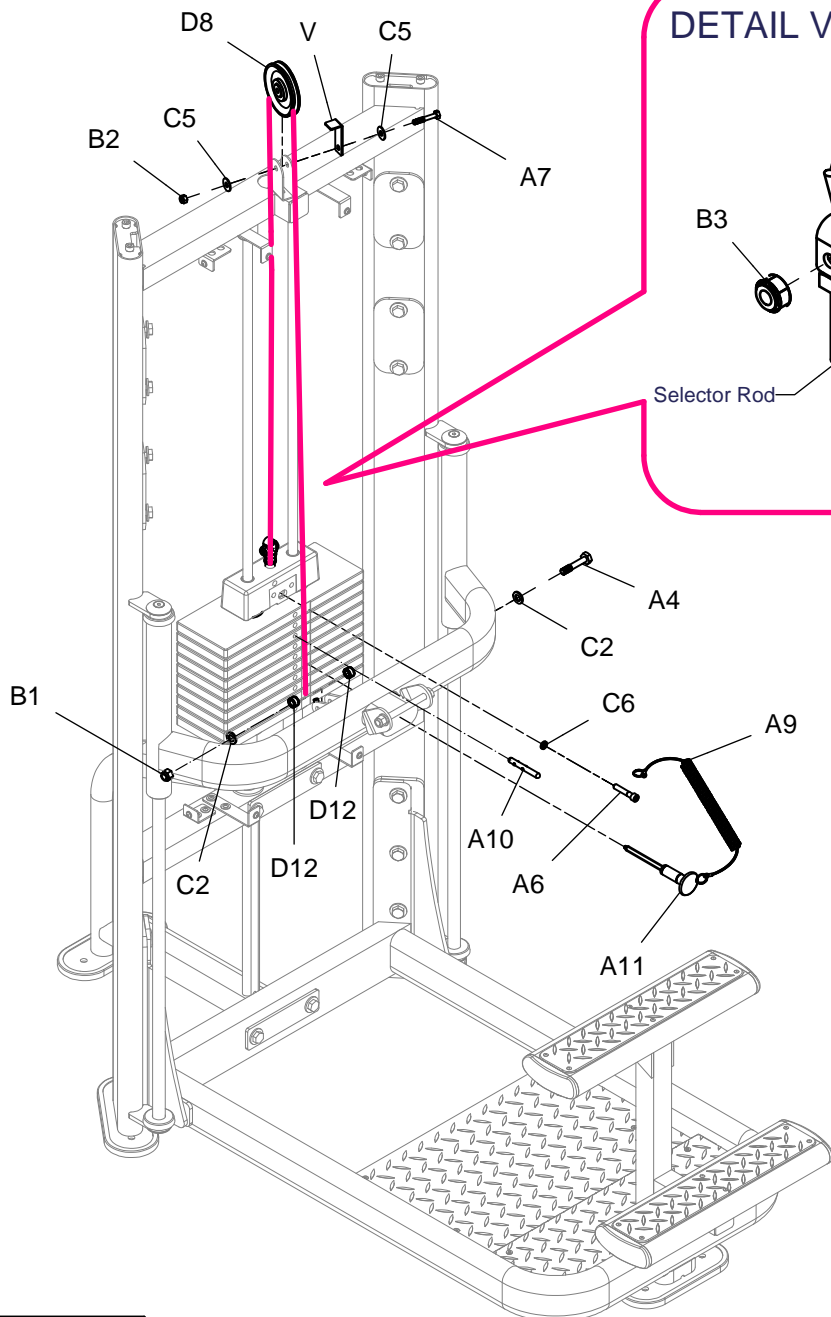

## DETAIL VIEW

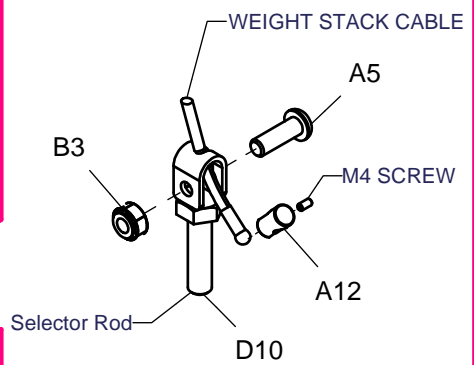

# MCD2100 ASSEMBLY INSTRUCTIONS

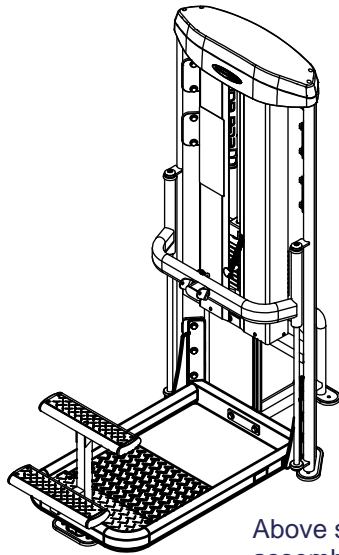

M10X12L ROUND INNER HEAD X4

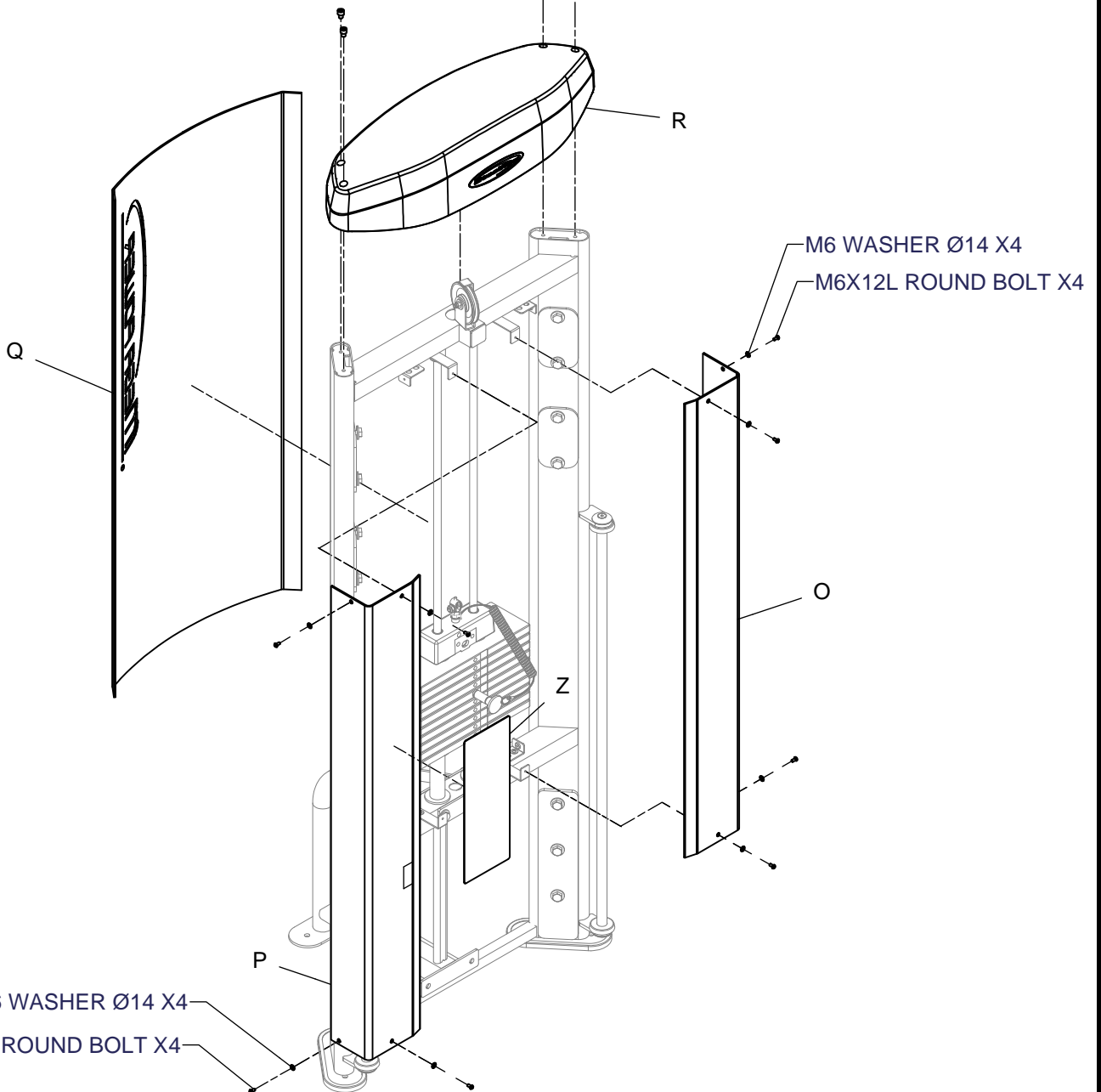

# MCD2100 ASSEMBLY INSTRUCTIONS

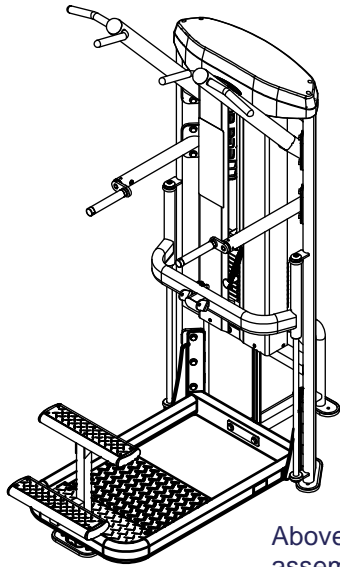

Above shows STEP 7  
assembled and completed

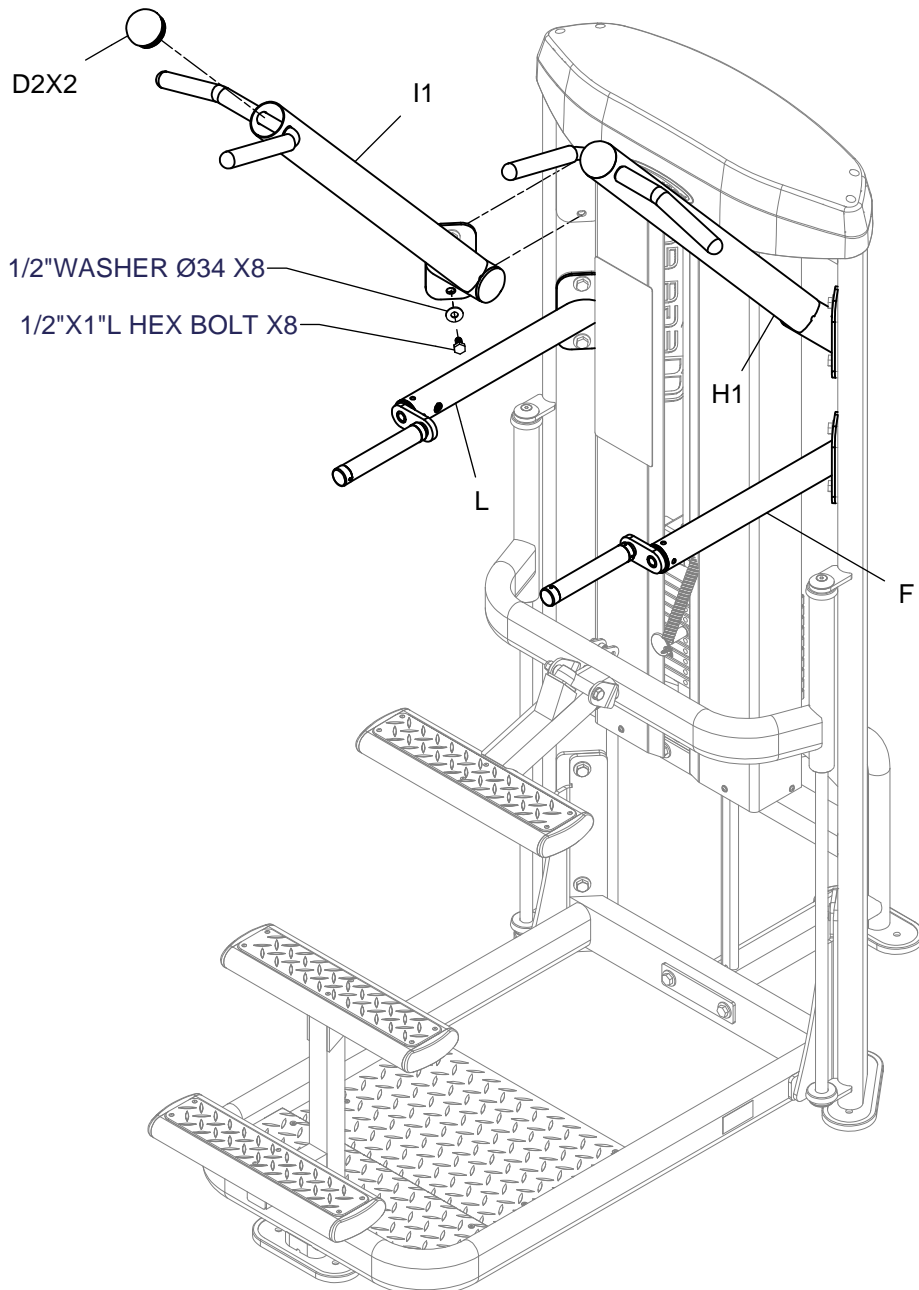

# MCD2100 ASSEMBLY INSTRUCTIONS

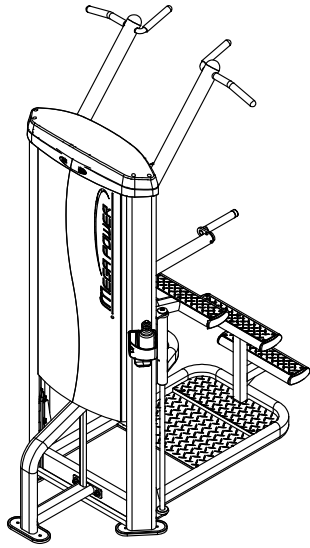

Above shows STEP 8  
assembled and completed

STEP 7

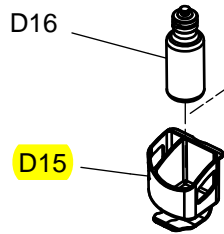

D14

M4X12L Round cross screw X2

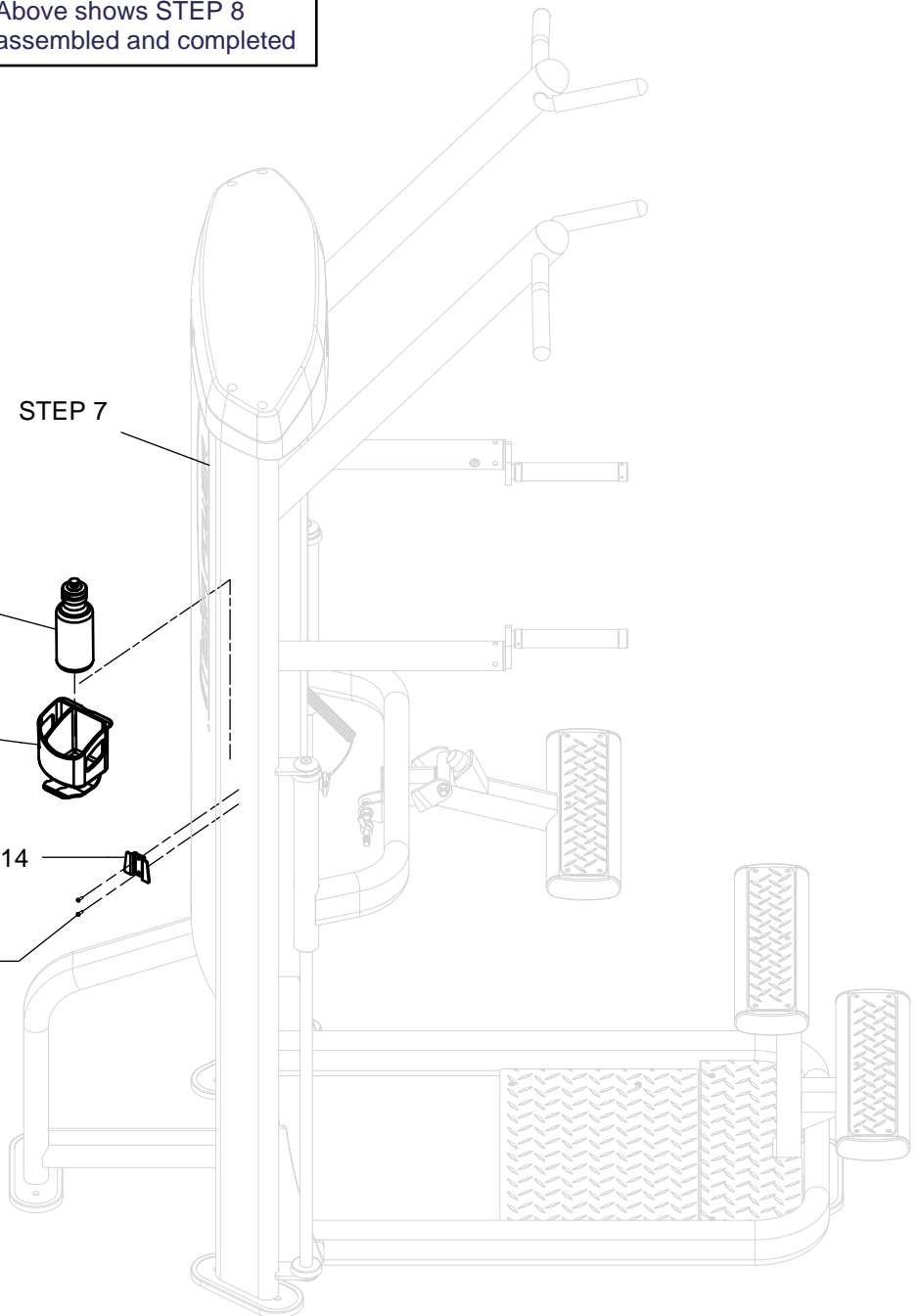

## Guide on Selector Rod Adjustment

### STEP 1

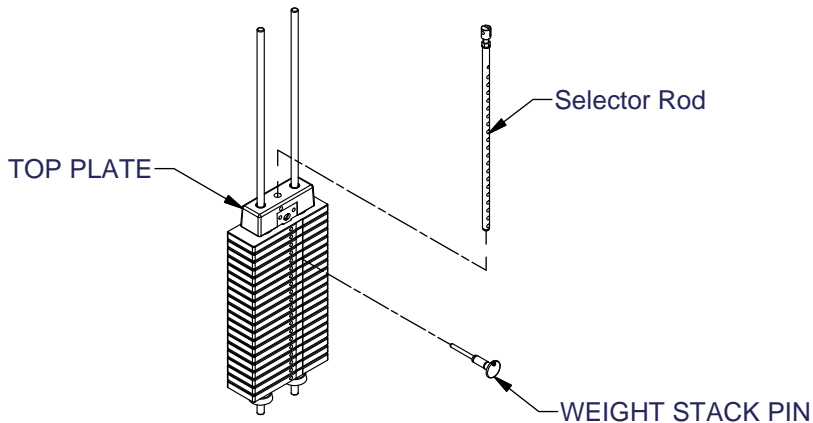

Step 1  
Place Selector Rod into Top Plate.  
Then put selector pin into the weight plate to fix the rod.

### STEP 2

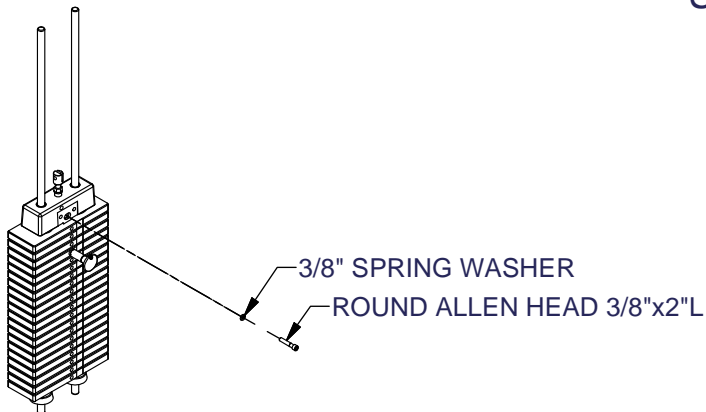

Step 2  
Screw the 3/8"x2"L Round Allen Head  
into Top Plate but not tighten it up.

### STEP 3

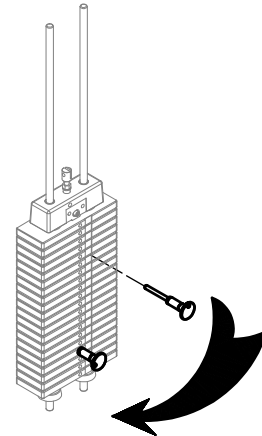

Step 3  
Place the selector pin to each weight plate  
(5,10,15,20...) to check the smoothness.

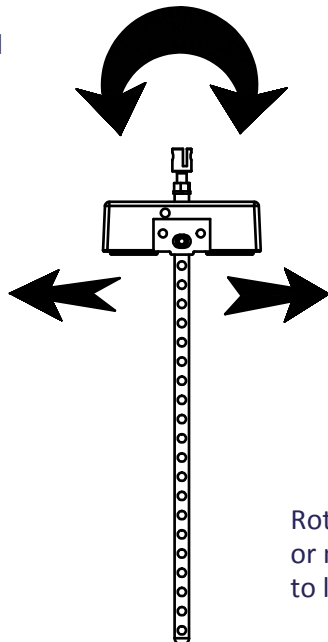

Rotate the Selector Rod slightly  
or move the 3/8"x2"L Round Allen Head  
to left and right and repeat Step 3.