

HORPE

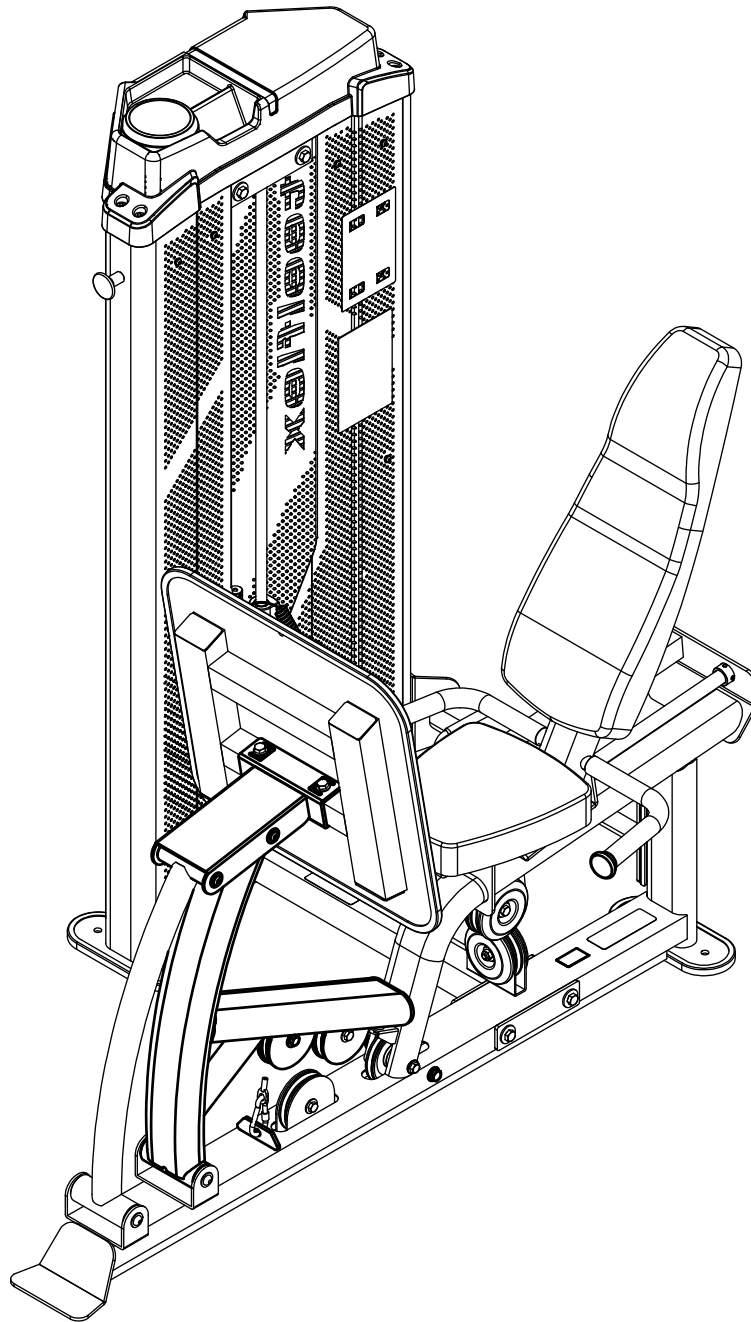

Steelflex

JOONG CHENN INDUSTRY CO., LTD.

Sales Office:

3F28, No.5, Shin-Yi Rd., Sec. 5, Taipei, Taiwan 110 R.O.C.

Tel: 886-2-27209980

Fax: 886-2-27229750

www.steelflexfitness.com

HLP-500.3 OWNER'S MANUAL

HLP500 ASSEMBLY INSTRUCTIONS

HARDWARE ILLUSTRATION

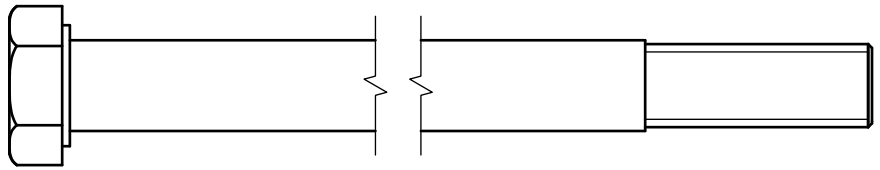
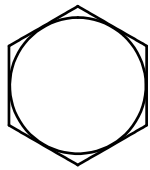

(A1)HEX BOLT M12X135L PARTIAL THREAD QTY.2

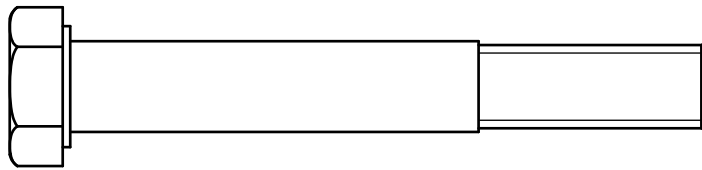
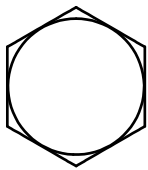

(A2)HEX BOLT M12X85L PARTIAL THREAD QTY.4

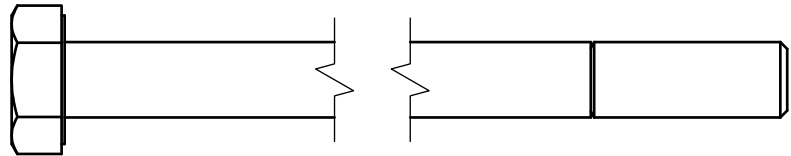
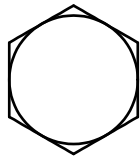

(A3)HEX BOLT M10X120L PARTIAL THREAD QTY.1

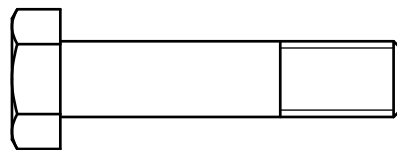
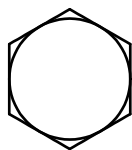

(A4)HEX BOLT M10X45L PARTIAL THREAD QTY.3

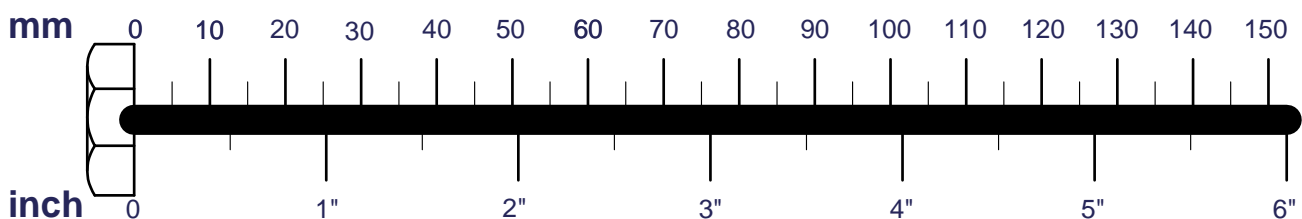

HLP500 ASSEMBLY INSTRUCTIONS

HARDWARE ILLUSTRATION

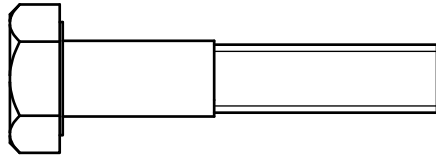
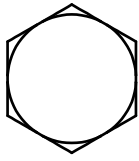

(A6)HEX BOLT M10X50L PARTIAL THREAD QTY.2

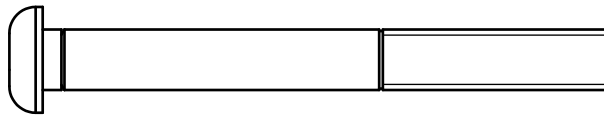
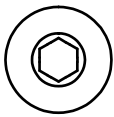

(A7)HEX BOLT M8X75L PARTIAL THREAD QTY.2

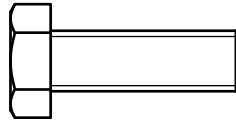
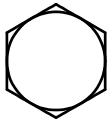

(A8)HEX BOLT M8X25L PARTIAL THREAD QTY.3

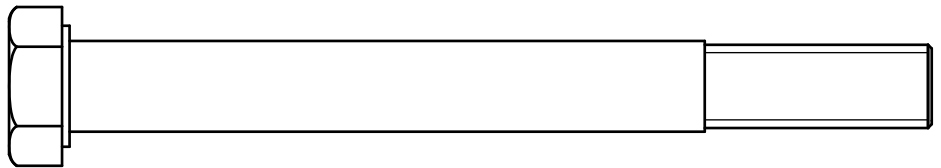
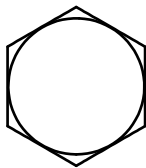

(A9)HEX BOLT M12X115L PARTIAL THREAD QTY.1

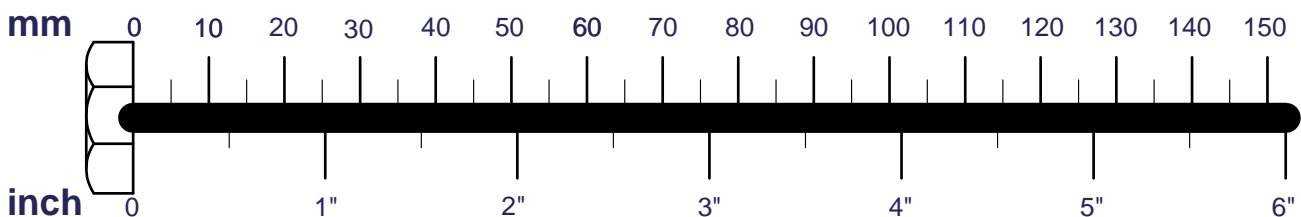

HLP500 ASSEMBLY INSTRUCTIONS

HARDWARE ILLUSTRATION

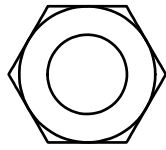

(B1) NYLON LOCK NUT M12 QTY.7



(B2) NYLON LOCK NUT M10 QTY.6

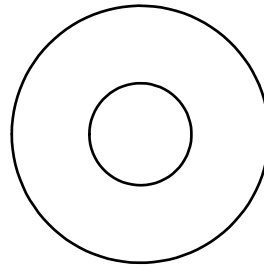

(C1) M12(I.D.) FLAT WASHER Ø34 QTY.8



(C2) M12(I.D.) FLAT WASHER Ø25 QTY.6

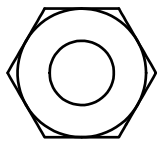

(C3) M10(I.D.) FLAT WASHER Ø27 QTY.10

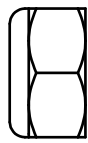

(C5) M8(I.D.) FLAT WASHER Ø24 QTY.5

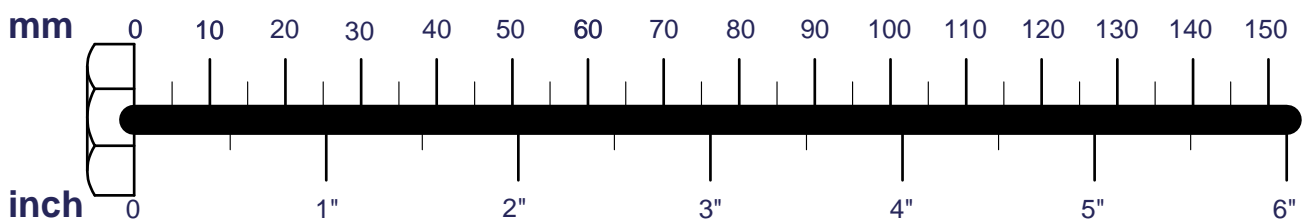
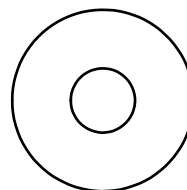
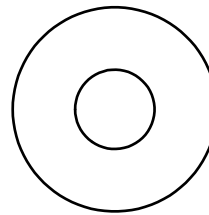

HLP500 ASSEMBLY INSTRUCTIONS

HARDWARE ILLUSTRATION

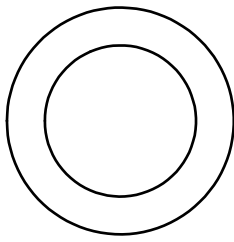

(C6)M20(I.D.)FLAT WASHER Ø30 QTY.4

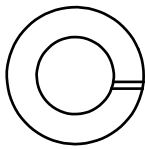

(C7)SPRING WASHER M10 QTY.2

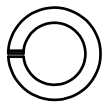

(C8)SPRING WASHER M8 QTY.5

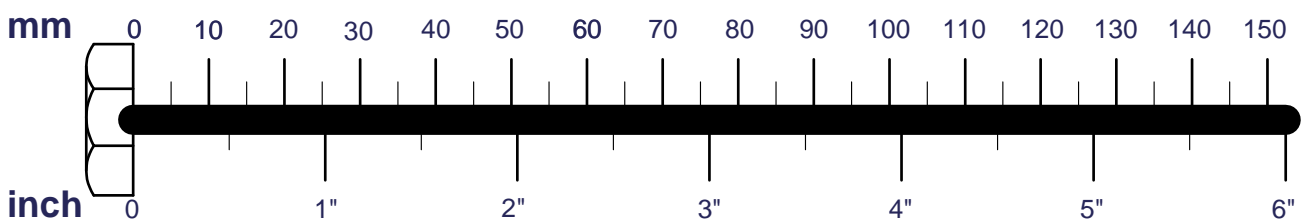

HLP500 ASSEMBLY INSTRUCTIONS

FRAME HARDWARE ILLUSTRATION

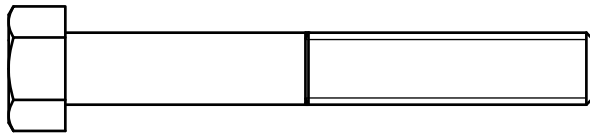
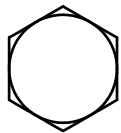

(AA2)HEX BOLT 3/8"X2-3/4"L PARTIAL THREAD QTY.1

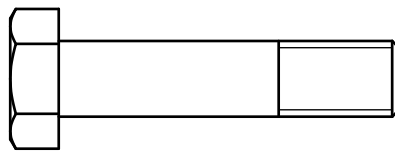
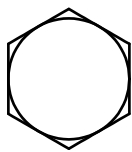

(AA3)HEX BOLT M10X45L PARTIAL THREAD QTY.2

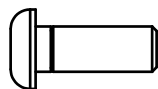

(AA4)ROUND INNER HEX SCREW M6x16L PARTIAL THREAD QTY.24

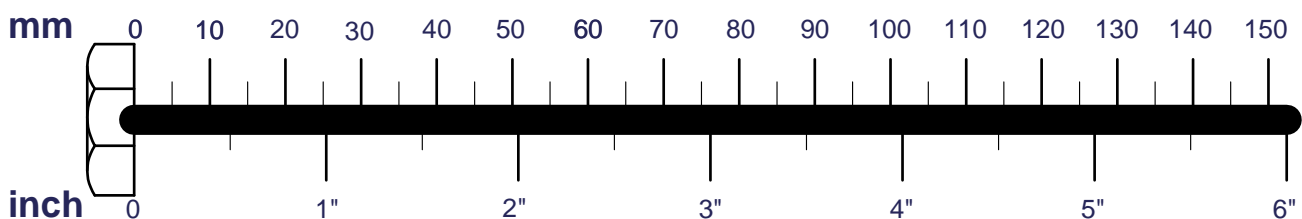

HLP500 ASSEMBLY INSTRUCTIONS

FRAME HARDWARE ILLUSTRATION

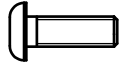

(AA5)ROUND INNER HEX SCREW M4x12L PARTIAL THREAD QTY.4

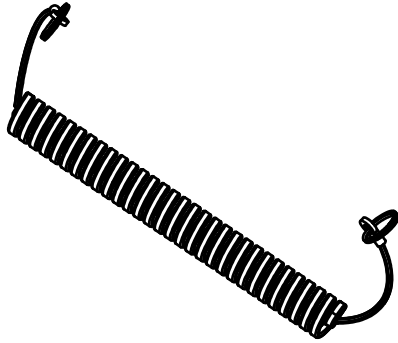

(AA7)ELASTIC BELT QTY.1

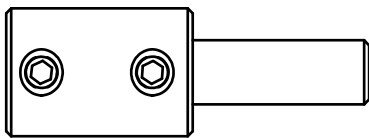

(AA8)RT3(8260-009) QTY.1

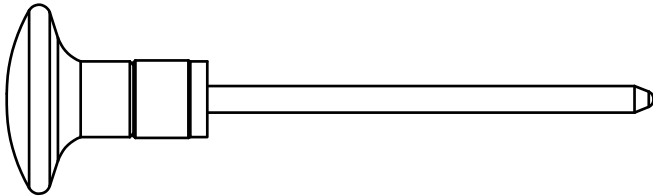

(AA9)20LB PIN(8250-152) QTY.1

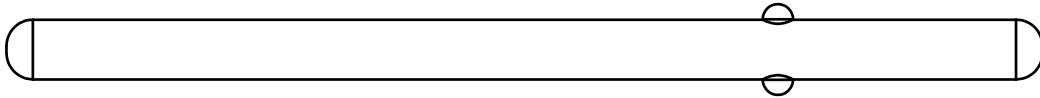

(AA10)Ø5/16" FIXED PIN (8250-166) QTY.1

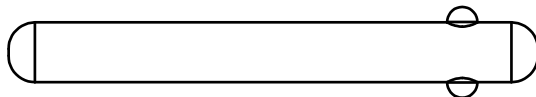

(AA11)Ø5/16" FIXED PIN (8250-167) QTY.1

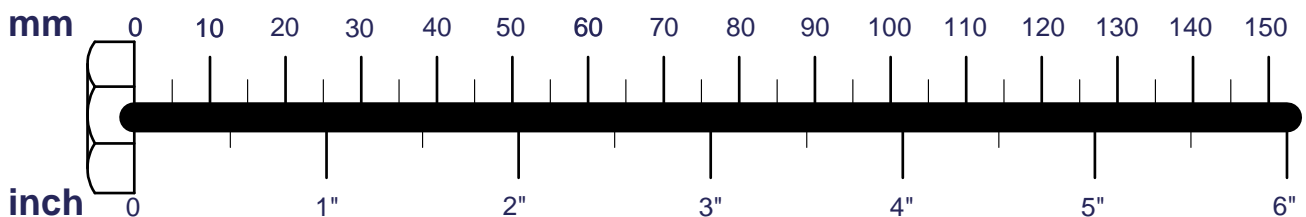

HLP500 ASSEMBLY INSTRUCTIONS

HARDWARE ILLUSTRATION

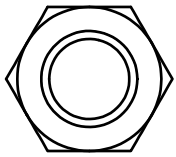

(BB1) 1/2" NUT-13UNC QTY.1

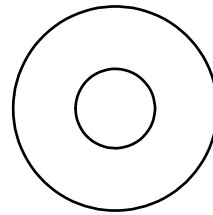

(CC1) M10(I.D.) FLAT WASHER Ø27 QTY.5

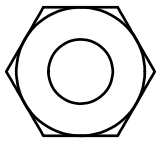

(BB2) NYLON LOCK NUT M10 QTY.2

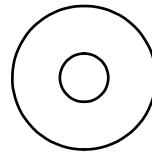
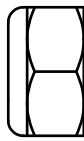

(CC2) M6(I.D.) FLAT WASHER Ø19 QTY.24



(BB3) NYLON LOCK NUT M4 QTY.4



(CC3) M4(I.D.) FLAT WASHER Ø10 QTY.8

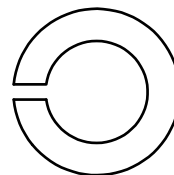

(CC5) SPRING WASHER 1/2" QTY.1

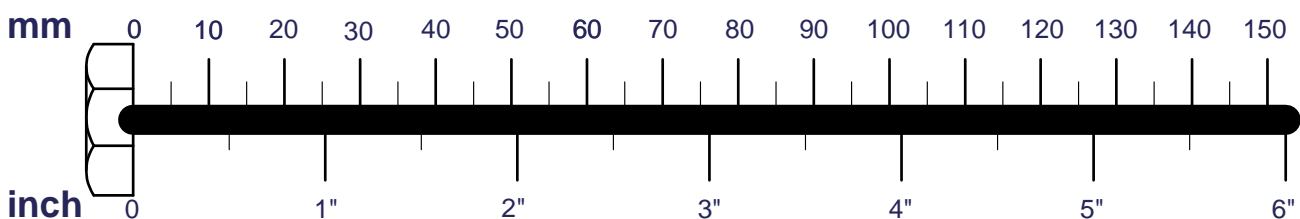

HLP500 ASSEMBLY INSTRUCTIONS

HARDWARE ILLUSTRATION

D1.Ø25XØ11X42L STEEL BUSHIING(8120-097)-----	[2PCS]
D2.Ø8 SPRING SNAP LINK(8810-005)-----	[1PCS]
D3.60X45 NYLON BUSHING(9211-032)-----	[2PCS]
D4.50X100X2.0tX30H END CAP(9211-114)-----	[1PCS]
D5.Ø1"X39t RUBBER END CAP(9212-019)-----	[1PCS]
D6.120x1.3tx195L FRICTION TAPE(9310-041)-----	[1PCS]
D7.108X14.5tX263L RUBBER PAD(9310-075)-----	[1PCS]
D8.Ø110X22 PULLEY (9213-002B)-----	[6PCS]
D9.TENSION SPRING(8840-060)-----	[1PCS]
D10.Ø116X17 CAP COVRE(9211-173)-----	[4PCS]
D12.HLP500 FOR HDC STEEL CABLE(FHLP500B2)-----	[1PCS]

D1.

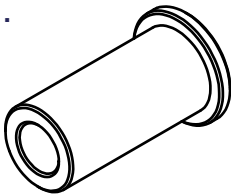

D2.

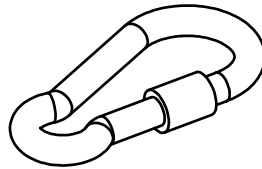

D3.

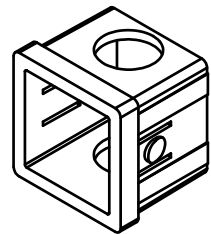

D4.

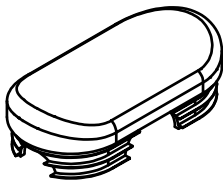

D5.

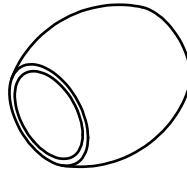

D6.

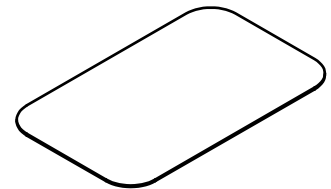

D7.

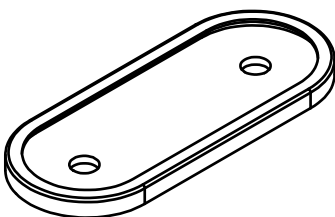

D8.

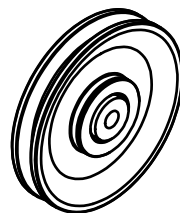

D9.

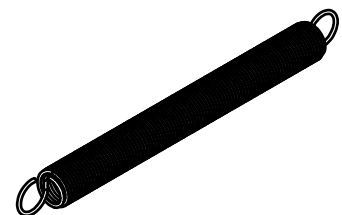

D10.

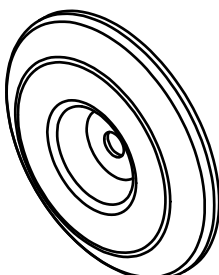

D12.

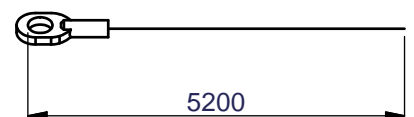

HLP500 ASSEMBLY INSTRUCTIONS

FARME HARDWARE ILLUSTRATION

DD1.Ø3/4" SHAFT COLLAR(9211-046)-----	[2PCS]
DD2.50X4tX50L RUBBER PAD(9214-002)-----	[3PCS]
DD3.Ø50X33.5L PLASTICS BAR(9215-024)-----	[1PCS]
DD4.Ø65XØ20X70L RUBBER DOUNT(9310-049)-----	[2PCS]
DD6.108X14.5tX263L RUBBER PAD(9310-075)-----	[2PCS]
DD7.Ø110X22 PULLEY (9213-002B)-----	[2PCS]

DD1.



DD2.

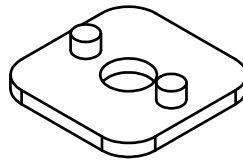

DD3.

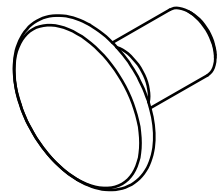

DD4.

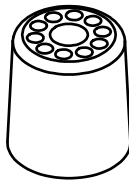

DD6.

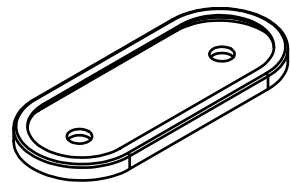

DD7.

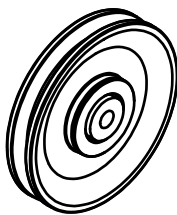

HLP500 ASSEMBLY INSTRUCTIONS

PARTS ILLUSTRATION SHEET

A1 [1SET]

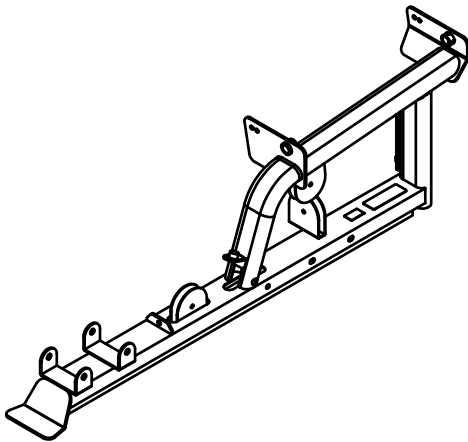

B3 [1SET]

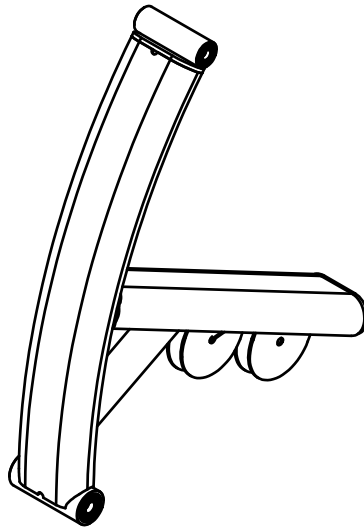

C1 [1SET]

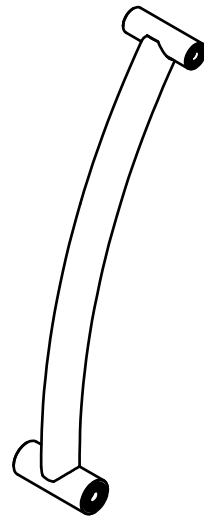

D1 [1SET]

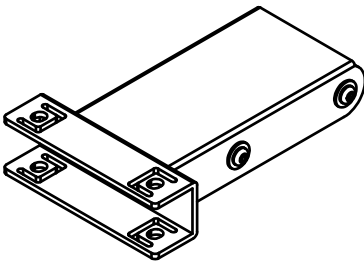

E [1SET]

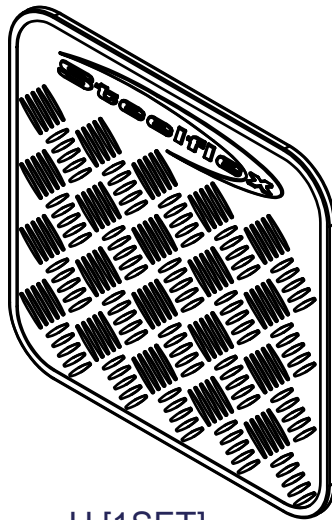

F1 [1SET]

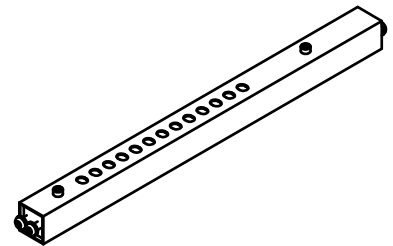

G1 [1SET]

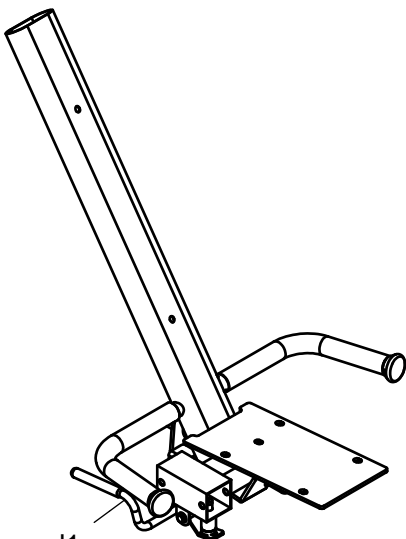

H [1SET]

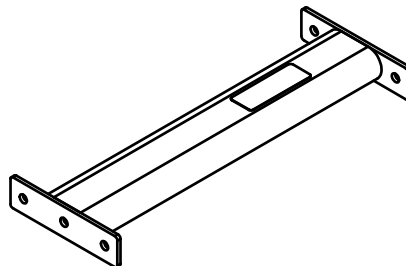

I [1SET]

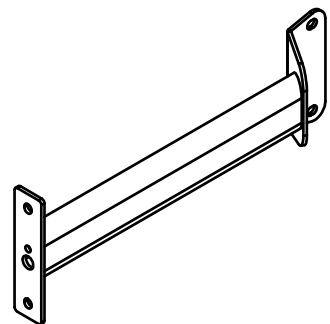

J1

PARTS ILLUSTRATION SHEET

L [2SET]
8210-172
Ø17X144L

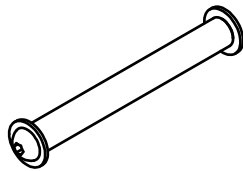

N [1PCS]
8280-035
Ø25X660L

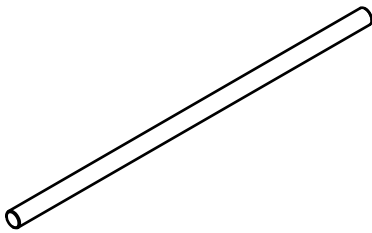

O [2PCS]
8312-077

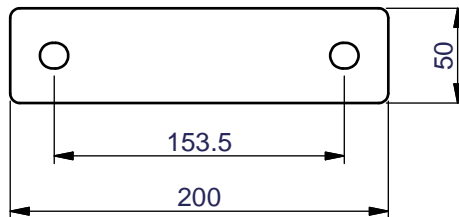

P [1PCS]
9420-081

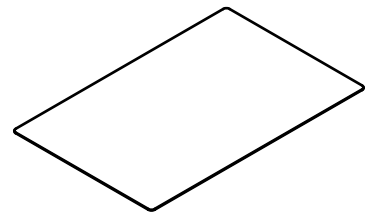

Q [1PCS]
8313-188

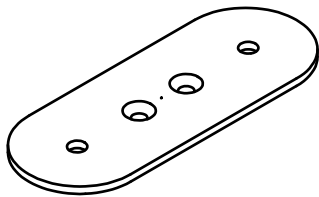

S [1SET]
9111-090

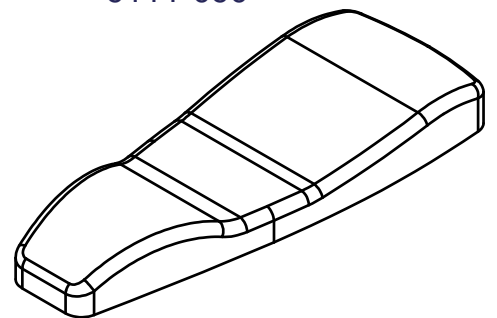

T [1SET]
9121-092

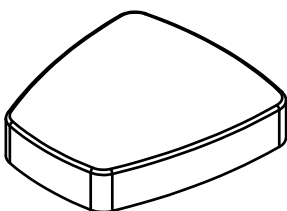

HLP500 ASSEMBLY INSTRUCTIONS

FARME PARTS ILLUSTRATION SHEET

AA_B [1SET]
6610-020

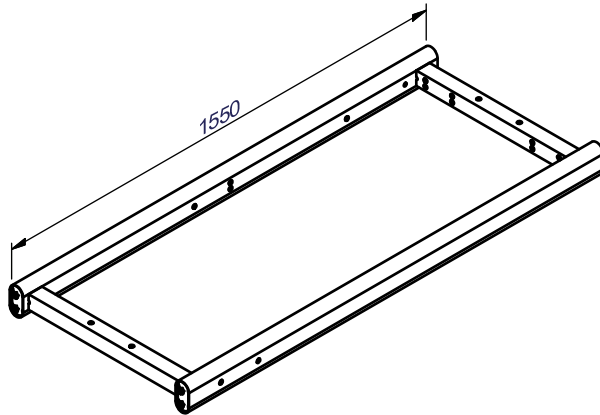

AB [1SET]
6610-017

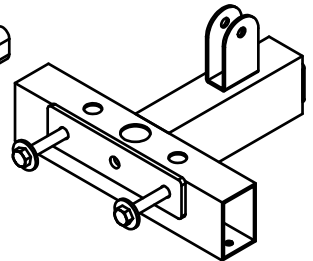

AC [1PCS]
6610-018

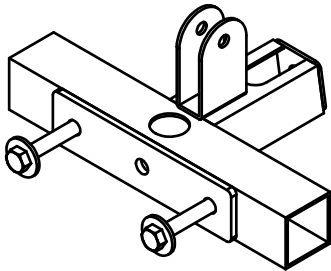

AD [1PCS]
9211170-023

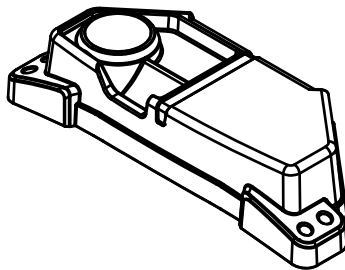

AE_B [1PCS]
8380-069

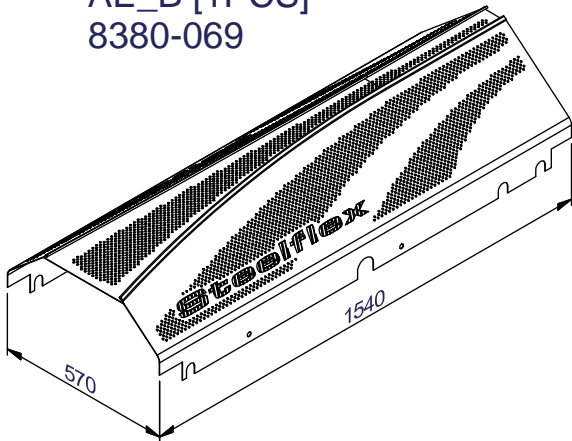

AF_B [1SET]
8380-070

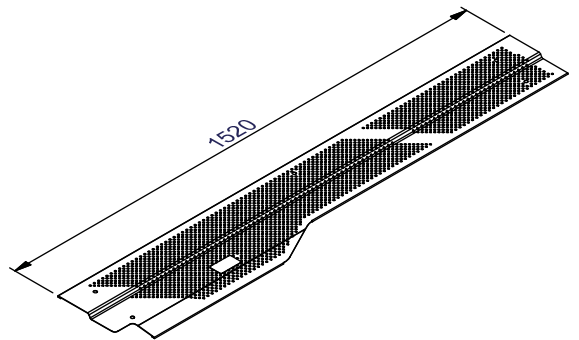

AG_B [1PCS]
8380-071

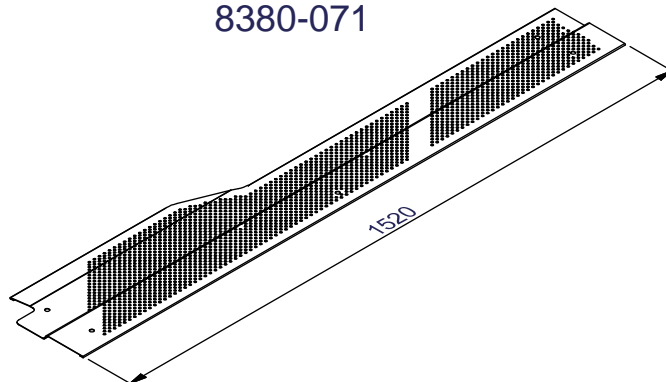

AH [1SET]
8400-006

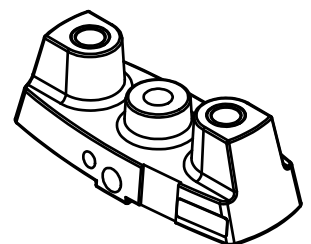

HLP500 ASSEMBLY INSTRUCTIONS

FARME PARTS ILLUSTRATION SHEET

AI_A1 [1PCS]
8210-191

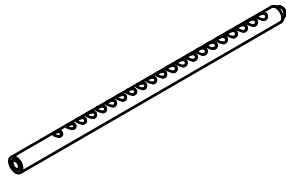

AJ[6SET]
8331-064

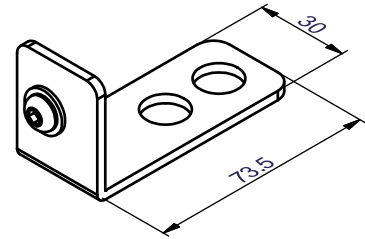

AK[4SET]
8331-065

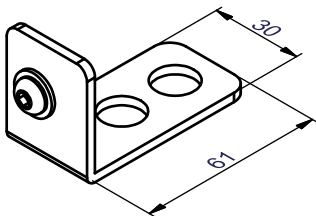

AL[2PCS]
8313-188

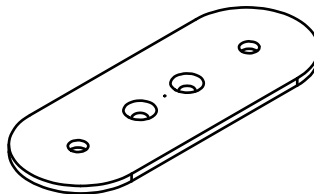

AM [1PCS]
8331-017

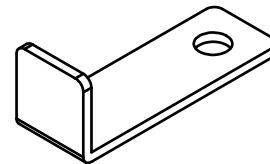

AN_B2 [2PCS]
8280-037
Ø19X1522L

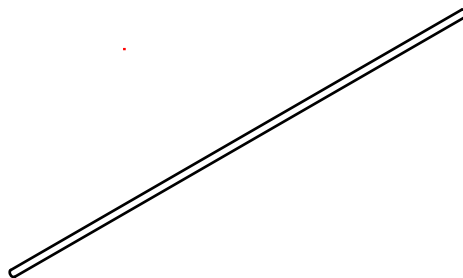

AO [1PCS]
8345-014

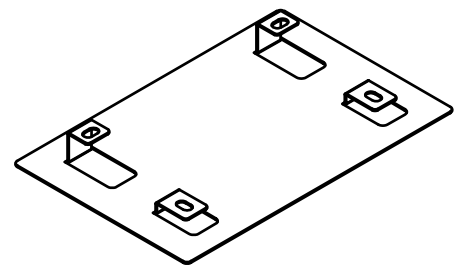

AP [1PCS]
8311-194

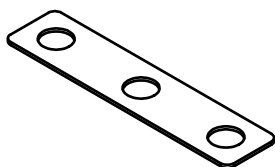

HLP500 ASSEMBLY INSTRUCTIONS

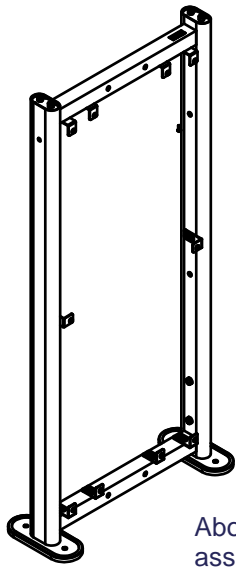

Above shows STEP 1
assembled and completed

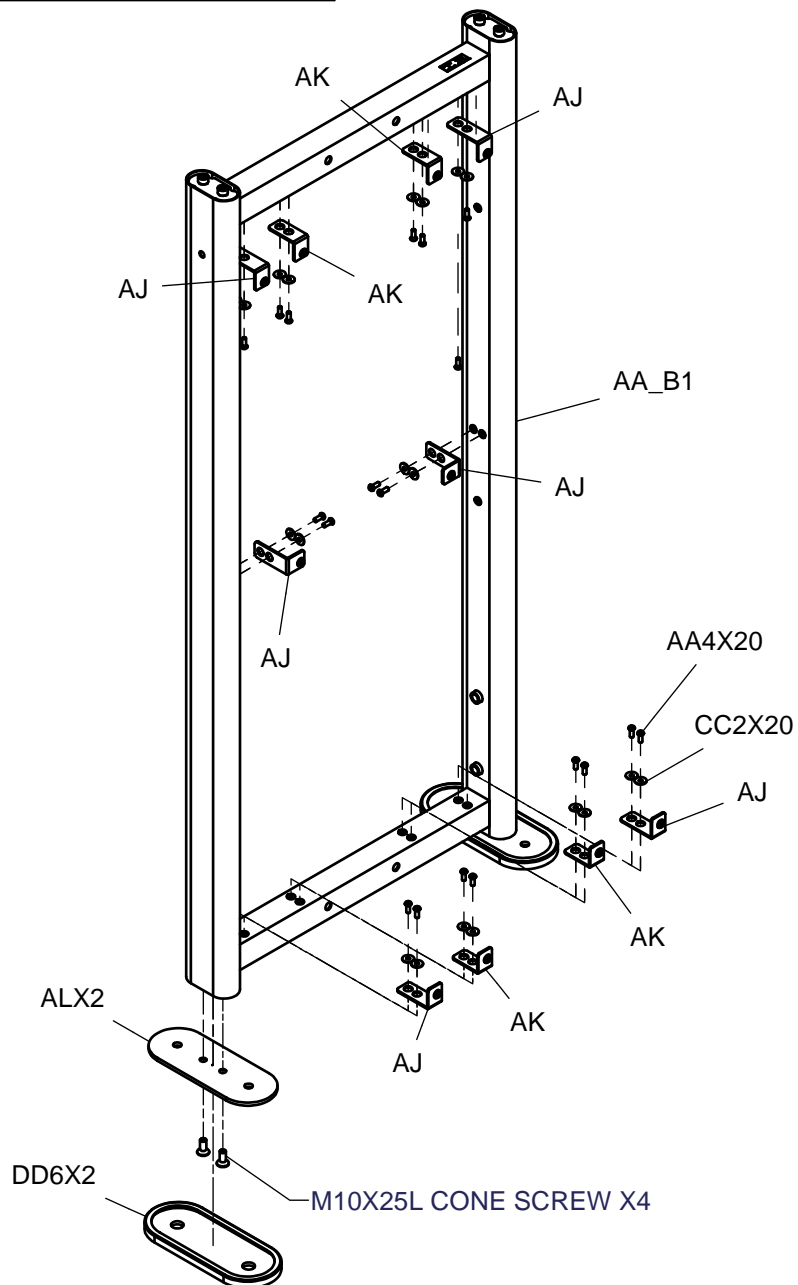

HLP500 ASSEMBLY INSTRUCTIONS

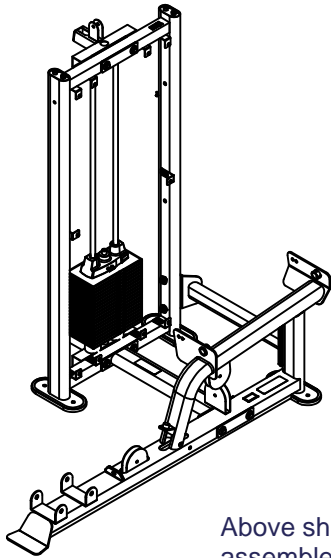

Above shows STEP 2 assembled and completed

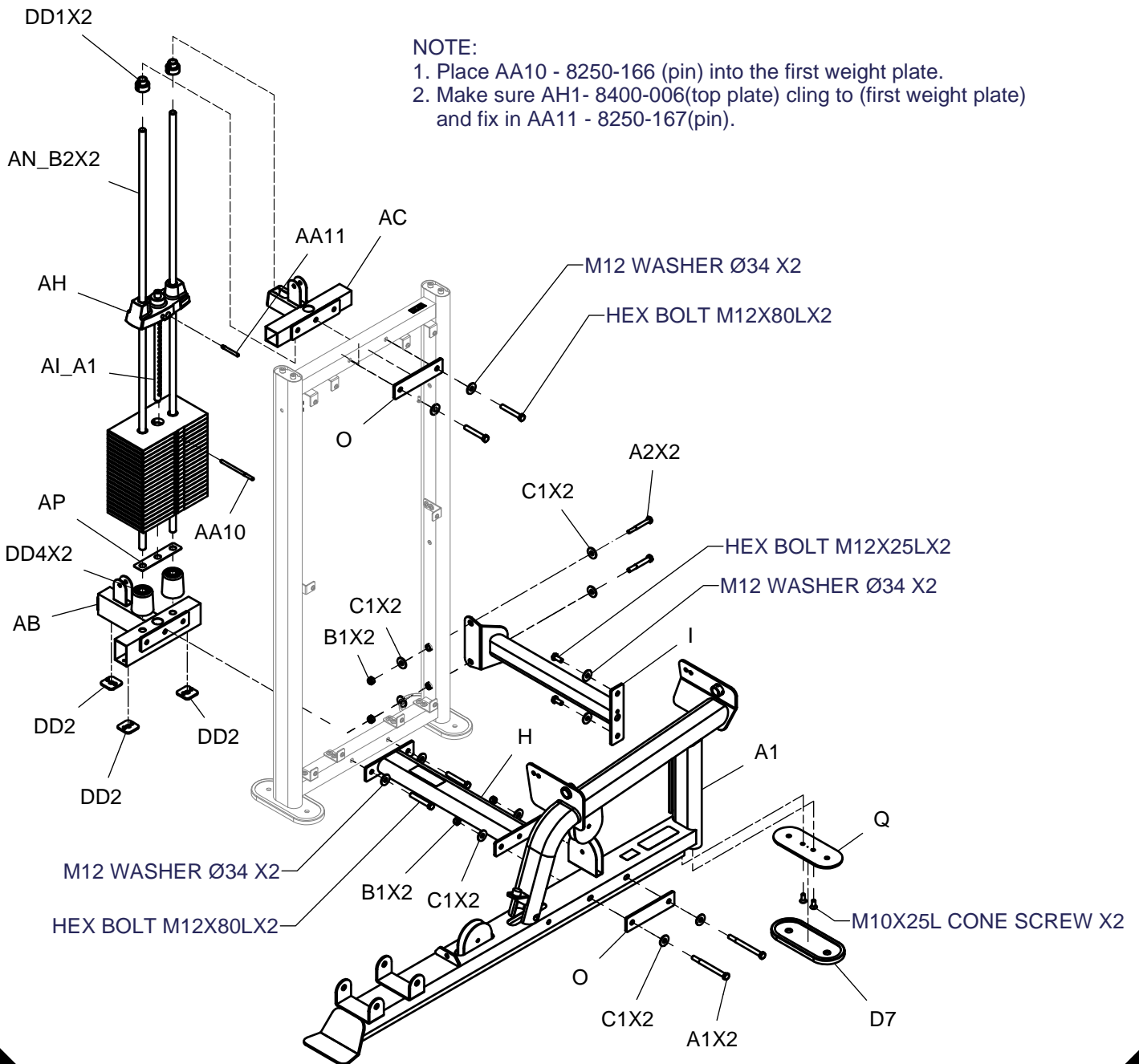

NOTE:

1. Place AA10 - 8250-166 (pin) into the first weight plate.
2. Make sure AH1- 8400-006(top plate) cling to (first weight plate) and fix in AA11 - 8250-167(pin).

HLP500 ASSEMBLY INSTRUCTIONS

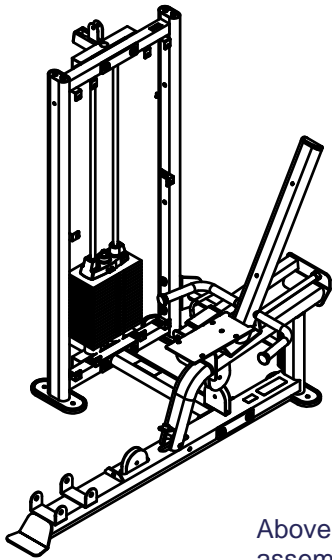

Above shows STEP 3 assembled and completed

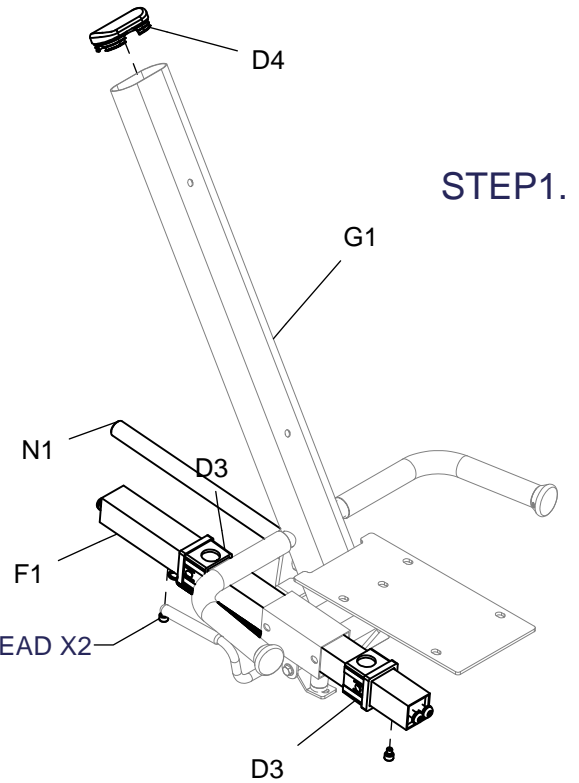

STEP 1.

STEP 2.

M8X10L ROUND INNER HEAD X2

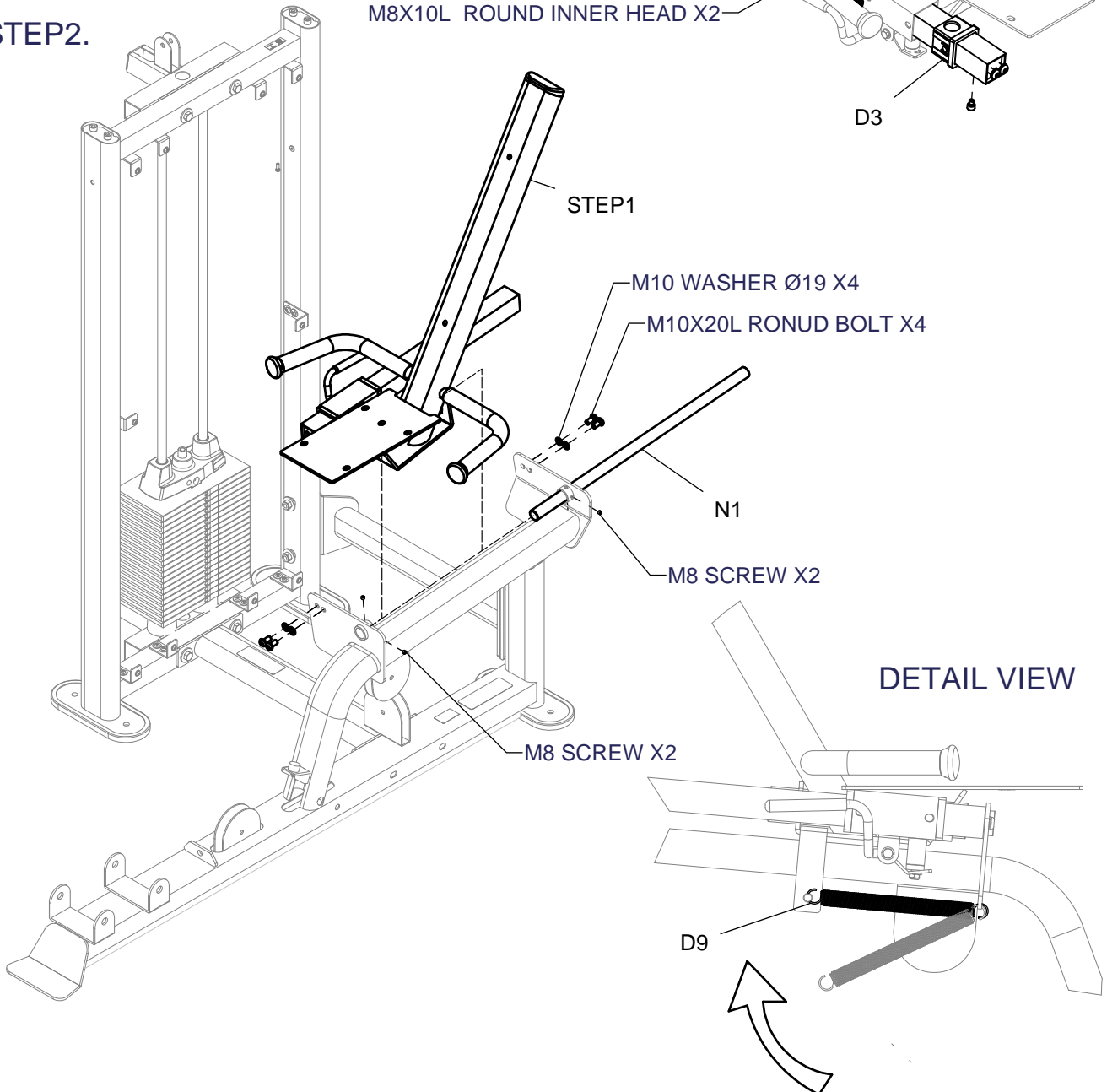

HLP500 ASSEMBLY INSTRUCTIONS

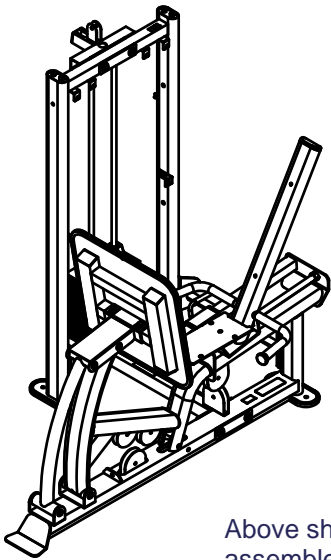

Above shows STEP 4 assembled and completed

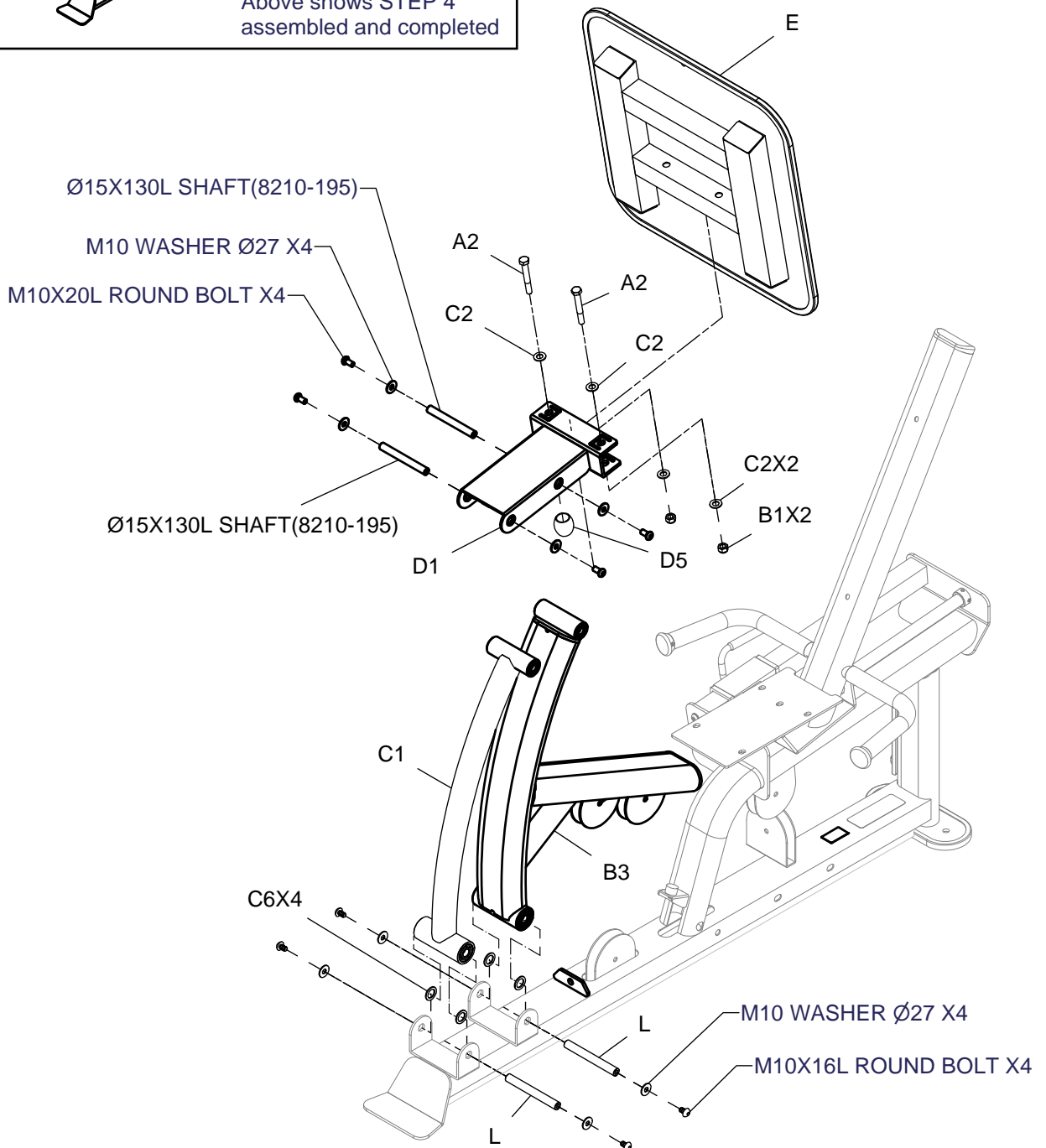

HLP500 ASSEMBLY INSTRUCTIONS

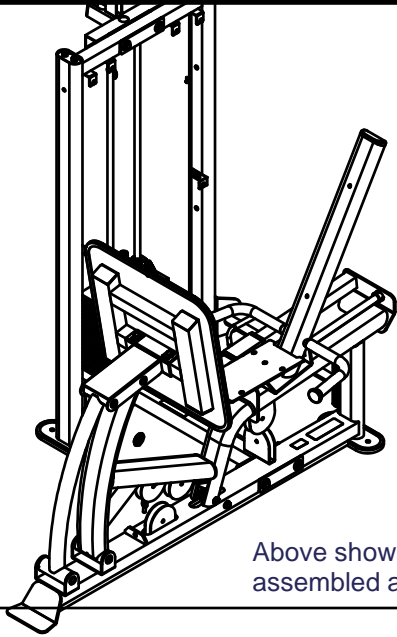

Above shows STEP 5
assembled and completed

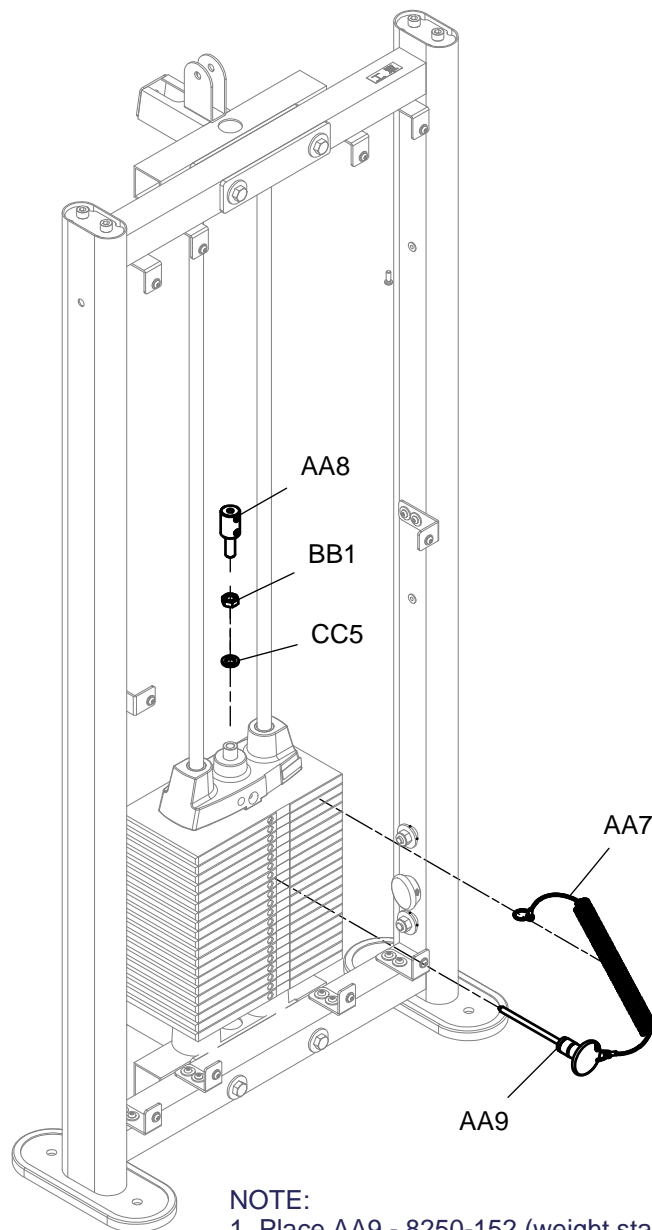

NOTE:

1. Place AA9 - 8250-152 (weight stack pin) into the the hole 20th of the weight stack.
2. Finally remove AA9 - 8250-152 (weight stack pin) and use as usual.

HLP500 ASSEMBLY INSTRUCTIONS

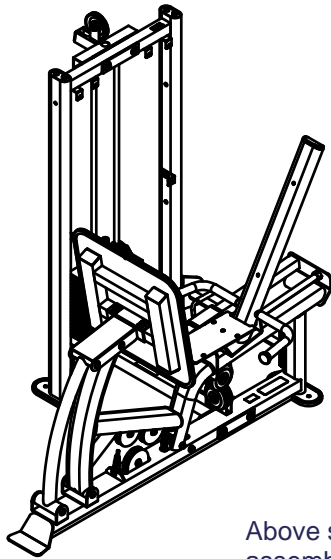

Above shows STEP 6 assembled and completed

STEP 1.

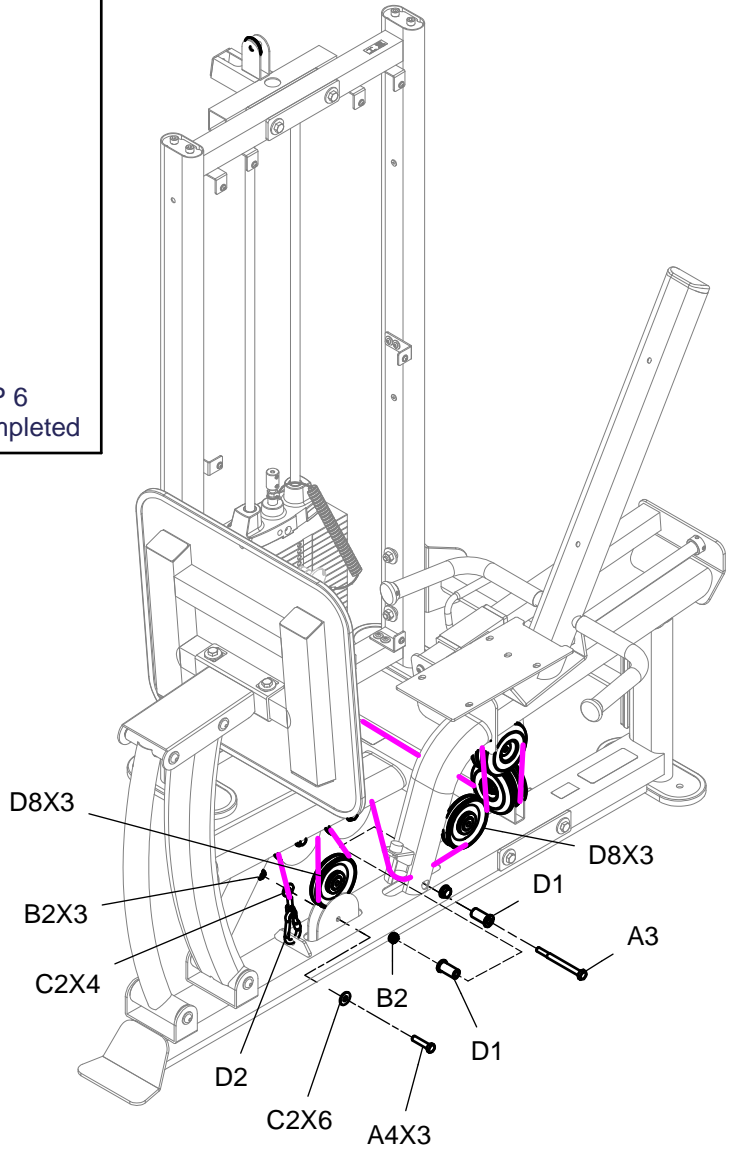

STEP 2.

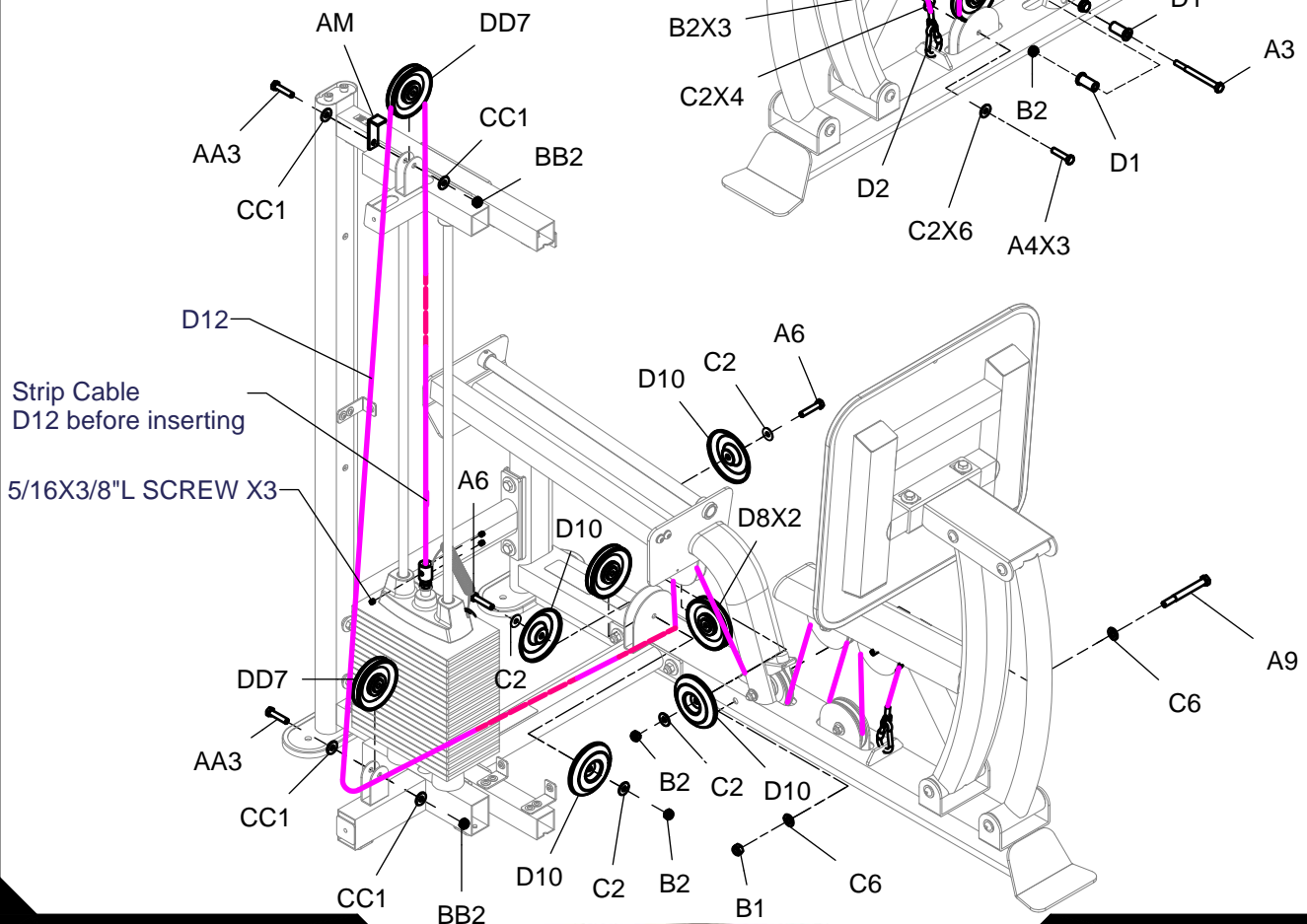

HLP500 ASSEMBLY INSTRUCTIONS

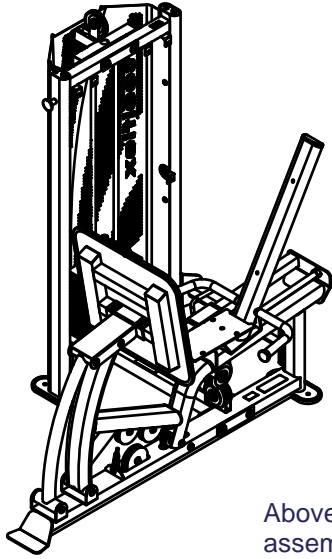

Above shows STEP 7
assembled and completed

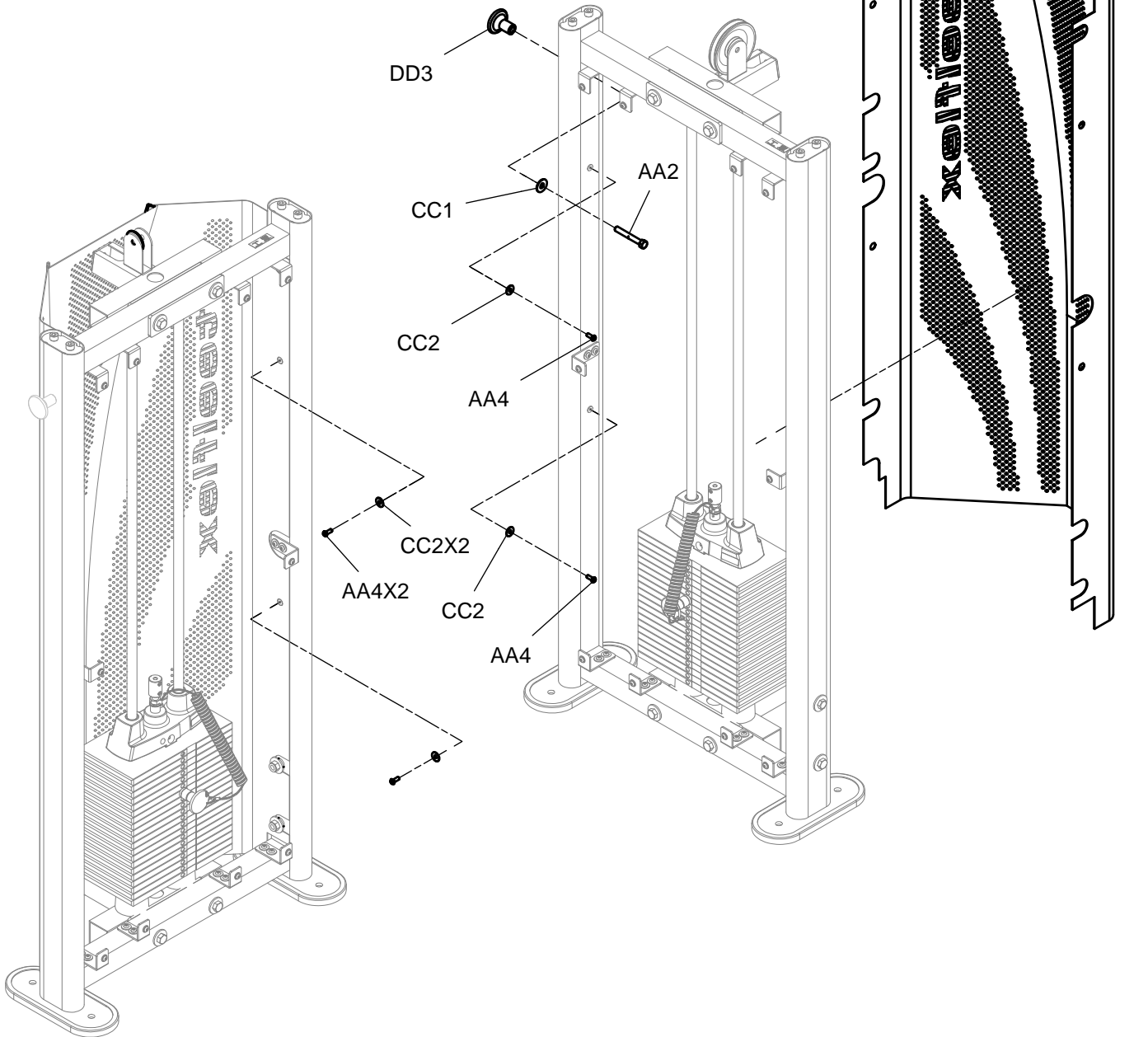

HLP500 ASSEMBLY INSTRUCTIONS

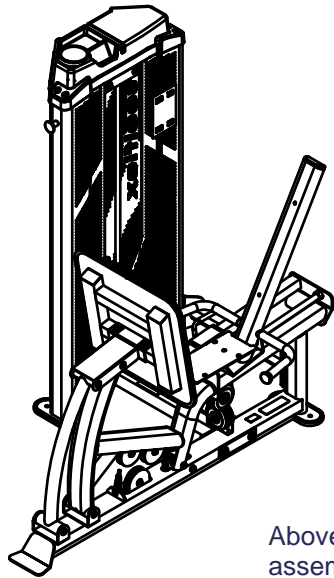

STEP 1.

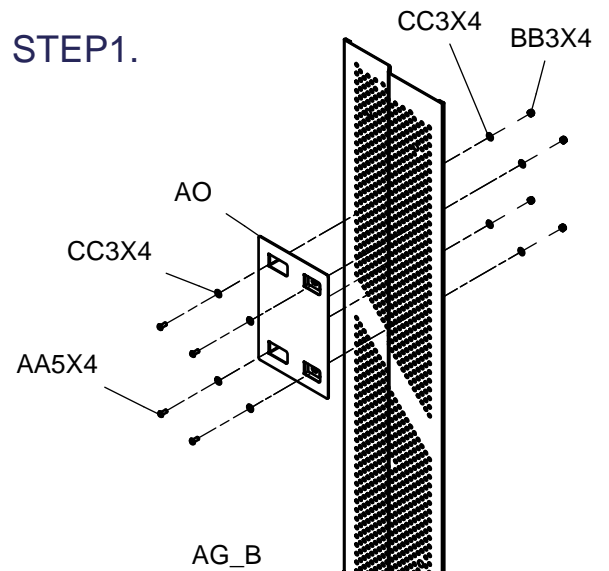

STEP 2.

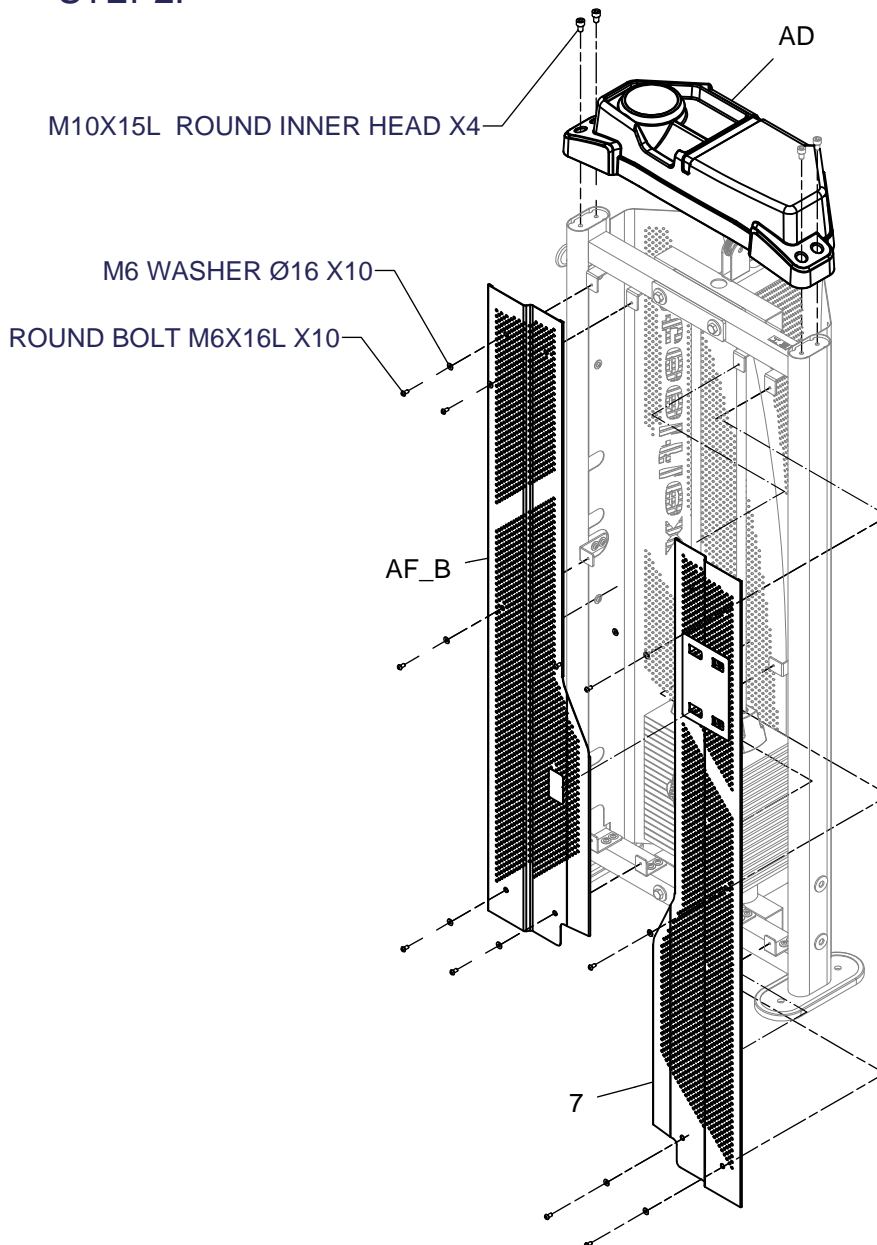

HLP500 ASSEMBLY INSTRUCTIONS

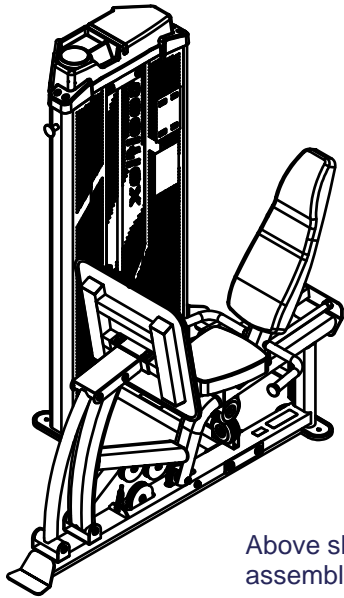

Above shows STEP 9
assembled and completed

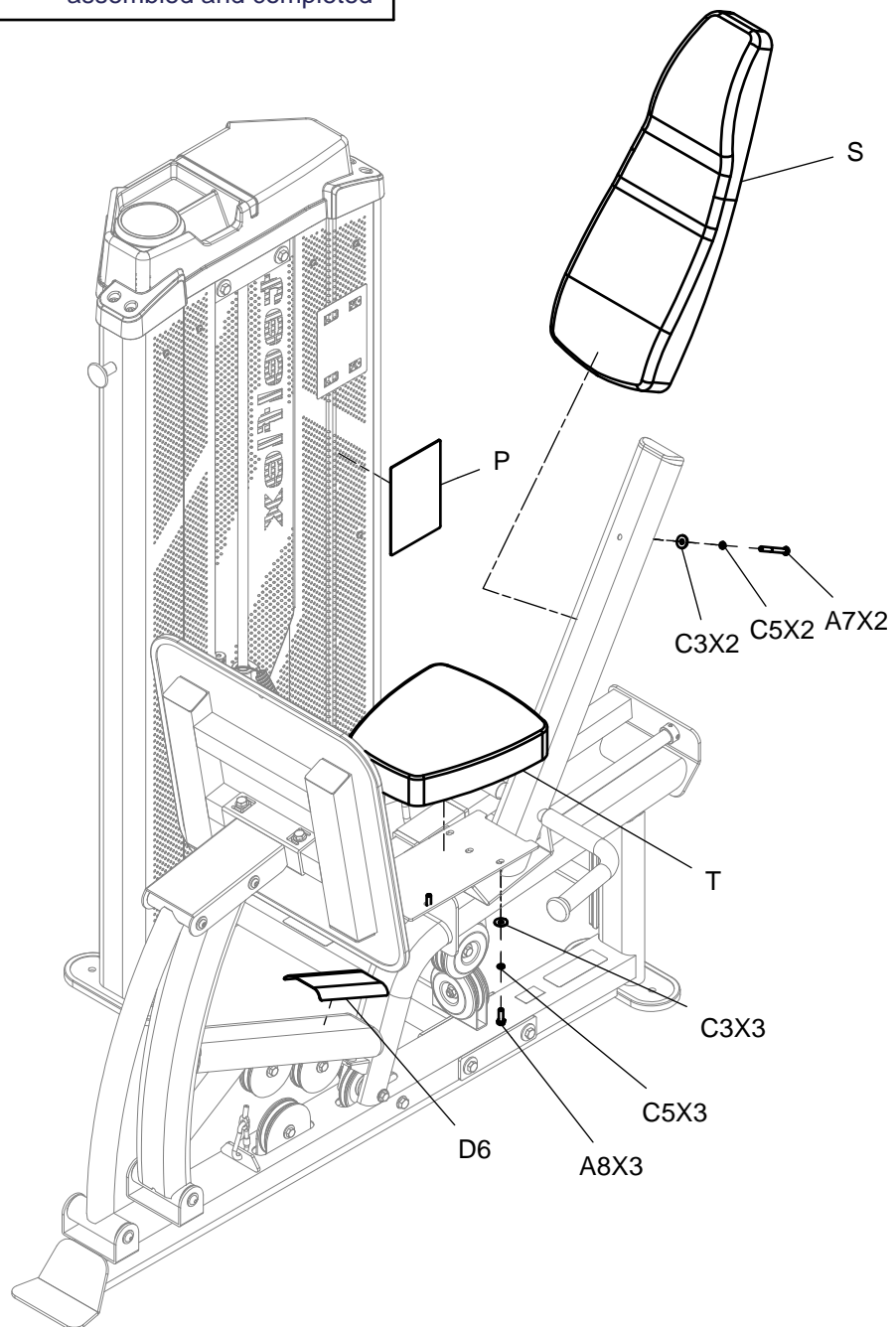

HOPE ASSEMBLY INSTRUCTIONS

DECAL REFERENCE

MAINTENANCE SCHEDULE		D	A	I	L	L	Y
Check the function and integrity of the following components. As noted, inspect equipment before each workout. Replace all damaged, broken or worn components immediately.							
Cables:	Check tension, end fittings, and coating	✓					
	Check that locking nut at weight stack is tight		✓				
Upholstery:	Wipe down and dry	✓					
	Clean and condition		✓				
Frame:	Wipe down and dry	✓					
	Polish / Wax		✓				
Chrome:	Wipe down and dry	✓					
	Polish / Lubricate		✓				
Nut / Bolts / Fasteners:	Tighten and / or adjust as needed	✓					
Guide Rods:	Lubricate and clean	✓					
Linear Rods:	Lubricate and clean	✓					
Seat Sleeves:	Lubricate and clean	✓					
Adjustments / Locking Pins / Tightening Knobs		✓					
Weight Stack Pins		✓					
Warning Instruction Labels		✓					
Springs / Pop Pins		✓					
Anti Skid Surfaces		✓					
Hand Grips / Rollers		✓					

For Steelflex Customer Service
Call +886 2 27209980

9440-258

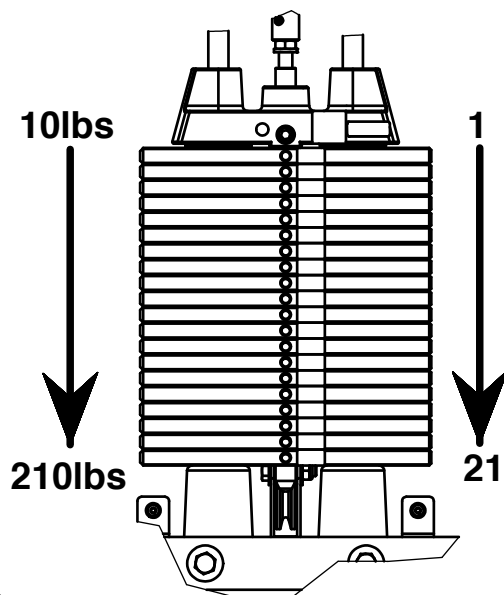

HOPE-042014

THERE IS A RISK ASSUMED BY INDIVIDUALS WHO USE THIS TYPE OF EQUIPMENT. TO MINIMIZE RISK, YOU MUST FOLLOW THESE RULES:

1. Inspect equipment before each workout. Check that all nuts, bolts, screws and pop pins are in place and fully tightened. Also, before use, check cables for signs of wear. Replace all worn parts immediately. Never use machine if any parts are damaged or missing. **FAILURE TO FOLLOW THESE RULES MAY RESULT IN SERIOUS INJURY.**
2. Keep clear of the cables and all moving parts when the machine is in use.
3. Always make sure all Snap Links are closed when doing any cable/pulley/strap exercises.
4. Exercise with care. Perform your exercises at a smooth moderate pace; never perform jerky or uncoordinated movements that may cause injury.
5. It is recommended that you should workout with a training partner.
6. Do not allow children or minors to play on or around this equipment.
7. If unsure of proper use of equipment, call Steelflex Customer Service +886 2 27209980.
8. **WARNING:** Consult your physician before starting your exercise program. For your own safety, do not begin any exercise program without proper instruction.

9440-259



9440-047

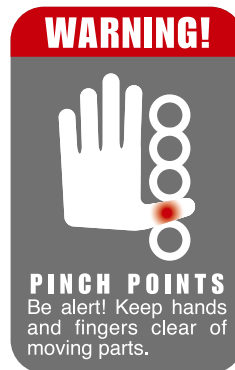

9440-117