

# HOPE

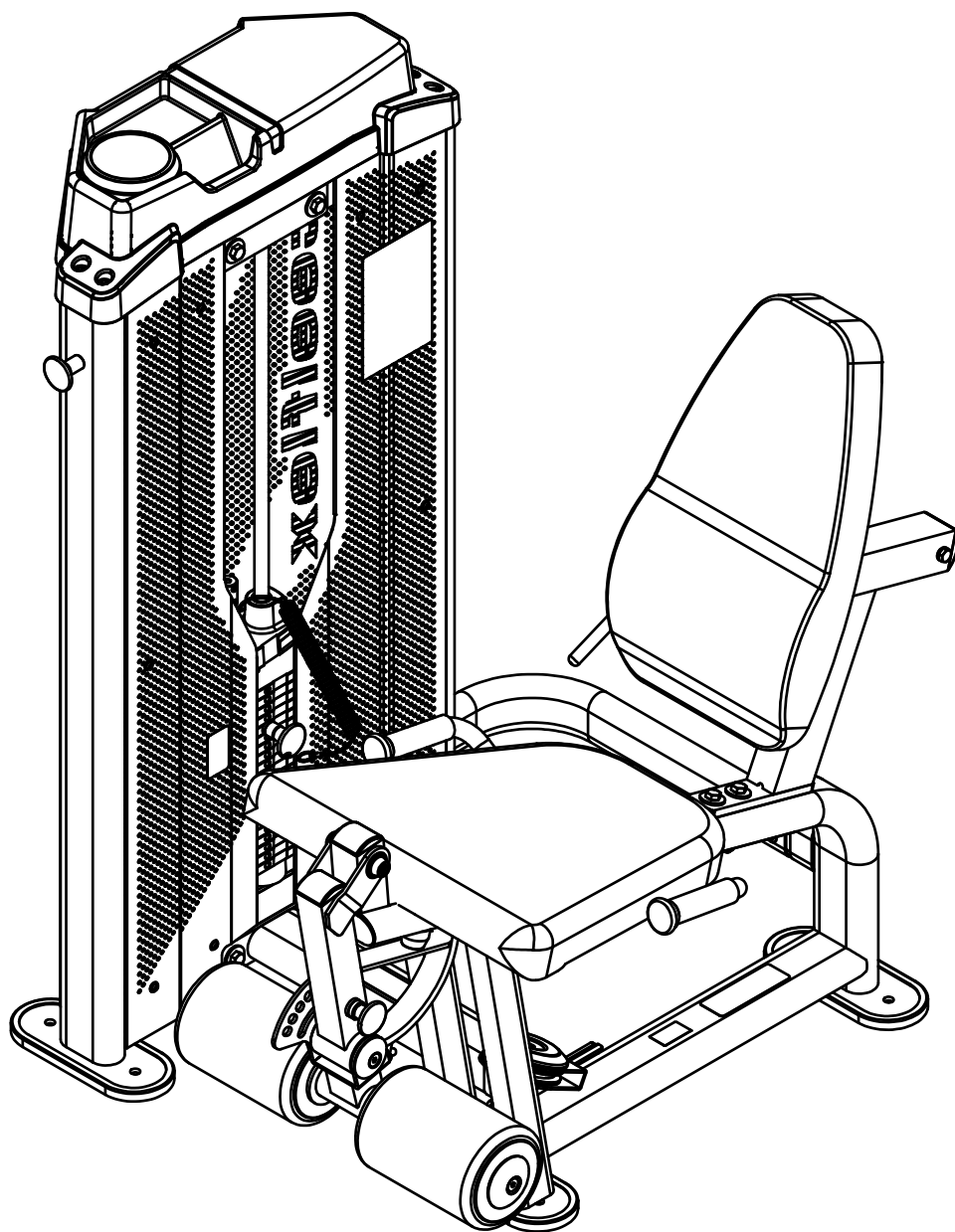

**Steelflex**

JOONG CHENN INDUSTRY CO., LTD.

Sales Office:

3F28, No.5, Shin-Yi Rd., Sec. 5, Taipei, Taiwan 110 R.O.C.

Tel: 886-2-27209980

Fax: 886-2-27229750

[www.steelflexfitness.com](http://www.steelflexfitness.com)

## HLE-200.4 OWNER'S MANUAL

# HLE200 ASSEMBLY INSTRUCTIONS

## HARDWARE ILLUSTRATION

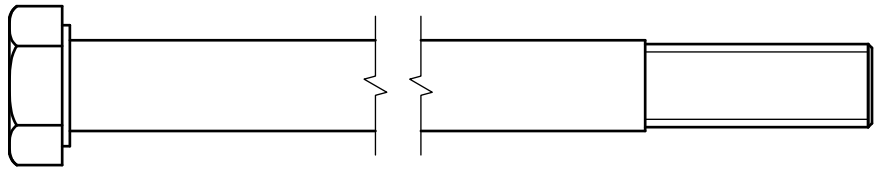
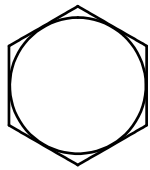

(A1)HEX BOLT M12X135L PARTIAL THREAD QTY.2

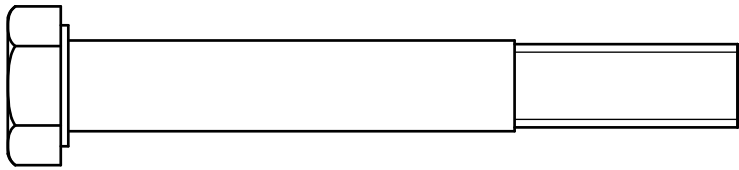
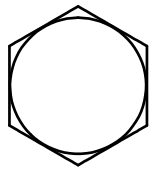

(A2)HEX BOLT M12X90L PARTIAL THREAD QTY.2

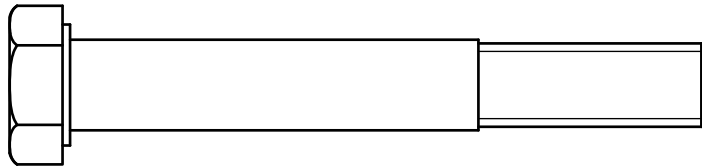
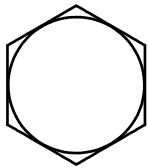

(A3)HEX BOLT M12X85L PARTIAL THREAD QTY.2

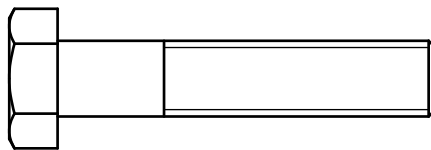
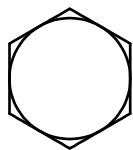

(A4)HEX BOLT M10X50L PARTIAL THREAD QTY.1

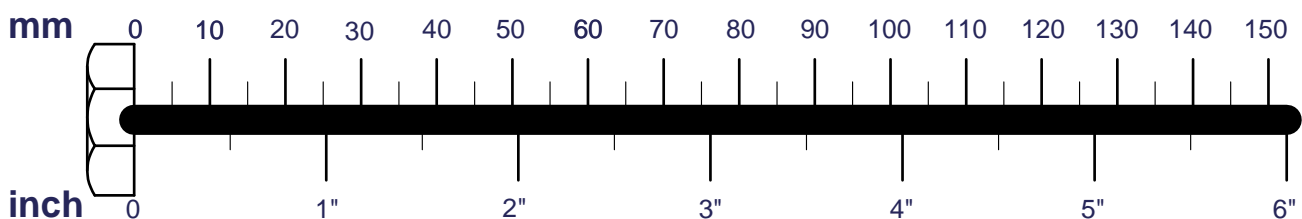

# HLE200 ASSEMBLY INSTRUCTIONS

## HARDWARE ILLUSTRATION

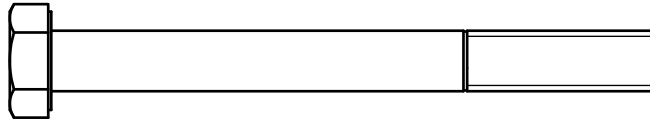
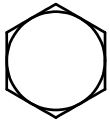

(A6)HEX BOLT M8X80L PARTIAL THREAD QTY.1

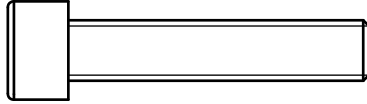

(A7)ROUND ALLEN HAED M8X40L PARTIAL QTY.1

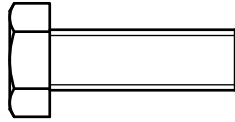
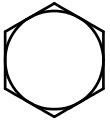

(A8)HEX BOLT M8X25L PARTIAL QTY.2

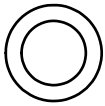

(A9)STEEL BUSHING Ø12XØ8.5XØ21.5 QTY.1

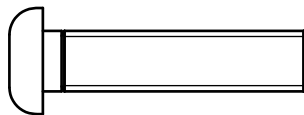
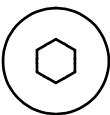

(A11)ROUND INNER HEX SCREW M8X35L PARTIAL THREAD QTY.4

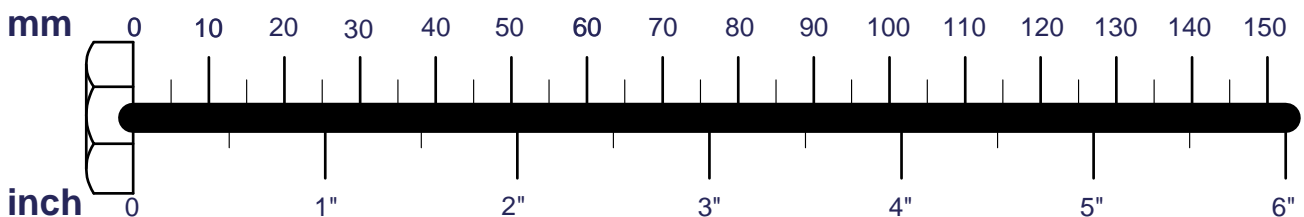

# HLE200 ASSEMBLY INSTRUCTIONS

## HARDWARE ILLUSTRATION

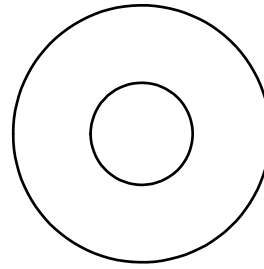
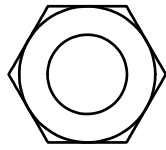

(B1)NYLON LOCK NUT M12 QTY.8

(C1)M12(I.D.)FLAT WASHER Ø34 QTY.12

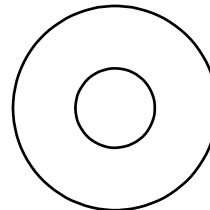
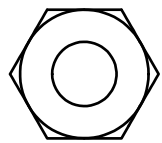

(B2)NYLON LOCK NUT M10 QTY.1

(C2)M10(I.D.)FLAT WASHER Ø27 QTY.2

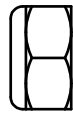
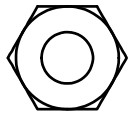

(B3)NYLON LOCK NUT M8 QTY.1

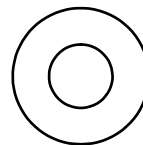

(C4)M8(I.D.)FLAT WASHER Ø18 QTY.2

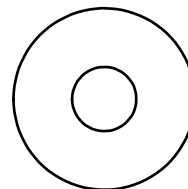

(C5)M8(I.D.)FLAT WASHER Ø24 QTY.7

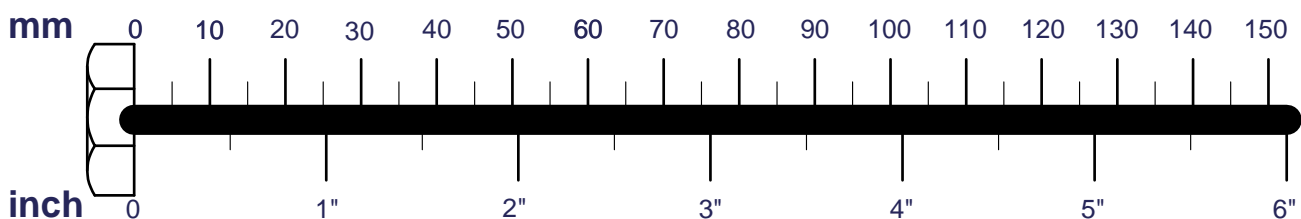

# HLE200 ASSEMBLY INSTRUCTIONS

## HARDWARE ILLUSTRATION

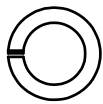

(C7)SPRING WASHER M8 QTY.7

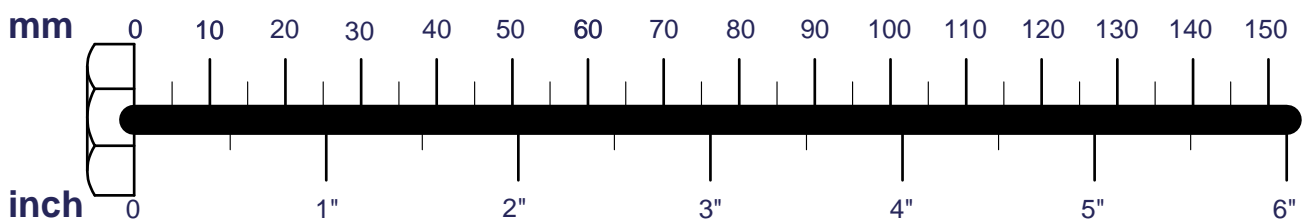

# HLE200 ASSEMBLY INSTRUCTIONS

## FRAME HARDWARE ILLUSTRATION

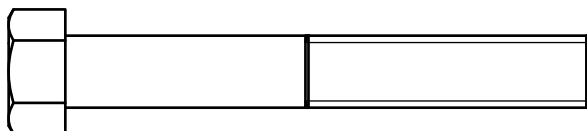
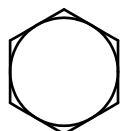

(AA2)HEX BOLT 3/8"X2-3/4"L PARTIAL THREAD QTY.1

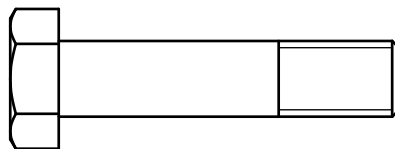
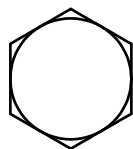

(AA3)HEX BOLT M10X45L PARTIAL THREAD QTY.2

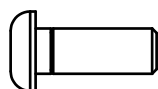

(AA4)ROUND INNER HEX SCREW M6x16L PARTIAL THREAD QTY.24

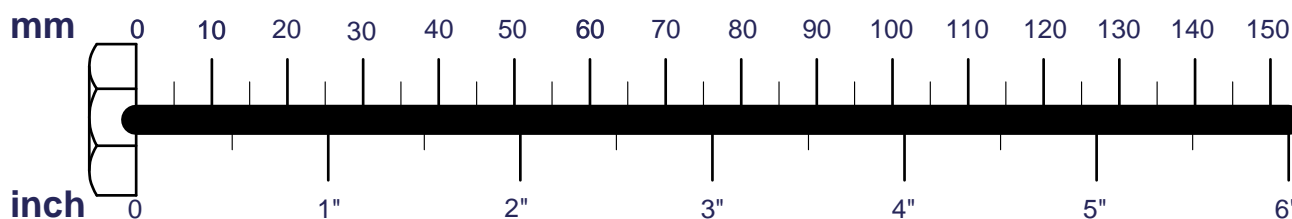

# HLE200 ASSEMBLY INSTRUCTIONS

## FRAME HARDWARE ILLUSTRATION

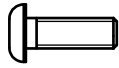

(AA5)ROUND INNER HEX SCREW M4x12L PARTIAL THREAD QTY.4

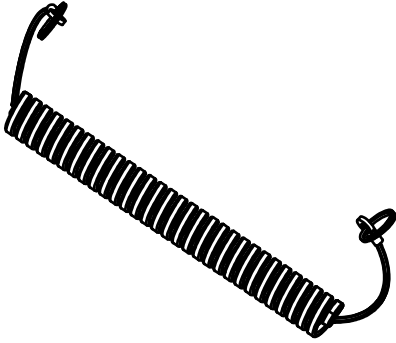

(AA7)ELASTIC BELT QTY.1

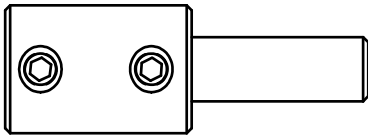

(AA8)RT3(8260-009) QTY.1

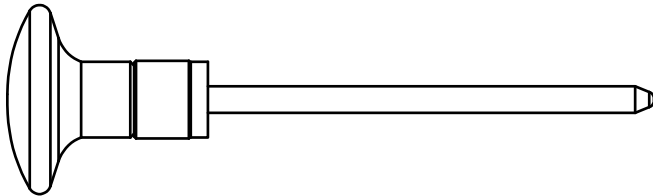

(AA9)20LB PIN(8250-152) QTY.1

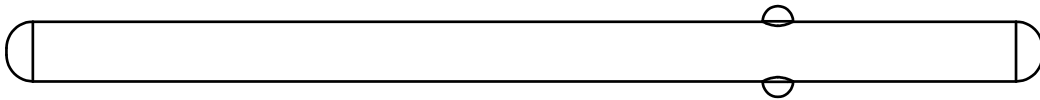

(AA10)Ø5/16" FIXED PIN (8250-166) QTY.1

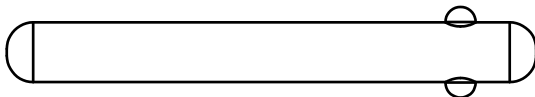

(AA11)Ø5/16" FIXED PIN (8250-167) QTY.1

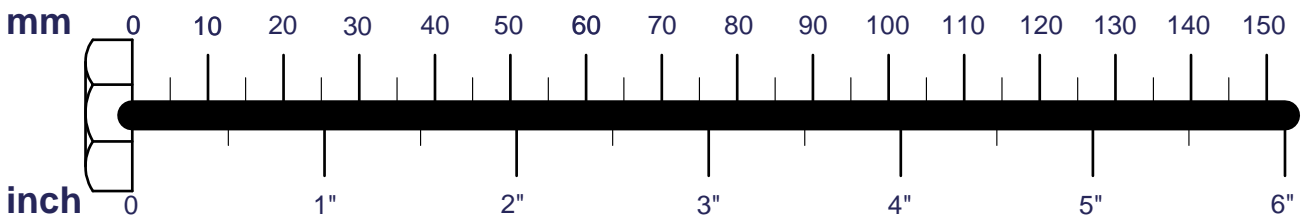

# HLE200 ASSEMBLY INSTRUCTIONS

## HARDWARE ILLUSTRATION

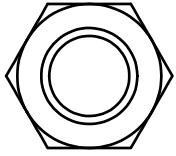

(BB1)1/2"NUT-13UNC QTY.1



(CC1)M10(I.D.)FLAT WASHER Ø27 QTY.5

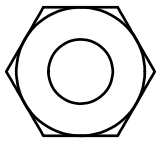
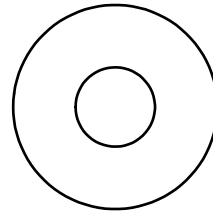

(BB2)NYLON LOCK NUT M10 QTY.2

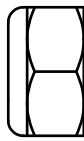

(CC2)M6(I.D.)FLAT WASHER Ø19 QTY.24

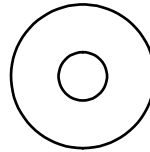

(BB3)NYLON LOCK NUT M4 QTY.4



(CC3)M4(I.D.)FLAT WASHER Ø10 QTY.8

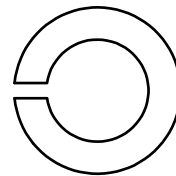

(CC5)SPRING WASHER 1/2" QTY.1

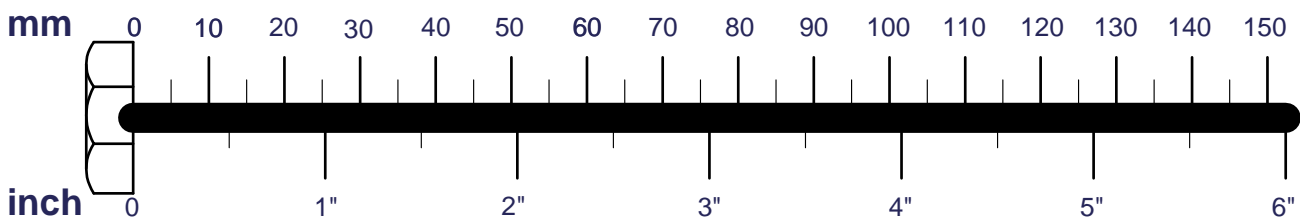
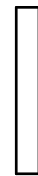

# HLE200 ASSEMBLY INSTRUCTIONS

## HARDWARE ILLUSTRATION

D1.Ø3/4XØ13.5X8L STEEL BUSHIING(8110-014)-----	[2PCS]
D2.Ø60 CAP COVER(8130-231)-----	[2PCS]
D3.Ø72 CAP COVER(8130-236)-----	[2PCS]
D4.Ø38XØ26X1.5t CU WSAHER(8520-008)-----	[2PCS]
D5.50X50X1.8t END CAP(9211-087)-----	[2PCS]
D6.60X60X2t END CAP(9211-092)-----	[1PCS]
D7.50X100X2.0tX30H END CAP(9211-114)-----	[1PCS]
D8.Ø116X17 CAP COVER(9211-173)-----	[1PCS]
D9.Ø120XØ52X3t NYLON WASHER(9214-039)-----	[2PCS]
D10.108X14.5tX263L RUBBER PAD(9310-075)-----	[2PCS]
D11.Ø110X22 PULLEY (9213-002B)-----	[1PCS]
D12.3400mm STEEL CABLE(FHLE200A1)-----	[1PCS]

D1.

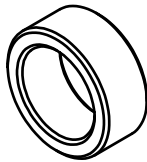

D2.



D3.

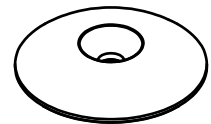

D4.

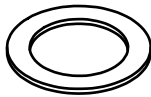

D5.

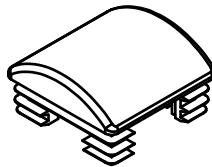

D6.

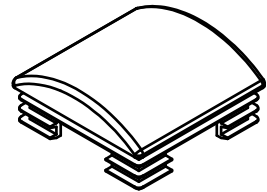

D7.

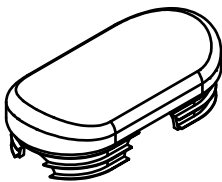

D8.

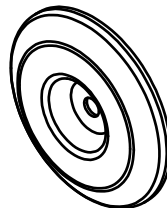

D9.

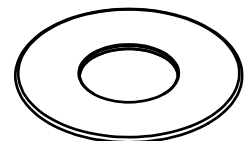

D10.

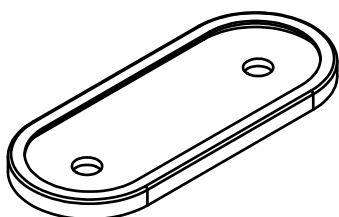

D11.



D12.

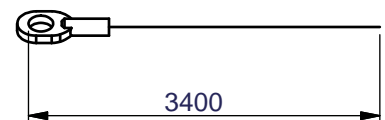

# HLE200 ASSEMBLY INSTRUCTIONS

## PARTS ILLUSTRATION SHEET

A1 [1SET]

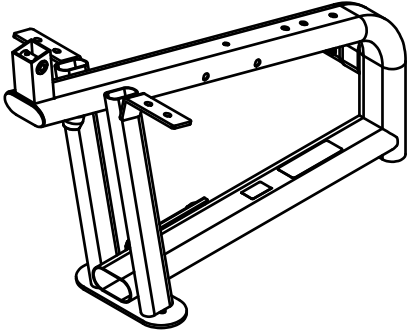

B1 [1SET]  
6690-006

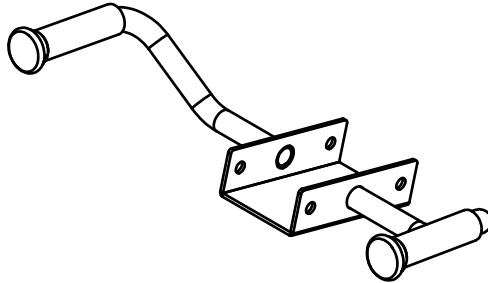

D [1SET]

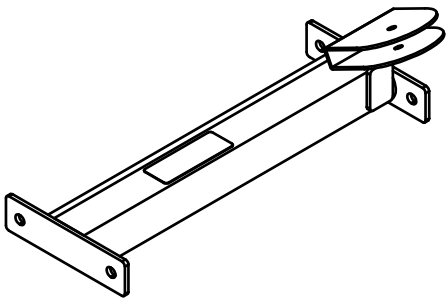

E [1SET]

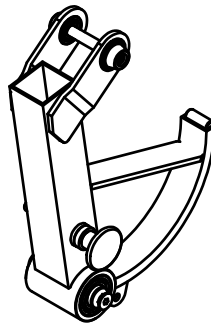

F [1SET]

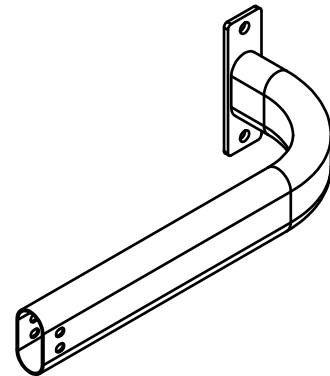

H [1SET]

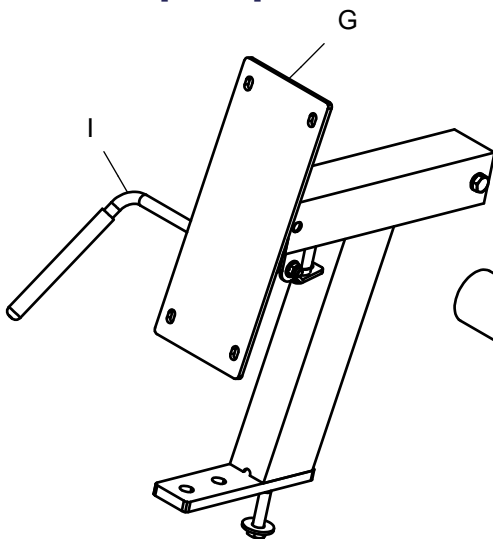

J [1SET]

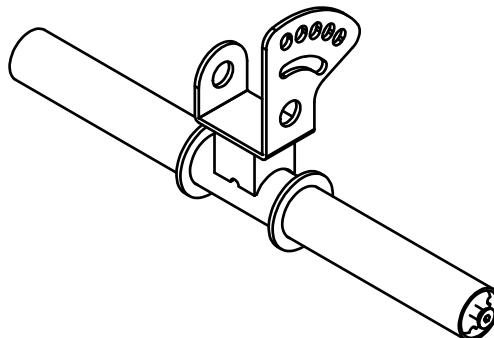

# HLE200 ASSEMBLY INSTRUCTIONS

## PARTS ILLUSTRATION SHEET

L [1PCS]  
8312-077

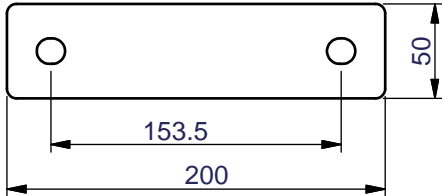

M [1PCS]  
8313-188

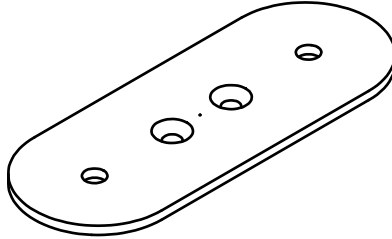

N [1SET]  
9121-091

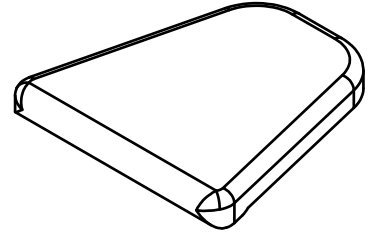

O [1SET]  
9111-087

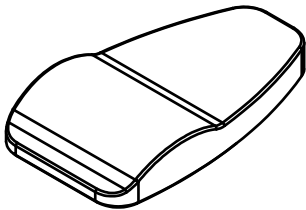

P1  
[2SET]  
9161-078

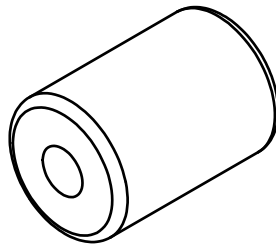

Q [1PCS]  
9420-078

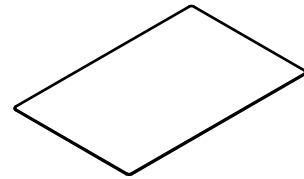

T [1PCS]  
8312-204

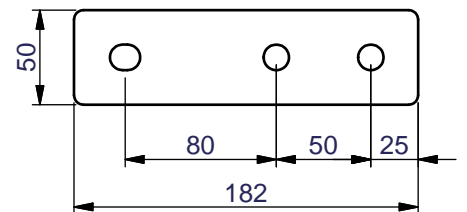

# HLE200 ASSEMBLY INSTRUCTIONS

## FARME PARTS ILLUSTRATION SHEET

AA1 [1SET]  
6610-019

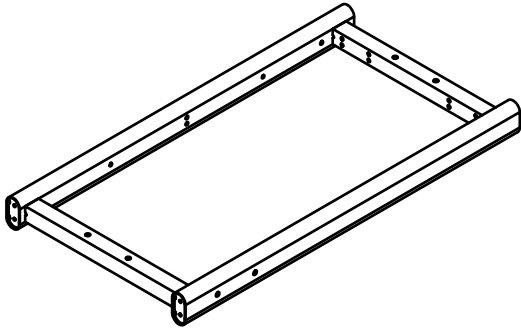

AB [1SET]  
6610-017

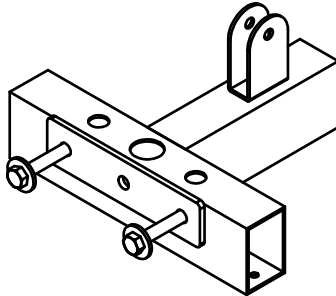

AC [1PCS]  
6610-018

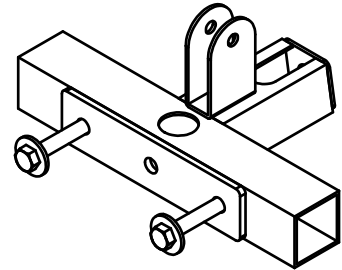

AD [1PCS]  
9211170-023

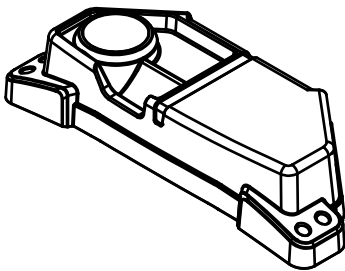

AE [1PCS]  
8380-066

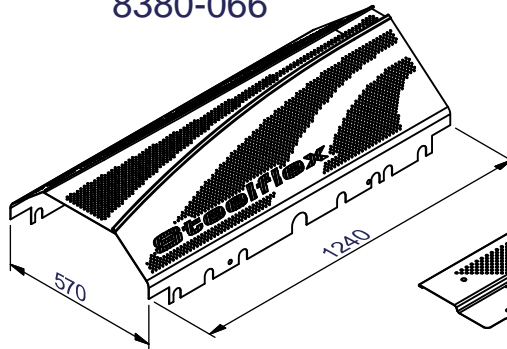

AF [1SET]  
8380-067

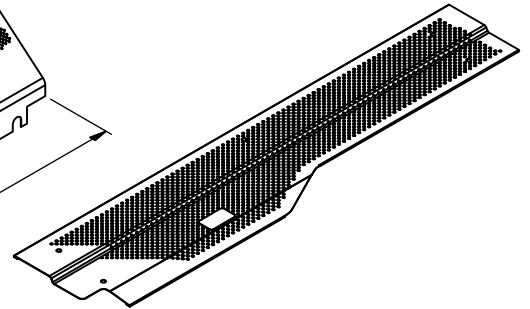

AG [1PCS]  
8380-068

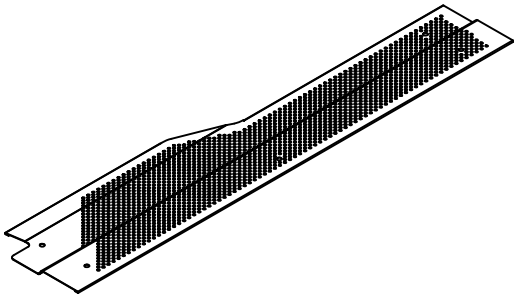

AH [1SET]  
8400-006

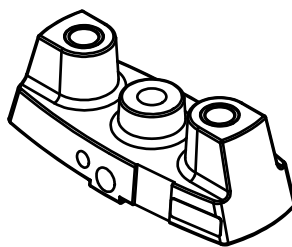

AI1 [1PCS]  
8210-191  
Ø3/4"X400L

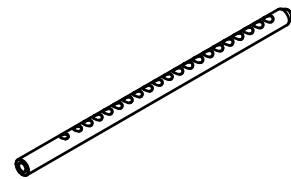

AJ[6SET]  
8331-064

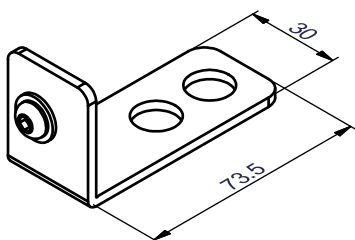

AK[4SET]  
8331-065

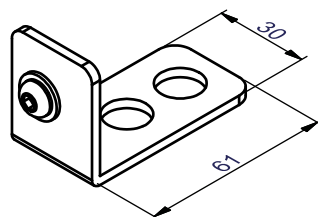

AL[2PCS]  
8313-188

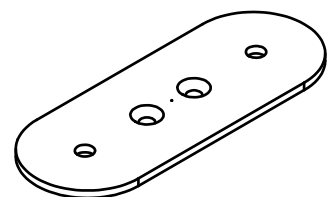

# HLE200 ASSEMBLY INSTRUCTIONS

## FARME PARTS ILLUSTRATION SHEET

AM [1PCS]  
8331-017

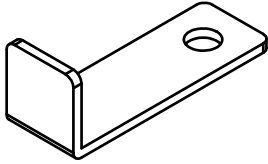

AN1 [2PCS]  
8280-036  
Ø3/4"X1222L

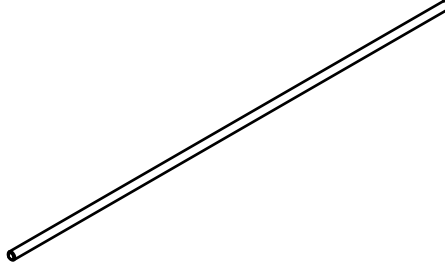

AO [1PCS]  
8345-014

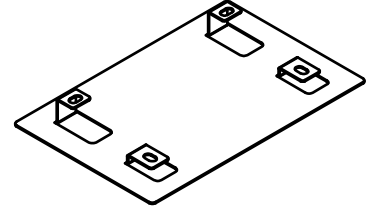

AP [1PCS]  
8311-194

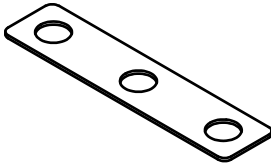

# HLE200 ASSEMBLY INSTRUCTIONS

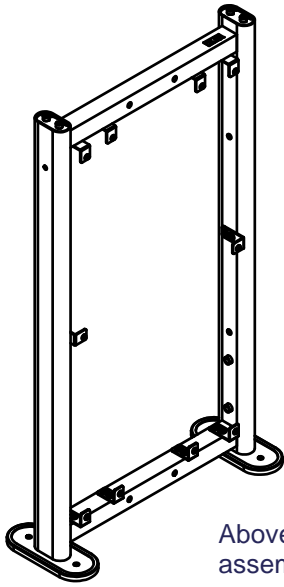

Above shows STEP 1  
assembled and completed

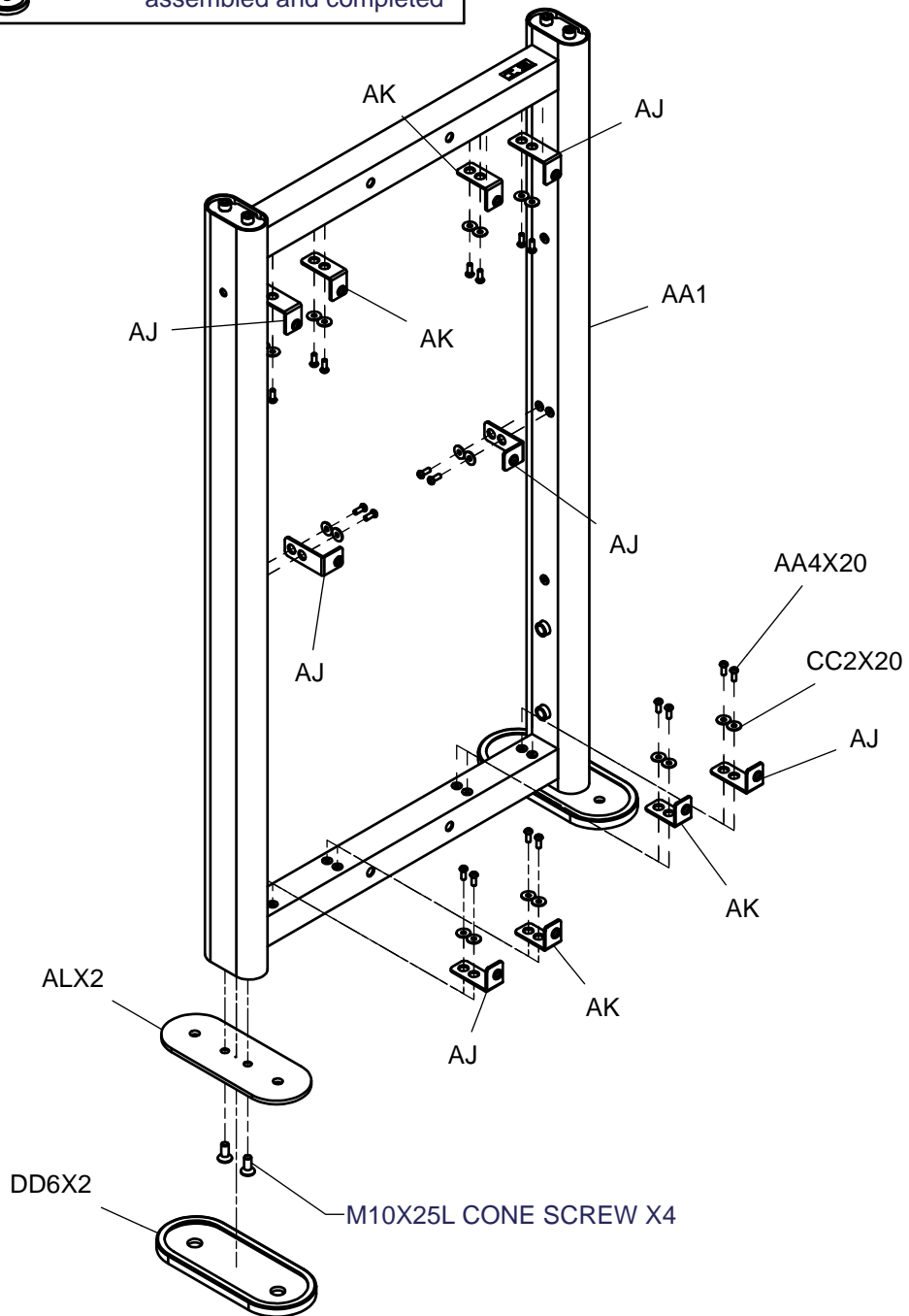

# HLE200 ASSEMBLY INSTRUCTIONS

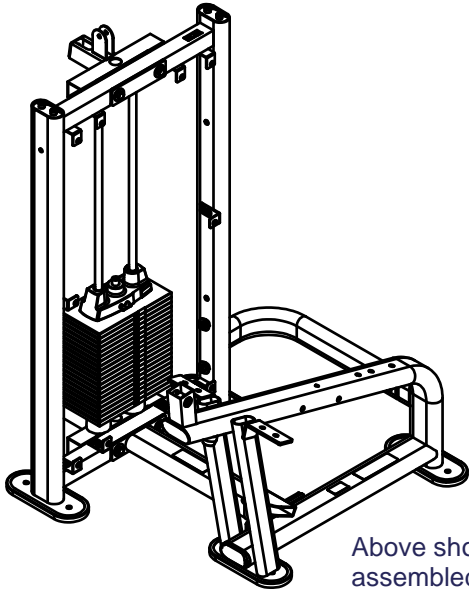

Above shows STEP 2 assembled and completed

**NOTE:**

1. Place AA10 - 8250-166 (pin) into the first weight plate.
2. Make sure AH1- 8400-006A(top plate) cling to (first weight plate) and fix in AA11 - 8250-167(pin).

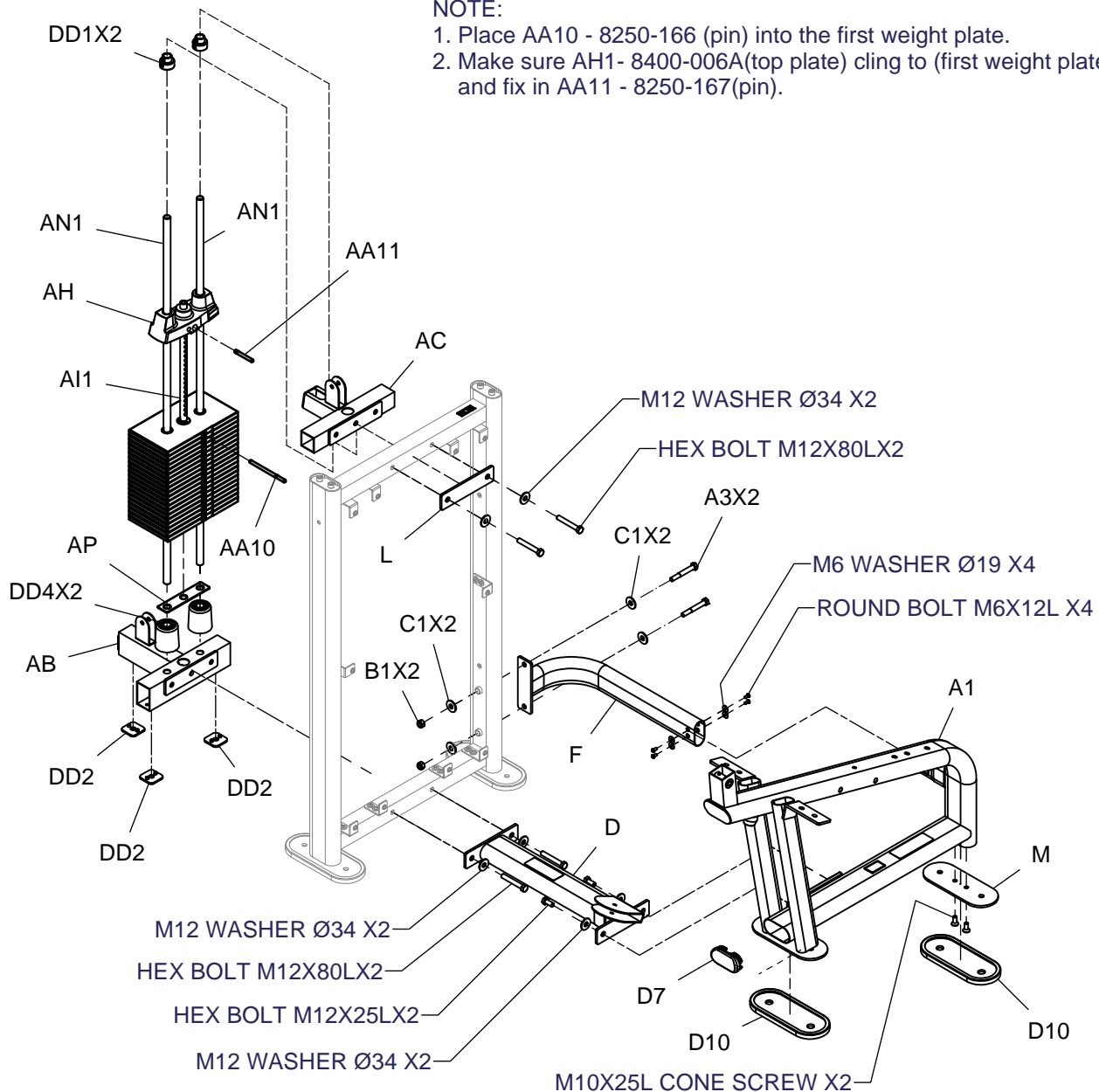

# HLE200 ASSEMBLY INSTRUCTIONS

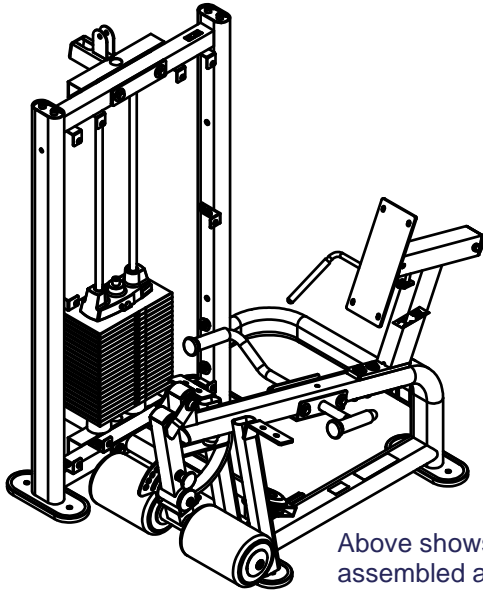

Above shows STEP 3 assembled and completed

## STEP1.

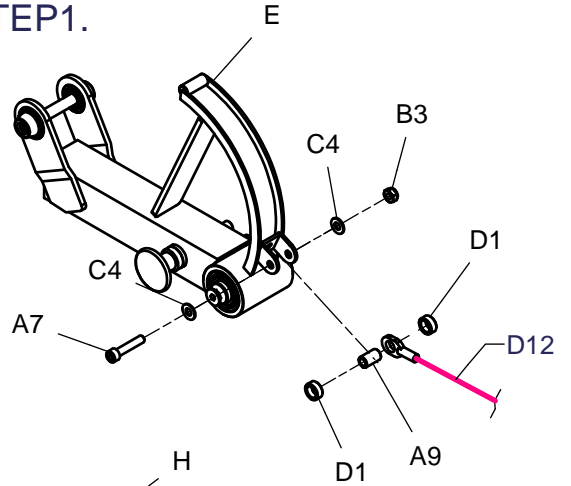

## STEP2.

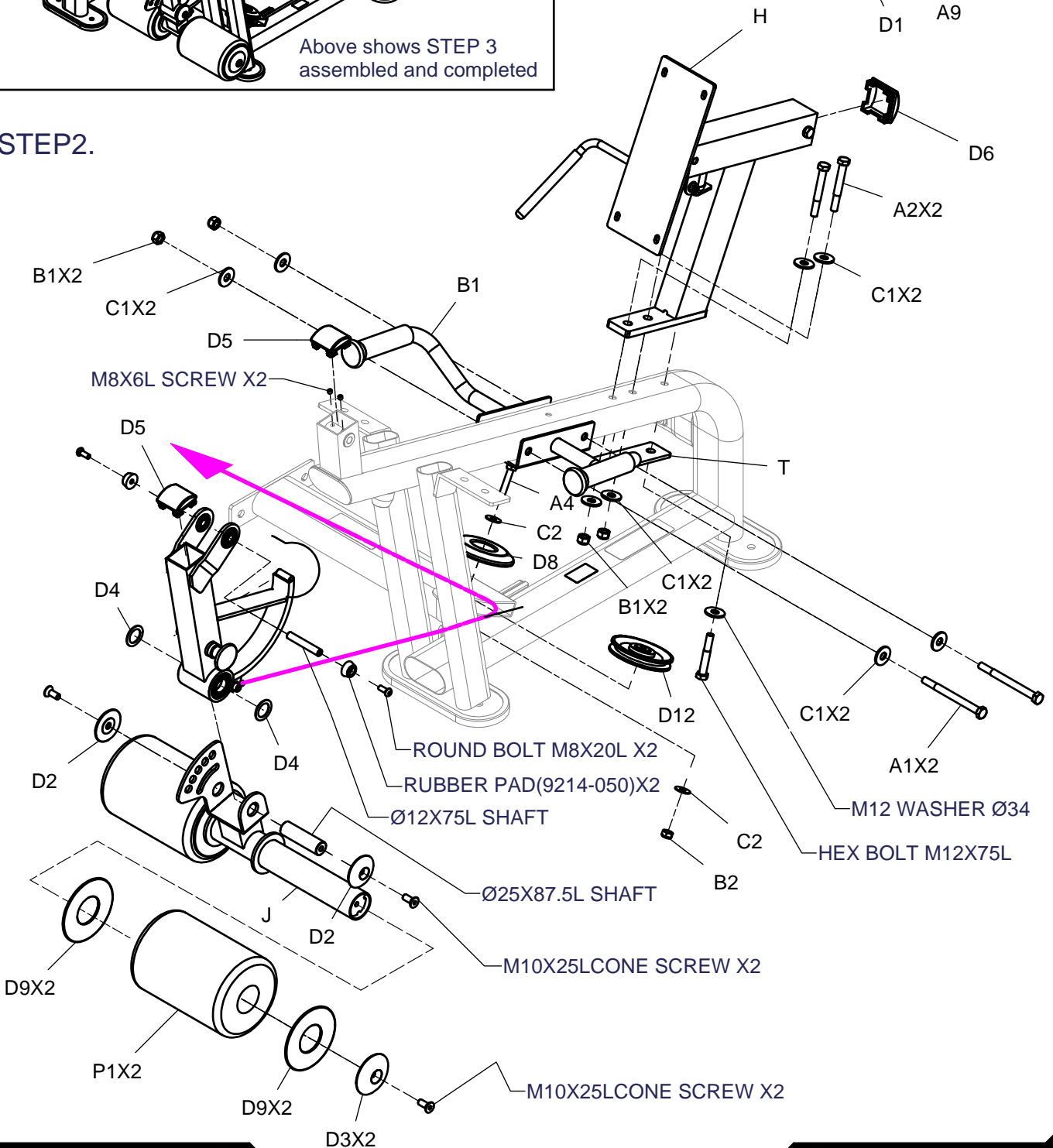

# HLE200 ASSEMBLY INSTRUCTIONS

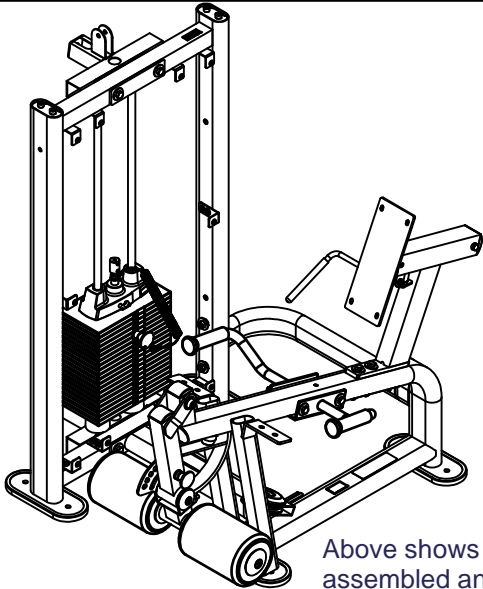

Above shows STEP 4  
assembled and completed

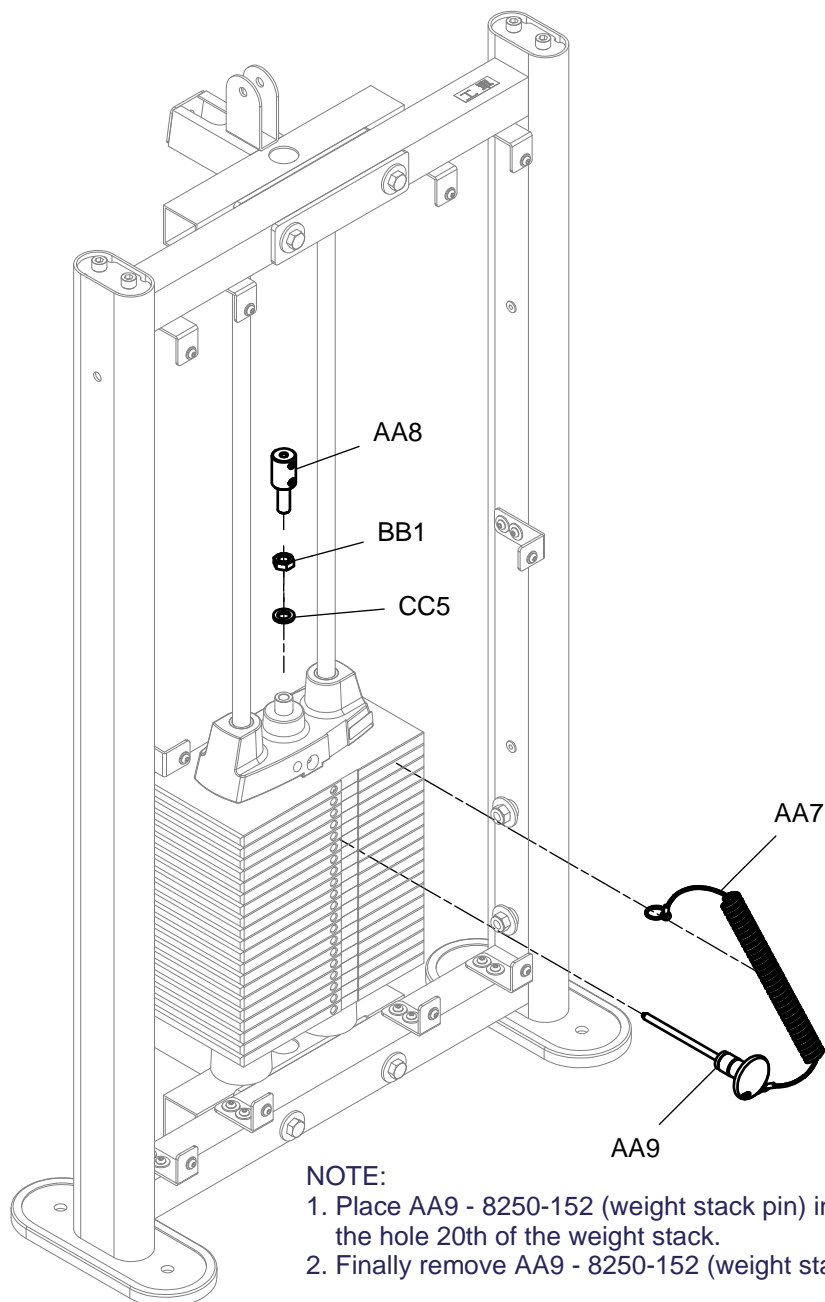

**NOTE:**

1. Place AA9 - 8250-152 (weight stack pin) into the hole 20th of the weight stack.
2. Finally remove AA9 - 8250-152 (weight stack pin) and use as usual.

# HLE200 ASSEMBLY INSTRUCTIONS

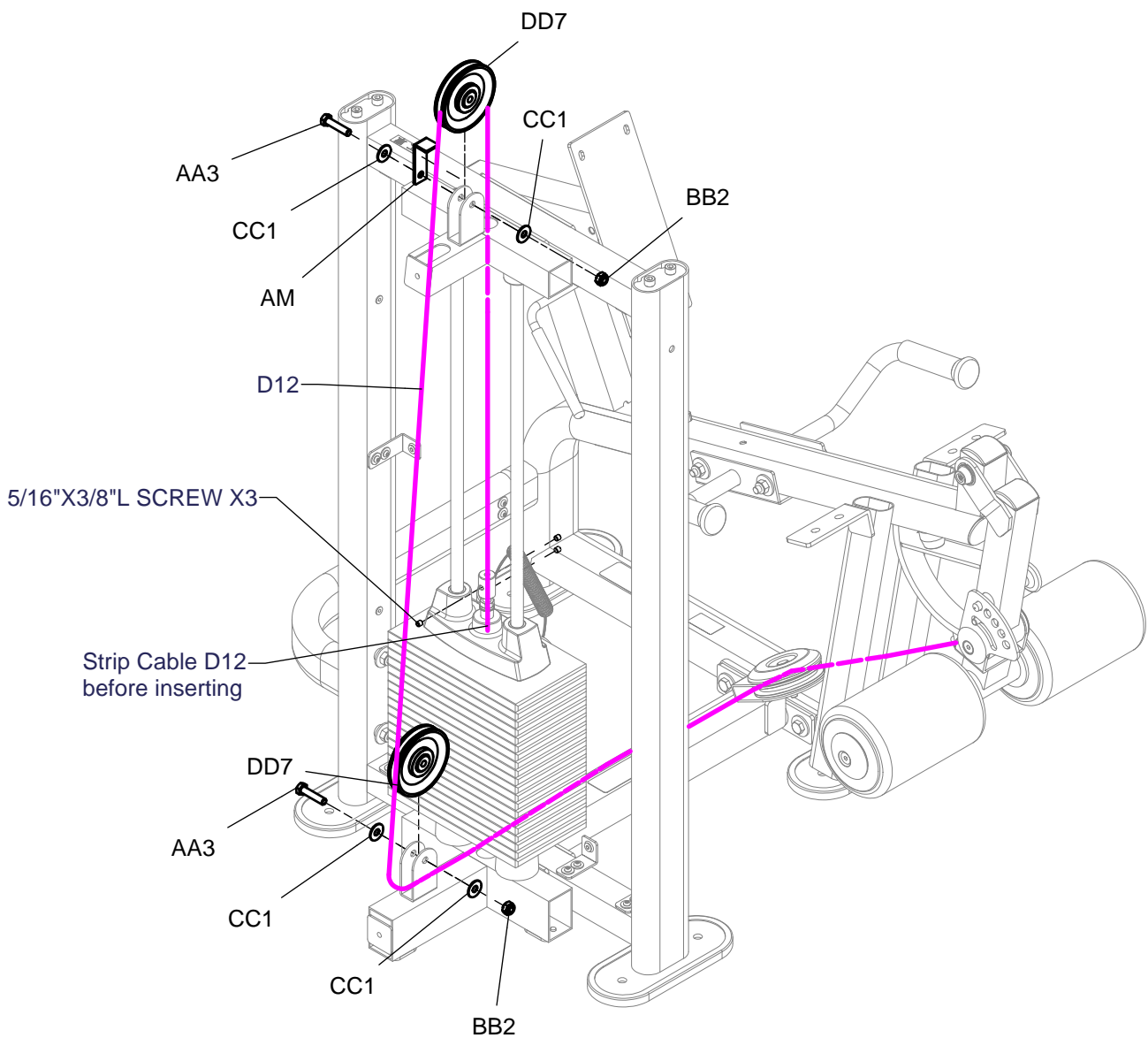
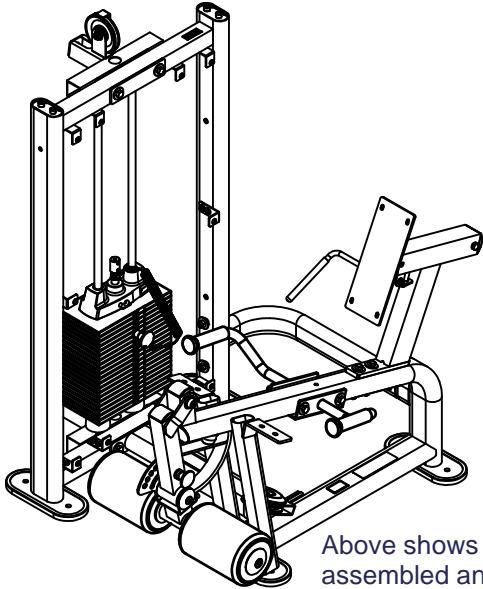

# HLE200 ASSEMBLY INSTRUCTIONS

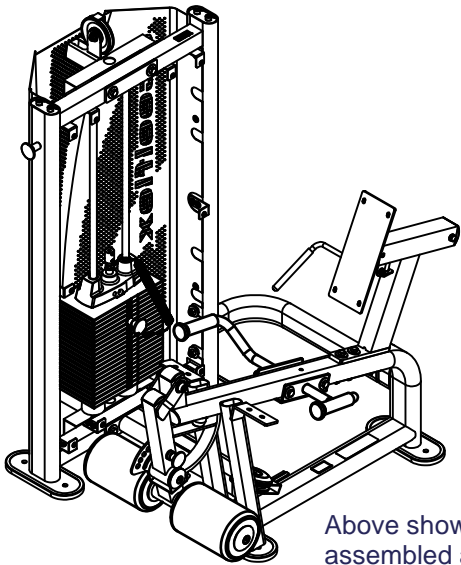

STEP 1.

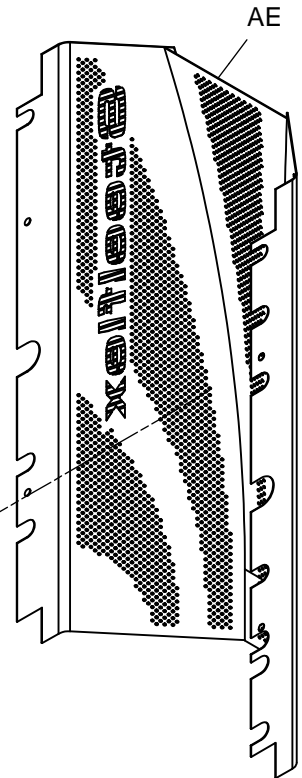

STEP 2.

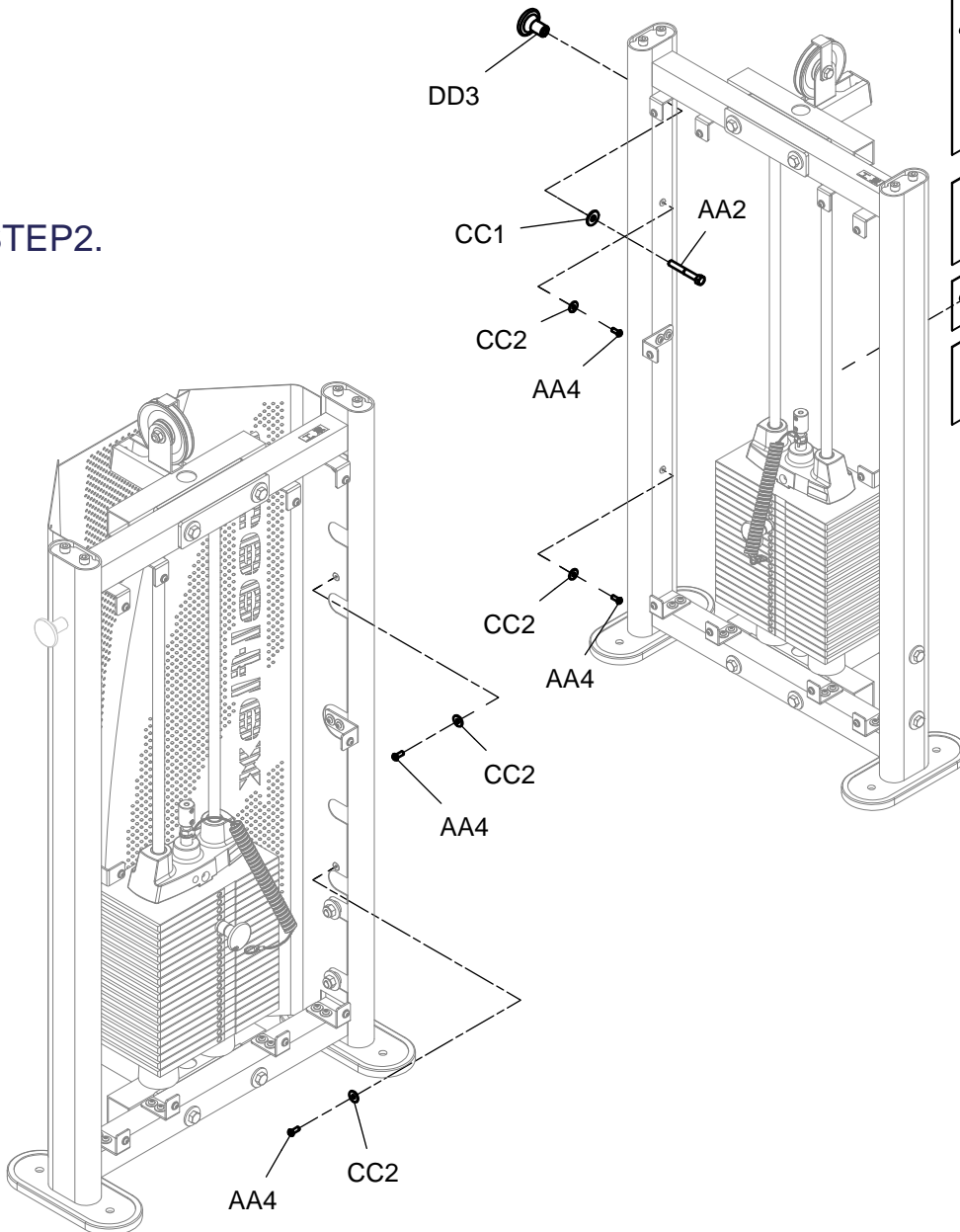

# HLE200 ASSEMBLY INSTRUCTIONS

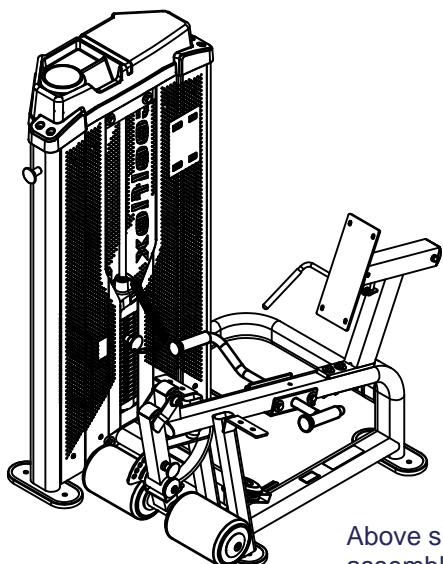

Above shows STEP 7 assembled and completed

## STEP.1

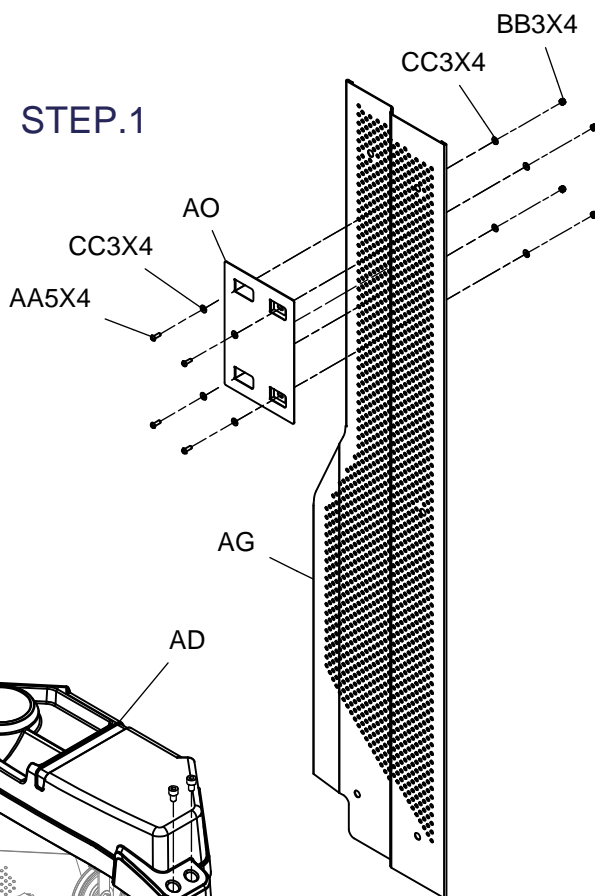

M10X15L ROUND INNER HEAD X4

M6 WASHER Ø16 X10

ROUND BOLT M6X16L X10

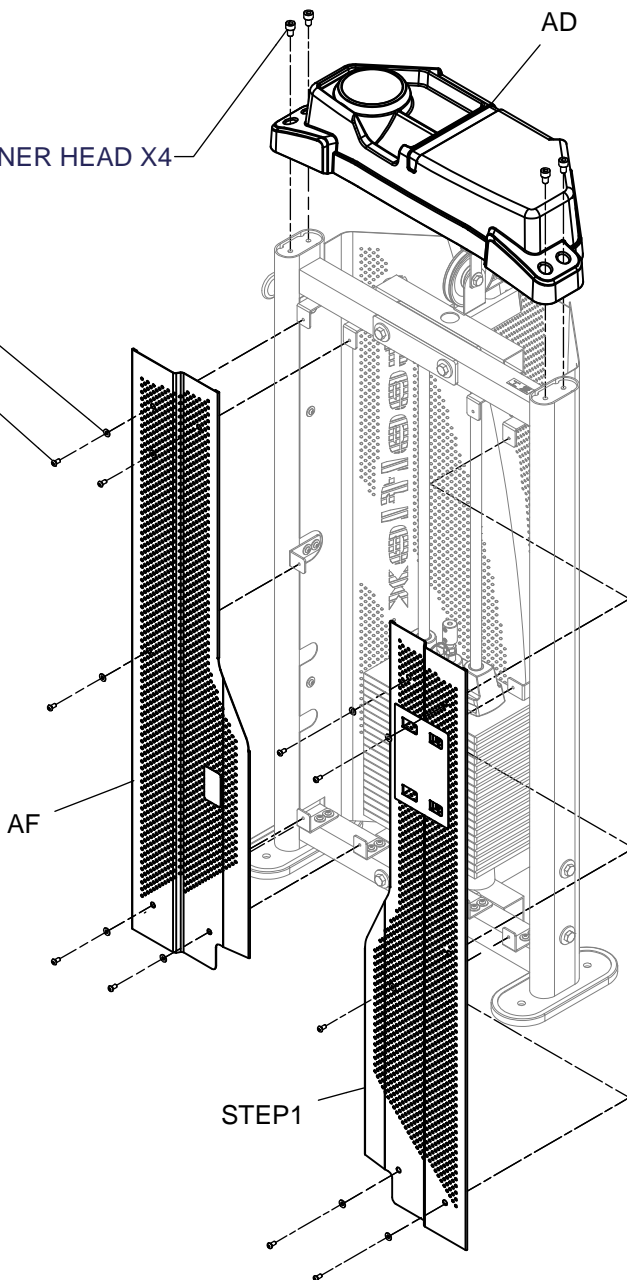

# HLE200 ASSEMBLY INSTRUCTIONS

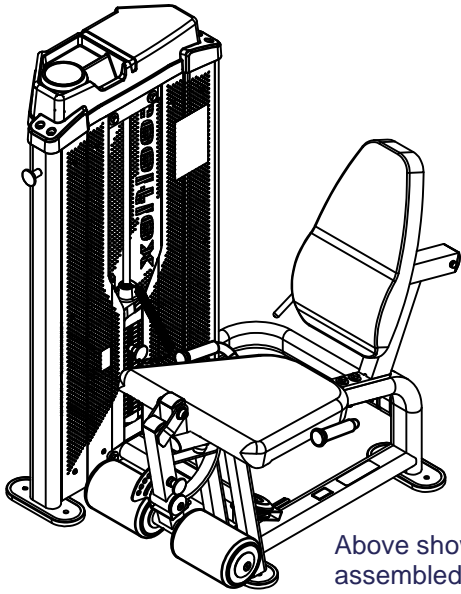

Above shows STEP 8 assembled and completed

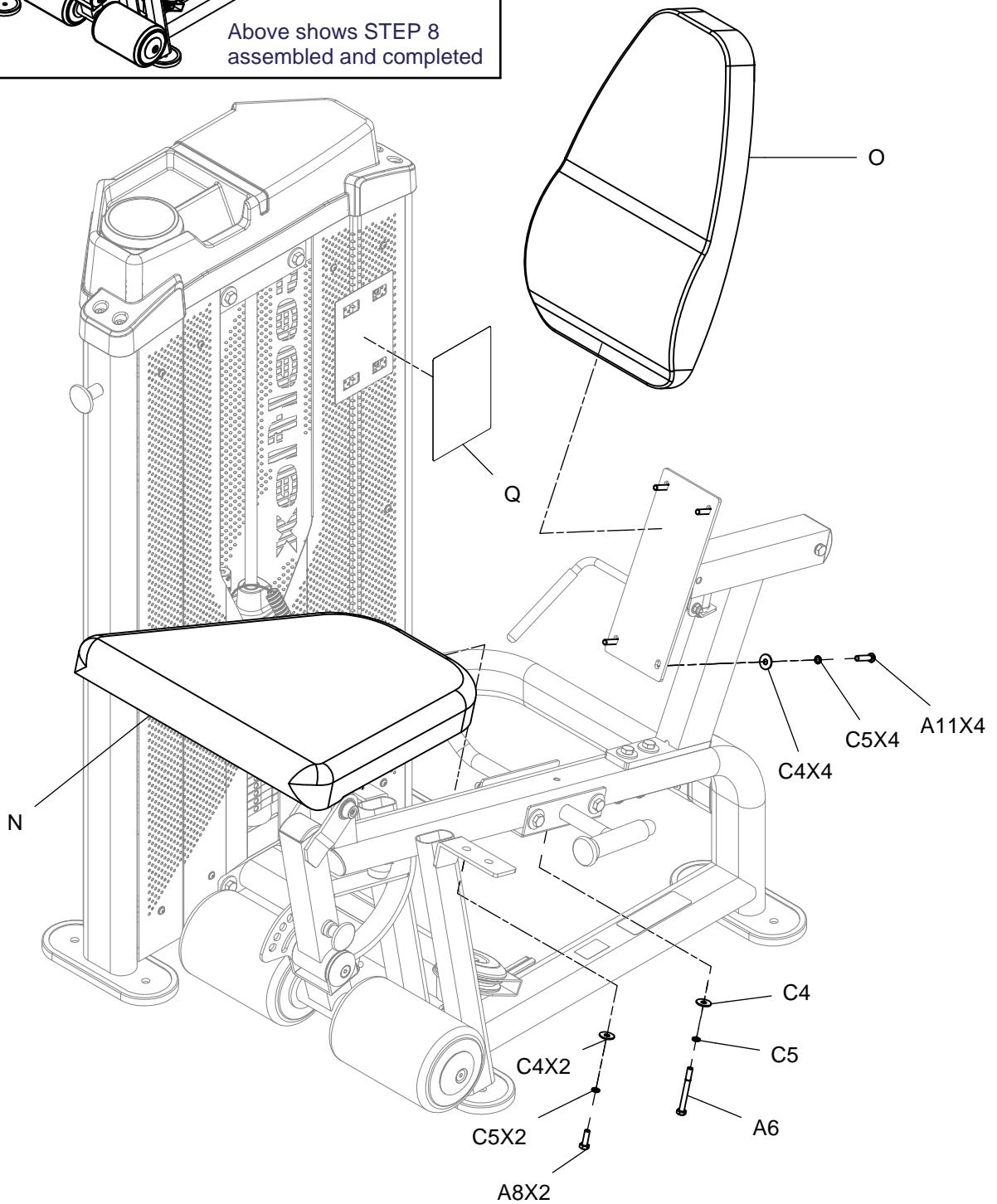

# HOPE ASSEMBLY INSTRUCTIONS

## DECAL REFERENCE

<b>MAINTENANCE SCHEDULE</b>		D	A	I	L	L	Y
Check the function and integrity of the following components. As noted, inspect equipment before each workout. Replace all damaged, broken or worn components immediately.							
Cables:	Check tension, end fittings, and coating	✓					
	Check that locking nut at weight stack is tight		✓				
Upholstery:	Wipe down and dry	✓					
	Clean and condition		✓				
Frame:	Wipe down and dry	✓					
	Polish / Wax		✓				
Chrome:	Wipe down and dry	✓					
	Polish / Lubricate		✓				
Nut / Bolts / Fasteners:	Tighten and / or adjust as needed	✓					
Guide Rods:	Lubricate and clean	✓					
Linear Rods:	Lubricate and clean	✓					
Seat Sleeves:	Lubricate and clean	✓					
Adjustments / Locking Pins / Tightening Knobs		✓					
Weight Stack Pins		✓					
Warning Instruction Labels		✓					
Springs / Pop Pins		✓					
Anti Skid Surfaces		✓					
Hand Grips / Rollers		✓					

For Steelflex Customer Service  
Call +886 2 27209980

9440-258

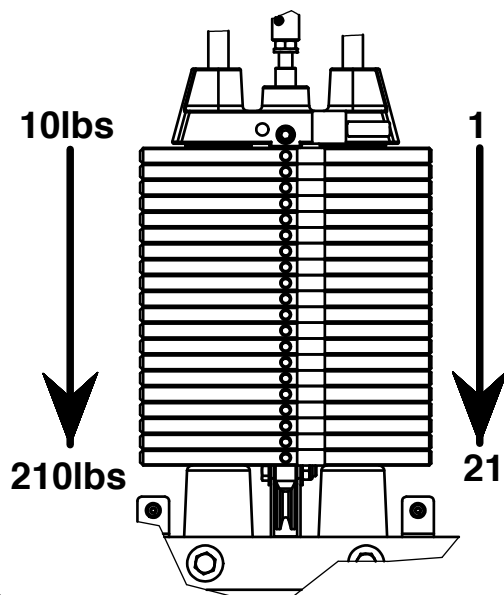

HOPE-042014

**THERE IS A RISK ASSUMED BY INDIVIDUALS WHO USE THIS TYPE OF EQUIPMENT. TO MINIMIZE RISK, YOU MUST FOLLOW THESE RULES:**

1. Inspect equipment before each workout. Check that all nuts, bolts, screws and pop pins are in place and fully tightened. Also, before use, check cables for signs of wear. Replace all worn parts immediately. Never use machine if any parts are damaged or missing.
2. Keep clear of the cables and all moving parts when the machine is in use.
3. Always make sure all Snap Links are closed when doing any cable/pulley/strap exercises.
4. Exercise with care. Perform your exercises at a smooth moderate pace; never perform jerky or uncoordinated movements that may cause injury.
5. It is recommended that you should workout with a training partner.
6. Do not allow children or minors to play on or around this equipment.
7. If unsure of proper use of equipment, call Steelflex Customer Service +886 2 27209980.
8. **WARNING:** Consult your physician before starting your exercise program. For your own safety, do not begin any exercise program without proper instruction.

9440-259



9440-047

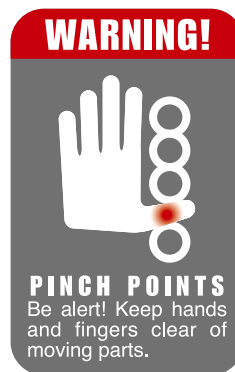

9440-117