

HOPPE

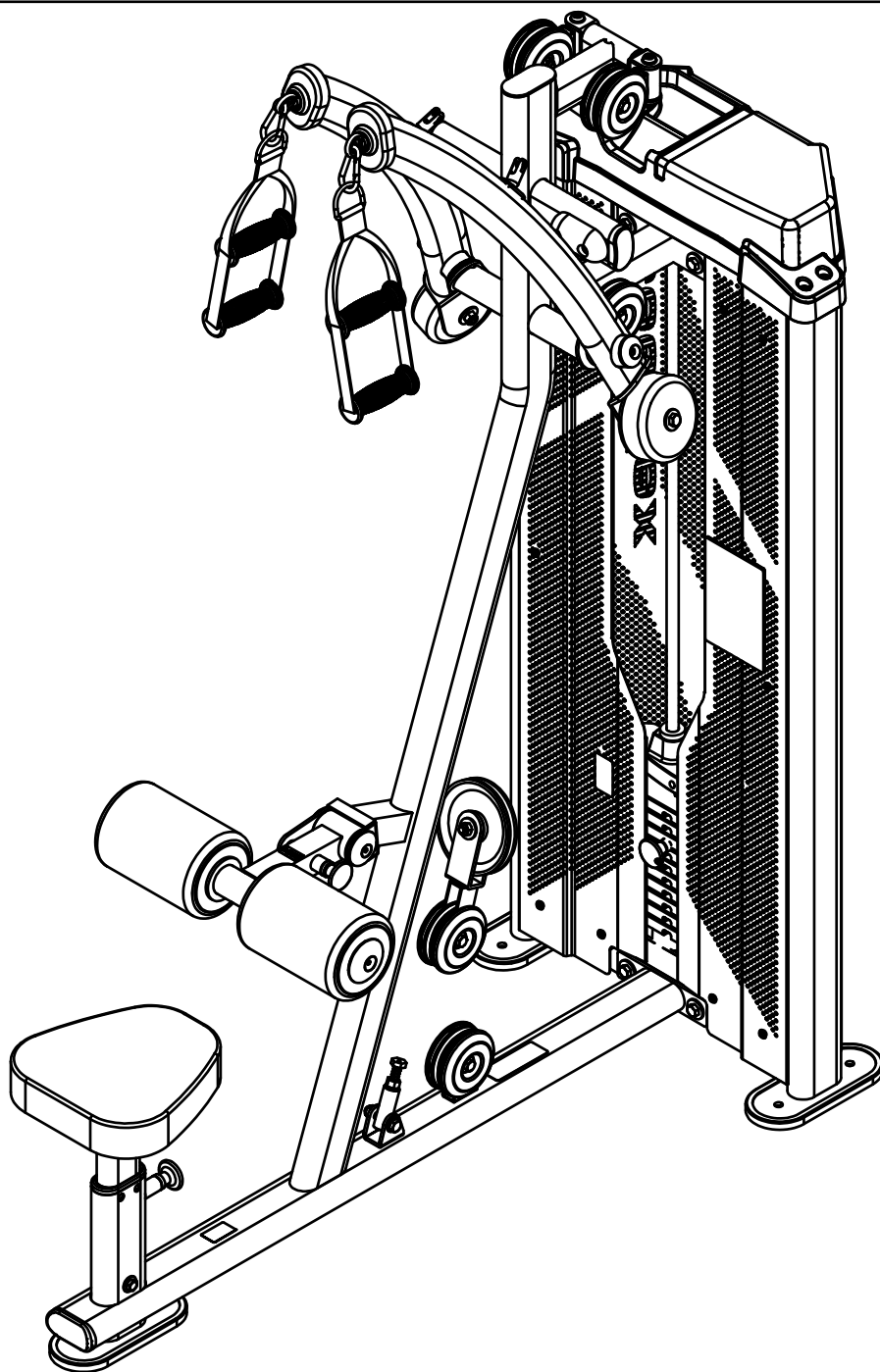

JOONG CHENN INDUSTRY CO., LTD.

Sales Office:

3F28, No.5, Shin-Yi Rd., Sec. 5, Taipei, Taiwan 110 R.O.C.

Tel: 886-2-27209980

Fax: 886-2-27229750

www.steelflexfitness.com

HLM-300.3 OWNER'S MANUAL

HLM-300 ASSEMBLY INSTRUCTIONS

HARDWARE ILLUSTRATION

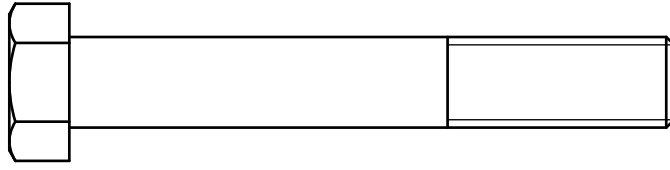
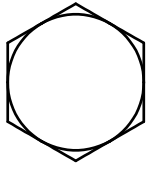

(A1)HEX BOLT M12X80L PARTIAL THREAD QTY.2

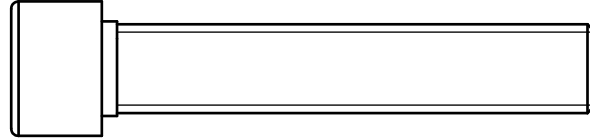
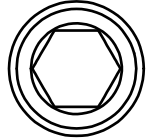

(A2)ROUND ALLEN HEAD M12X65L PARTIAL THREAD QTY.4

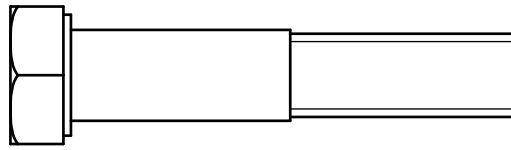
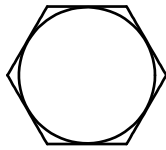

(A3)HEX BOLT M12X60L PARTIAL THREAD QTY.2

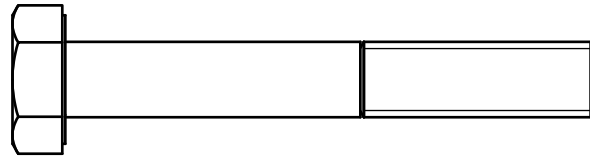
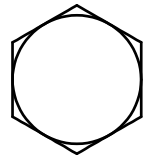

(A4)HEX BOLT M10X70L PARTIAL THREAD QTY.2

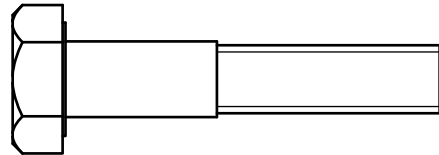
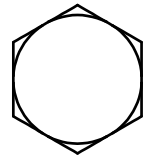

(A5)HEX BOLT M10X50L PARTIAL THREAD QTY.6

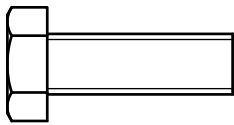
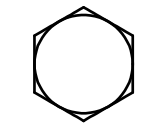

(A7)HEX BOLT M8X25L PARTIAL THREAD QTY.4

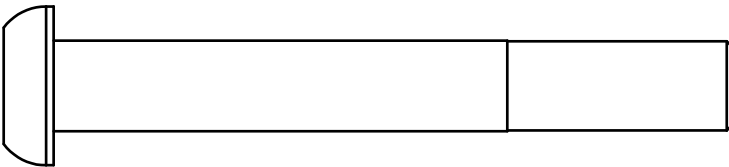
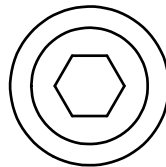

(A8)ROUND ALLEN HEAD M12X90L PARTIAL THREAD QTY.2

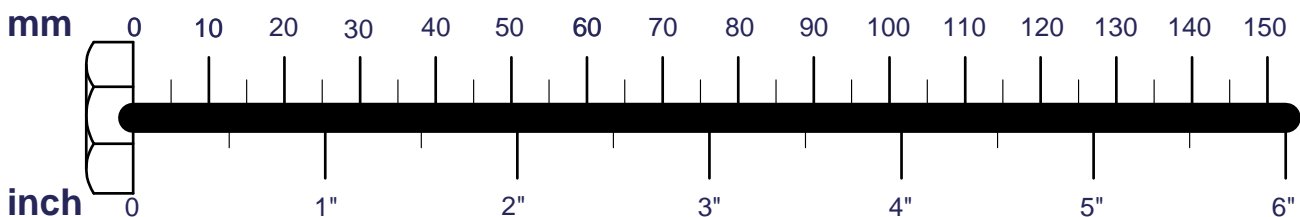

HLM-300 ASSEMBLY INSTRUCTIONS

FRAME HARDWARE ILLUSTRATION FOR DOOR

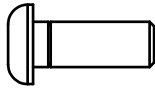

(AA1)ROUND ALLEN HEAD M6X16L PARTIAL THREAD QTY.24

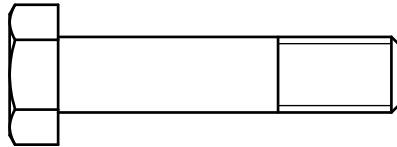
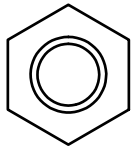

(AA2)HEX BOLT M10X45L PARTIAL THREAD QTY.2

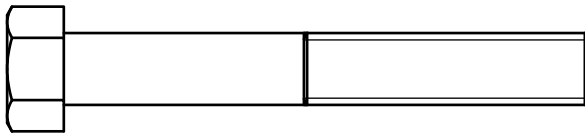
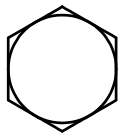

(AA4)HEX BOLT 3/8"X2-3/4"L PARTIAL THREAD QTY.1

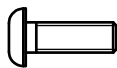

(AA5)ROUND ALLEN HEAD M4X12L PARTIAL THREAD QTY.4

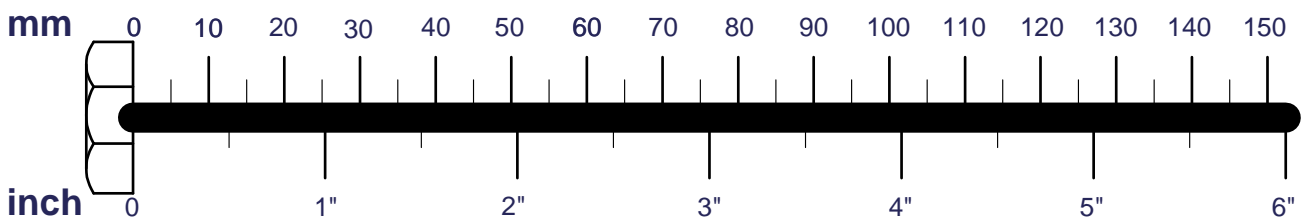

HLM-300 ASSEMBLY INSTRUCTIONS

FRAME HARDWARE ILLUSTRATION FOR DOOR

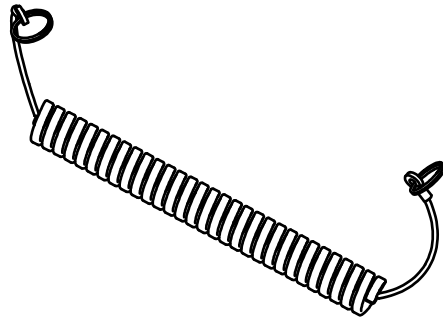

(AA6)ELASTIC BELT (F920003) QTY.1

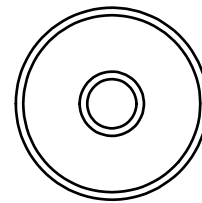
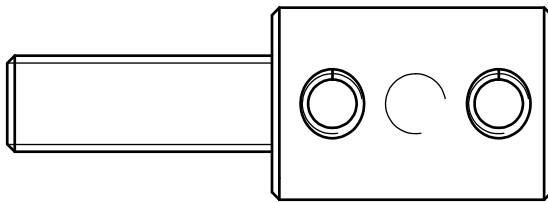

(AA8)WEIGHT STACK CABLE (8260-009) QTY.1

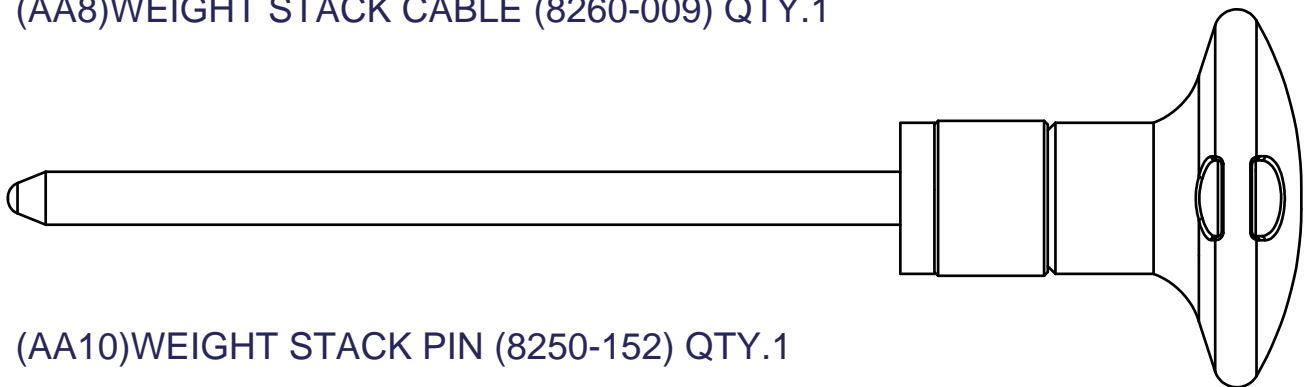

(AA10)WEIGHT STACK PIN (8250-152) QTY.1

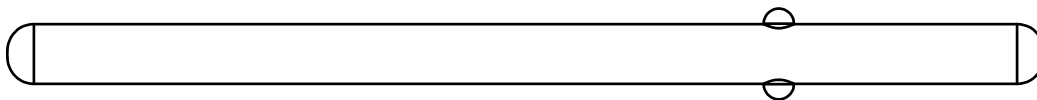

(AA11)Ø5/16" FIXED PIN (8250-166) QTY.1

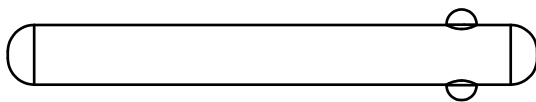

(AA12)Ø5/16" FIXED PIN (8250-167) QTY.1

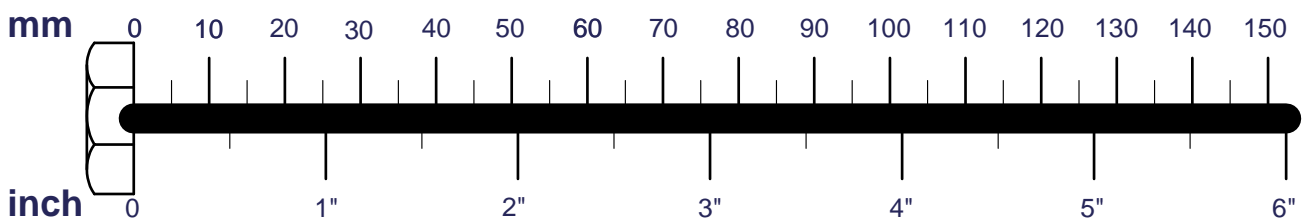

HLM-300 ASSEMBLY INSTRUCTIONS

HARDWARE ILLUSTRATION

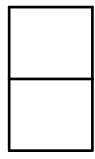
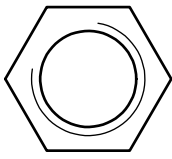

(B1) LOCK NUT 1/2" X13UNC QTY.1

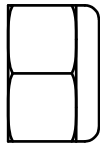
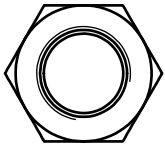

(B2) NYLON LOCK NUT M12 QTY.10

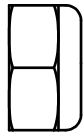
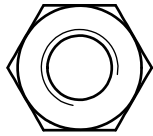

(B3) NYLON LOCK NUT M10 QTY.4

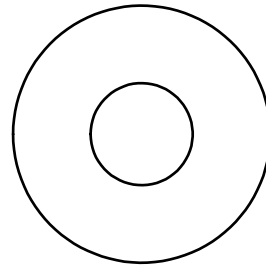

(C2) M12(I.D.) FLAT WASHER Ø34 QTY.10

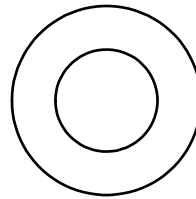

(C3) M12(I.D.) FLAT WASHER Ø25 QTY.2

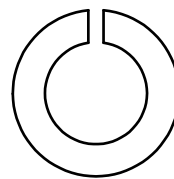

(C4) 1/2" SPRING WASHER QTY.1

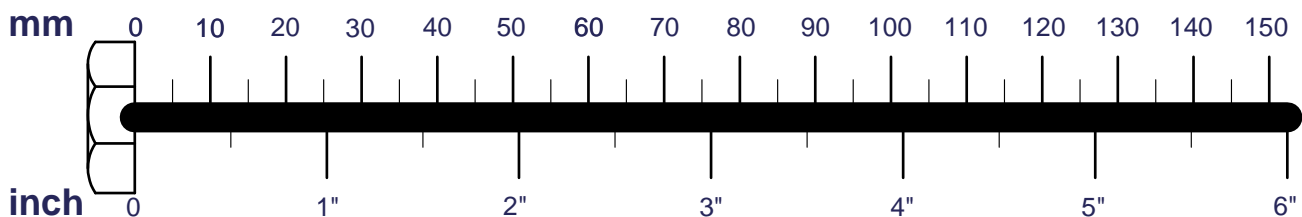

HLM-300 ASSEMBLY INSTRUCTIONS

FRAME HARDWARE ILLUSTRATION FOR DOOR

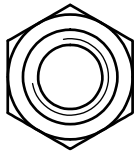

(BB1) NYLON LOCK NUT M10 QTY.2

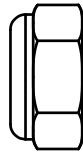

(CC4) M6(I.D.) FLAT WASHER Ø19 QTY.24

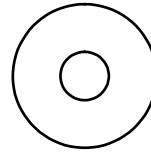

(BB2) LOCK NUT 1/2"X13 UNC QTY.1

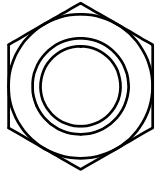

(BB3) NYLON LOCK NUT M4 QTY.4



(CC6) 1/2" SPRING WASHER QTY.1



(CC1) M10(I.D.) FLAT WASHER Ø27 QTY.5



(CC7) M4(I.D.) FLAT WASHER Ø10 QTY.8

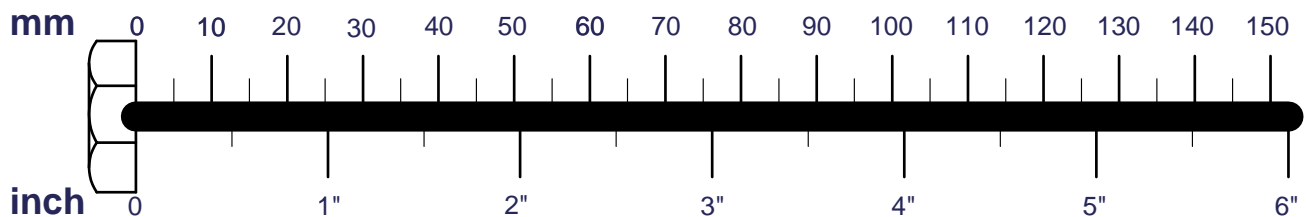
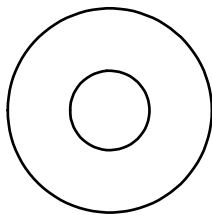
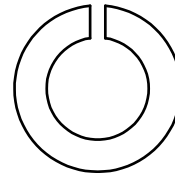

HLM-300 ASSEMBLY INSTRUCTIONS

HARDWARE ILLUSTRATION

D2. ϕ 50 End Cap (8130-131)	-----	[2PCS]
D3. ϕ 60 End Cap (8130-231)	-----	[2PCS]
D4. ϕ 76 End Cap (8130-236)	-----	[2PCS]
D5. ϕ 1" Sleeve (8220-244)	-----	[1PCS]
D6. ϕ 8 Hook (8810-001)	-----	[2PCS]
D7. ϕ 38 Nylon Washer (9214-039)	-----	[4PCS]
D8. 40x80 End Plug (9211-113)	-----	[2PCS]
D9. 50x100 End Plug (9211-114)	-----	[1PCS]

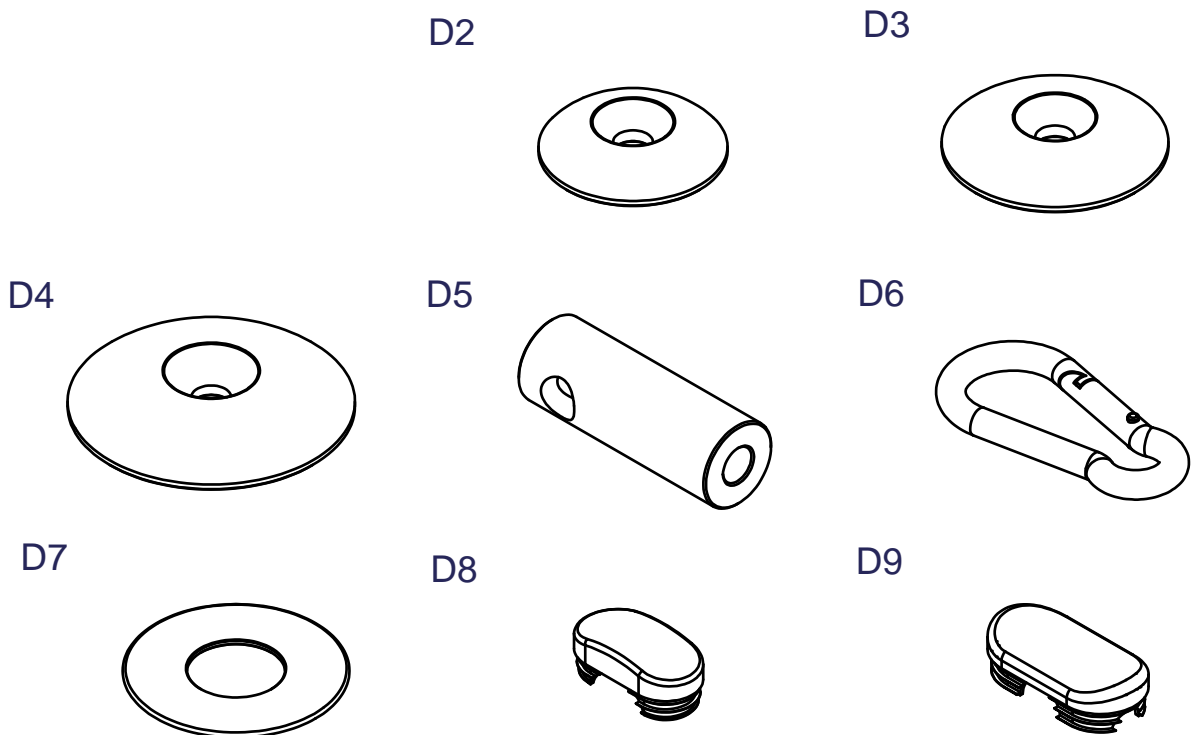

HLM-300 ASSEMBLY INSTRUCTIONS

D10. Plully Cap (9211-173)	-----	[10PCS]
D11. Rubber Pad (9310-057)	-----	[2PCS]
D12. Rubber Pad (9310-075)	-----	[1PCS]
D13. Handgrips (9630-243)	-----	[2PCS]
D14. ø110 Pully (9213-002B)	-----	[6PCS]
D16. Exercise Chart (9420-079)	-----	[1PCS]
D17. ø12.7X26.5L Pin (8690-004)	-----	[2PCS]
D18. ø8x0.8t E Ring (8781-070)	-----	[2PCS]
D19. 3570 mm Steel Cable (FHLM300A)	-----	[1PCS]
D20. 4110 mm Steel Cable (FHLM300B2)	-----	[1PCS]
D21. 3/8" Coper Washer (8520-008)	-----	[2PCS]
D22. Ø6" PULLY(9213-009C)	-----	[1PCS]

D10

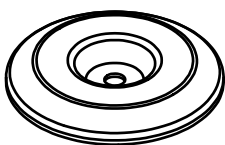

D11

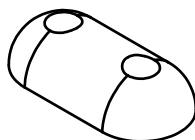

D12

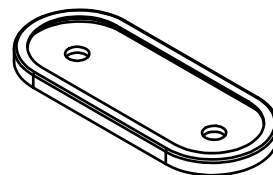

D13

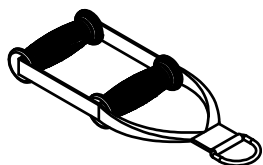

D14

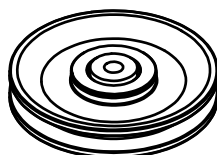

D16

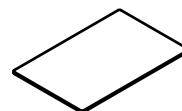

D17



D18



D21



D19

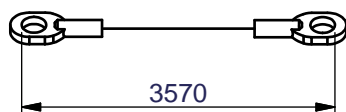

D20

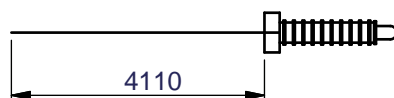

D22

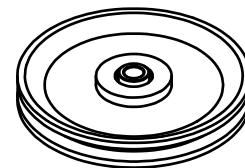

HLM-300 ASSEMBLY INSTRUCTIONS

FRAME HARDWARE ILLUSTRATION FOR DOOR

- DD1. 3/4" Shaft Collar (9211-046) -----[2PCS]
- DD2. 2"x2" Rubber Cane Cap (9214-002) -----[3PCS]
- DD3. Tower Rack (9215-024)-----[1PCS]
- DD4. $\phi 65 \times \phi 20 \times 70L$ Rubber Dount (9310-049) -----[2PCS]
- DD5. $\phi 40 \times 10 \times \phi 20$ Rubber Pad (9310-097) -----[2PCS]
- DD6. 108x14.5tx263 Rubber Pad (9310-075)-----[2PCS]
- DD7. $\phi 110$ Pully (9213-002B) -----[2PCS]
- DD8. Top Plate (8400-006) -----[1PCS]
- DD10. Selector Rod (8210-191) -----[1PCS]

DD1



DD2

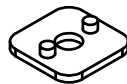

DD3



DD4

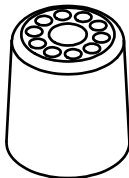

DD6

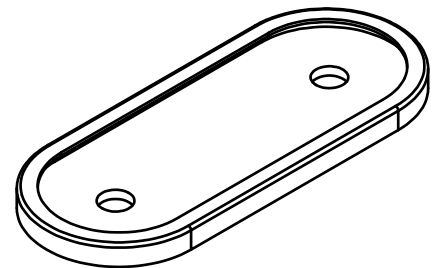

DD7

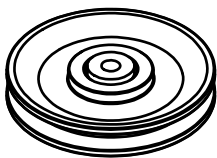

DD8

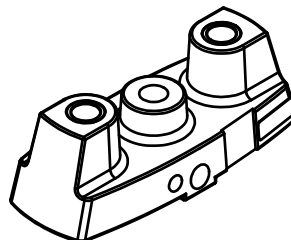

DD10

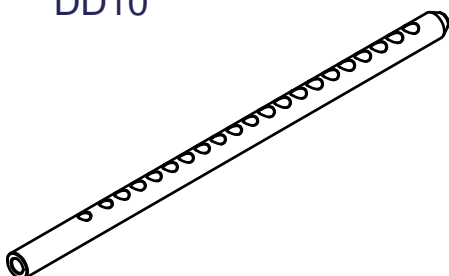

HLM-300 ASSEMBLY INSTRUCTIONS

PARTS ILLUSTRATION SHEET

A1[1PCS]

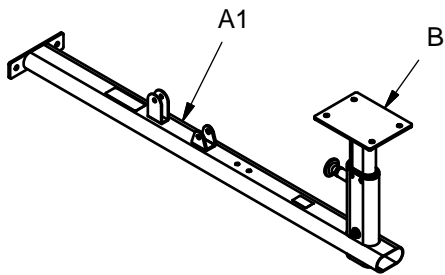

C2[1PCS]

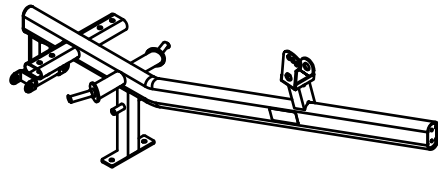

D[1PCS]

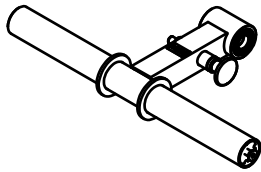

E[1PCS]

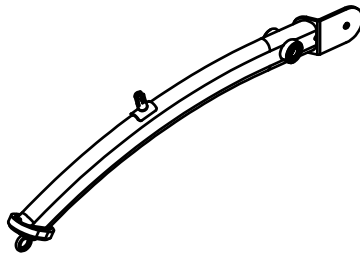

F[1PCS]

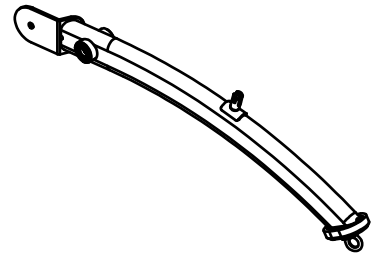

G1[1PCS]

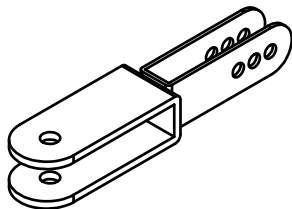

H1[2PCS]

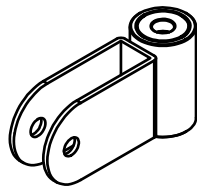

I[2PCS]
8230-023

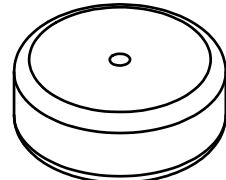

J[1PCS]
8313-188

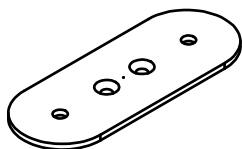

K[1PCS]
9121-093

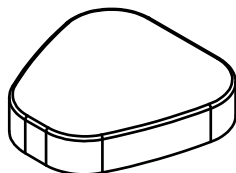

L1[2PCS]
9161-078

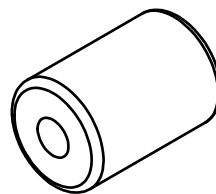

M[1PCS]
8220-186

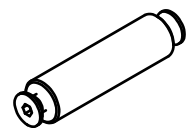

HLM-300 ASSEMBLY INSTRUCTIONS

FRAME PARTS ILLUSTRATION SHEET FOR DOOR

AA[1PCS]
6610-026

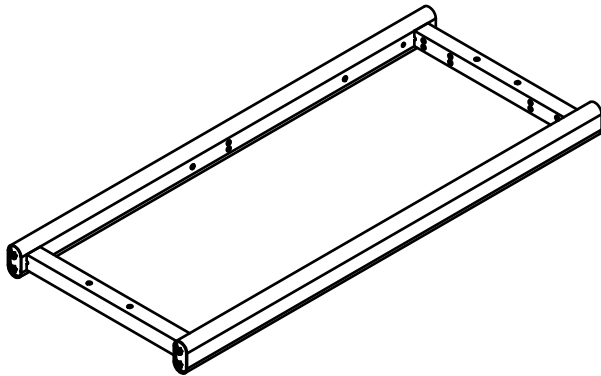

AB[1PCS]
9211170-023

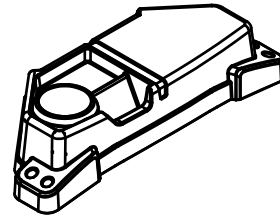

AC[1PCS]
8380-069

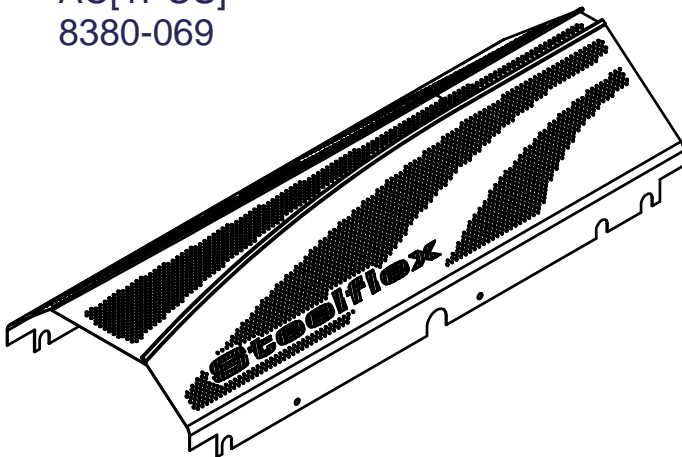

AD[1PCS]
8380-070

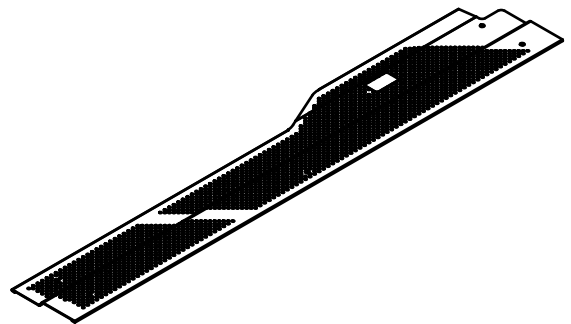

AE[1PCS]
8380-071

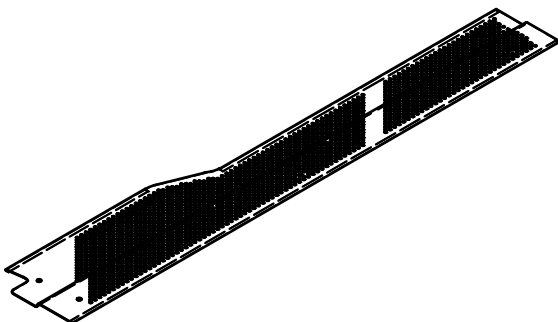

AF[1PCS]
6610-017

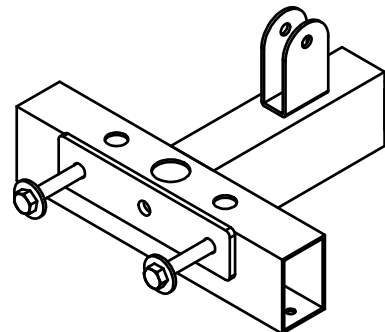

HLM-300 ASSEMBLY INSTRUCTIONS

FRAME PARTS ILLUSTRATION SHEET FOR DOOR

AG[1PCS]
6610-018

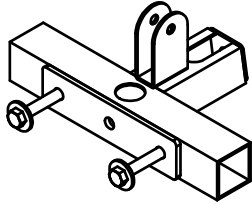

AH[4PCS]
8331-065

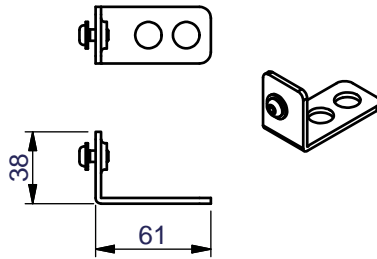

AI[6PCS]
8331-064

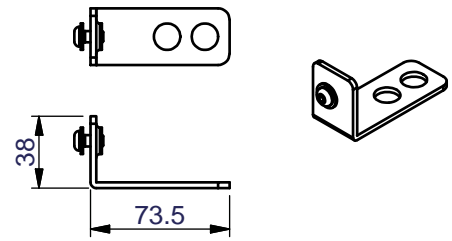

AJ[2PCS]
8313-188

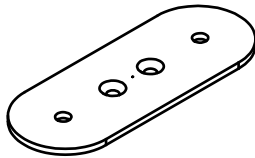

AK[1PCS]
8331-017

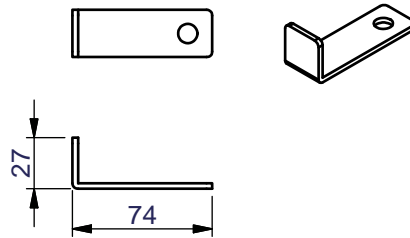

AL1[2PCS]
8280-037
Ø3/4"X1522L

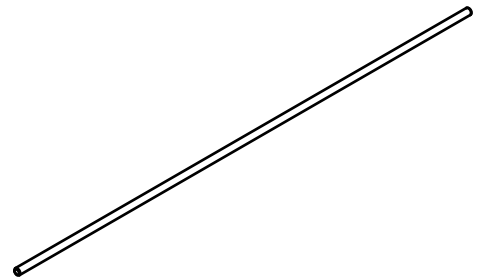

AN[1PCS]
8345-014

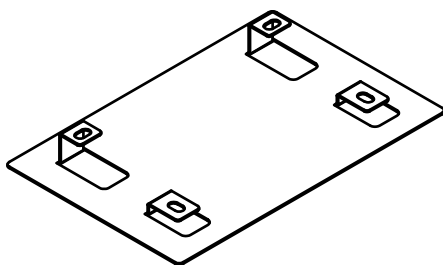

AO[1PCS]
8311-194

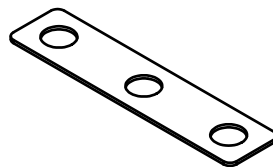

HLM-300 ASSEMBLY INSTRUCTIONS

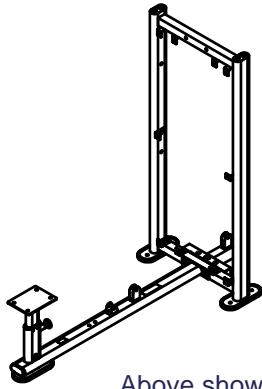

Above shows STEP 2
assembled and completed

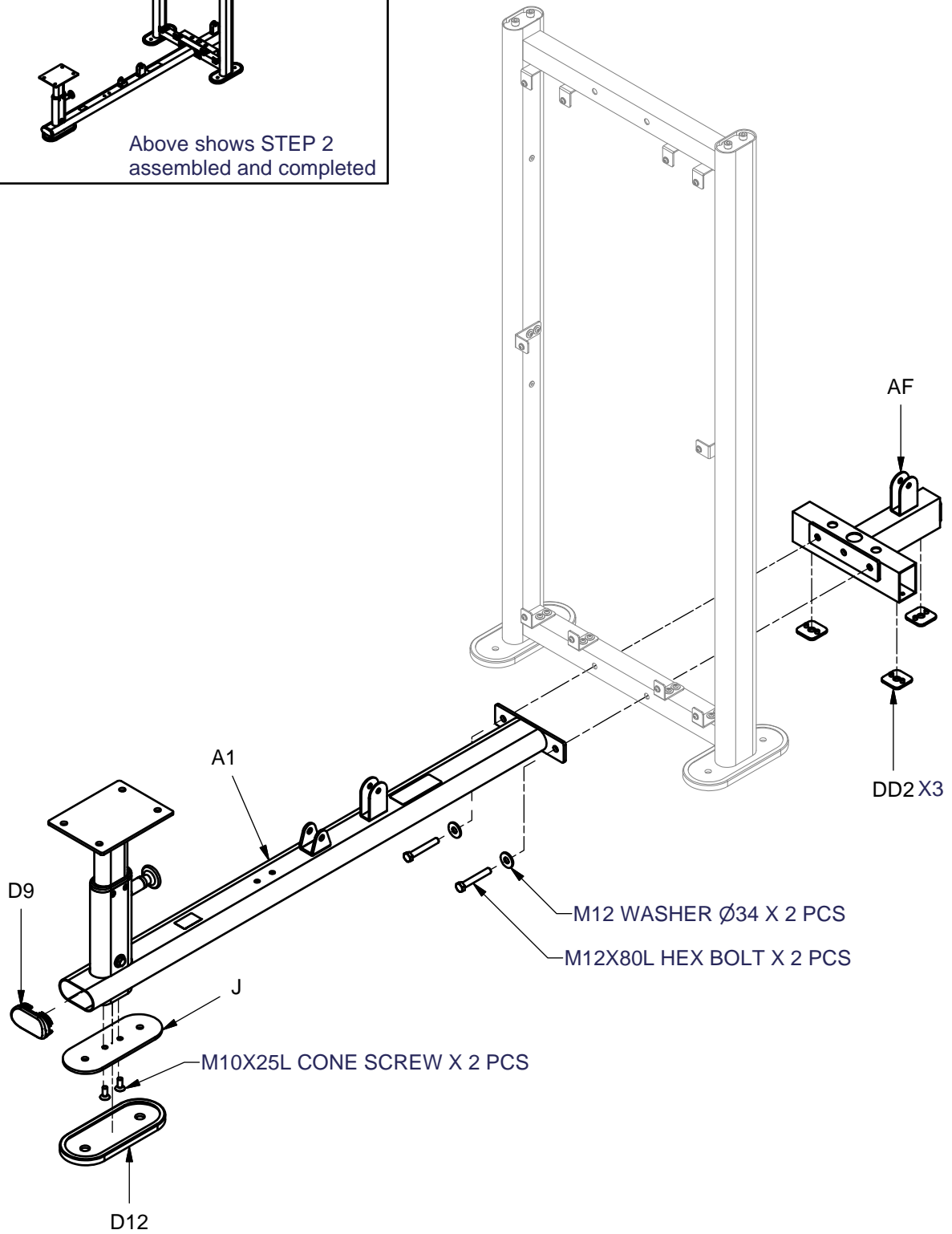

HLM-300 ASSEMBLY INSTRUCTIONS

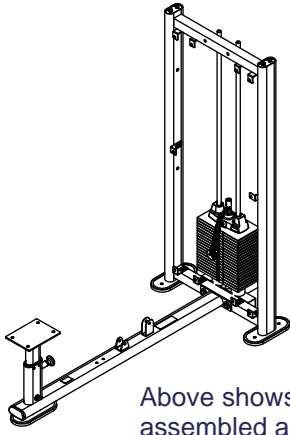

Above shows STEP 3 assembled and completed

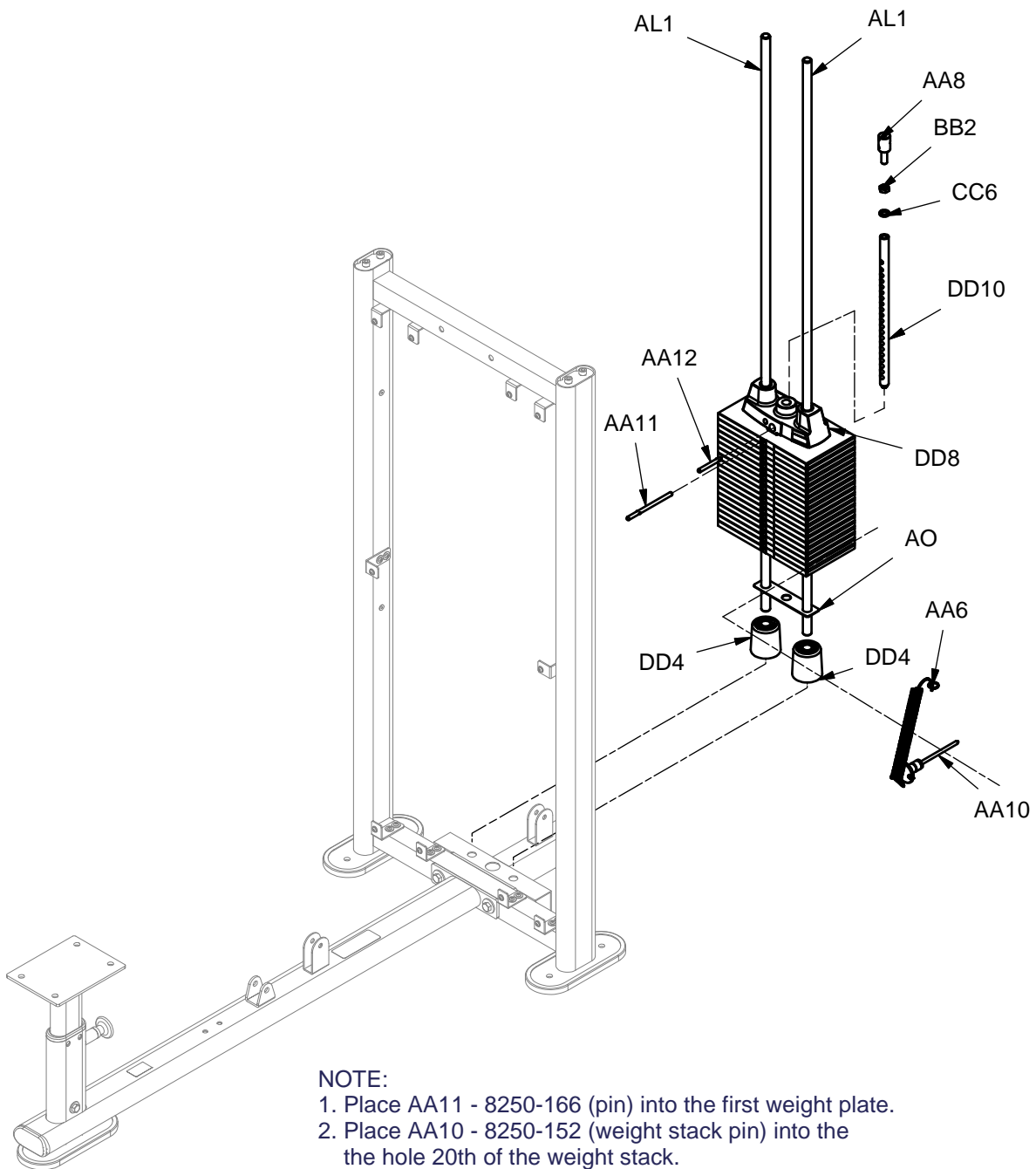

NOTE:

1. Place AA11 - 8250-166 (pin) into the first weight plate.
2. Place AA10 - 8250-152 (weight stack pin) into the the hole 20th of the weight stack.
3. Make sure DD8- 8400-006A(top plate) cling to (first weight plate) and fix in AA12 - 8250-167(pin).
4. Finally remove AA10 - 8250-152 (weight stack pin) and use as usual.

HLM-300 ASSEMBLY INSTRUCTIONS

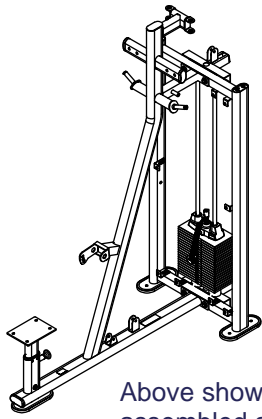

Above shows STEP 4 assembled and completed

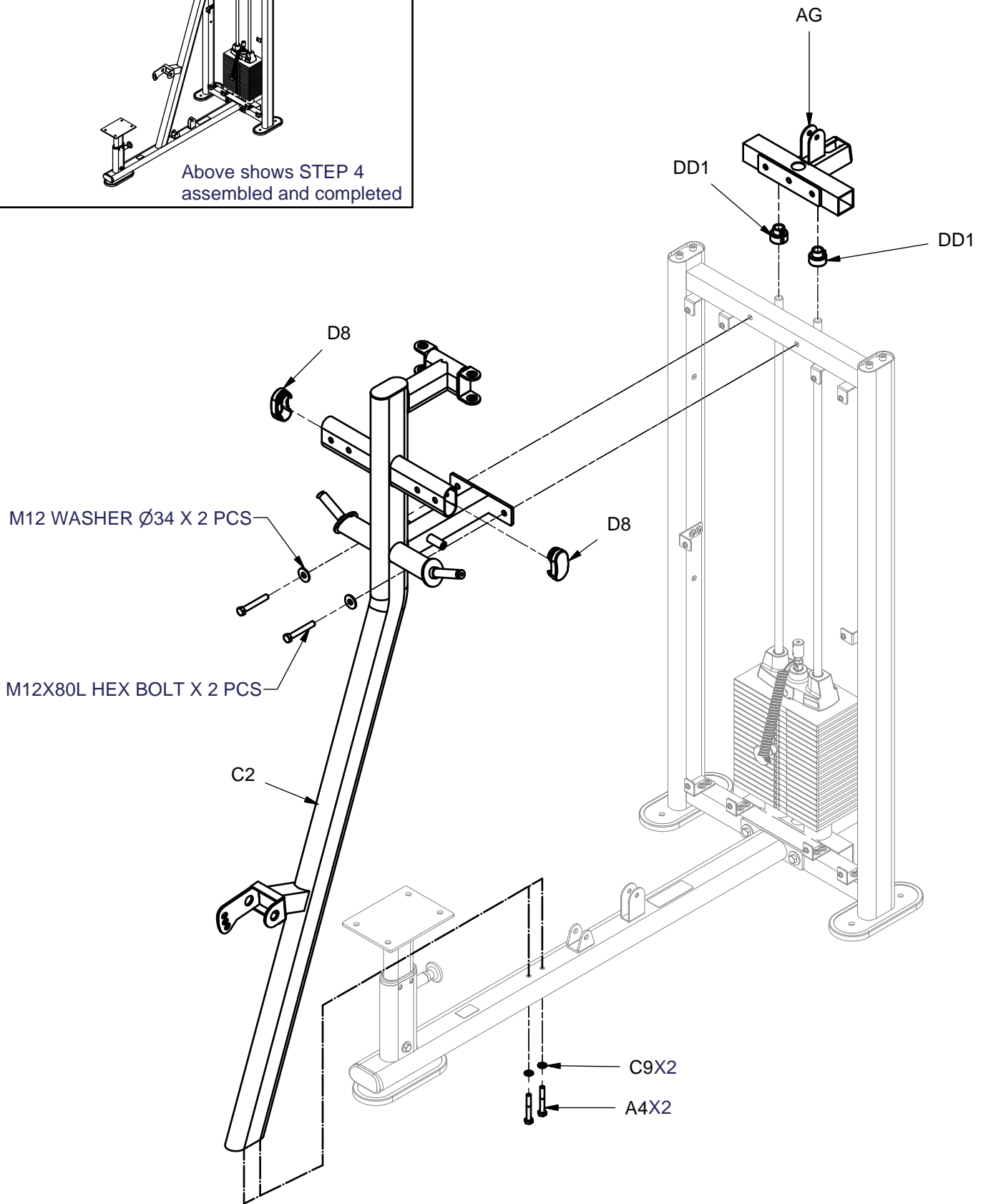

HLM-300 ASSEMBLY INSTRUCTIONS

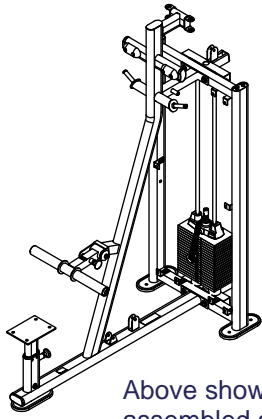

Above shows STEP 5
assembled and completed

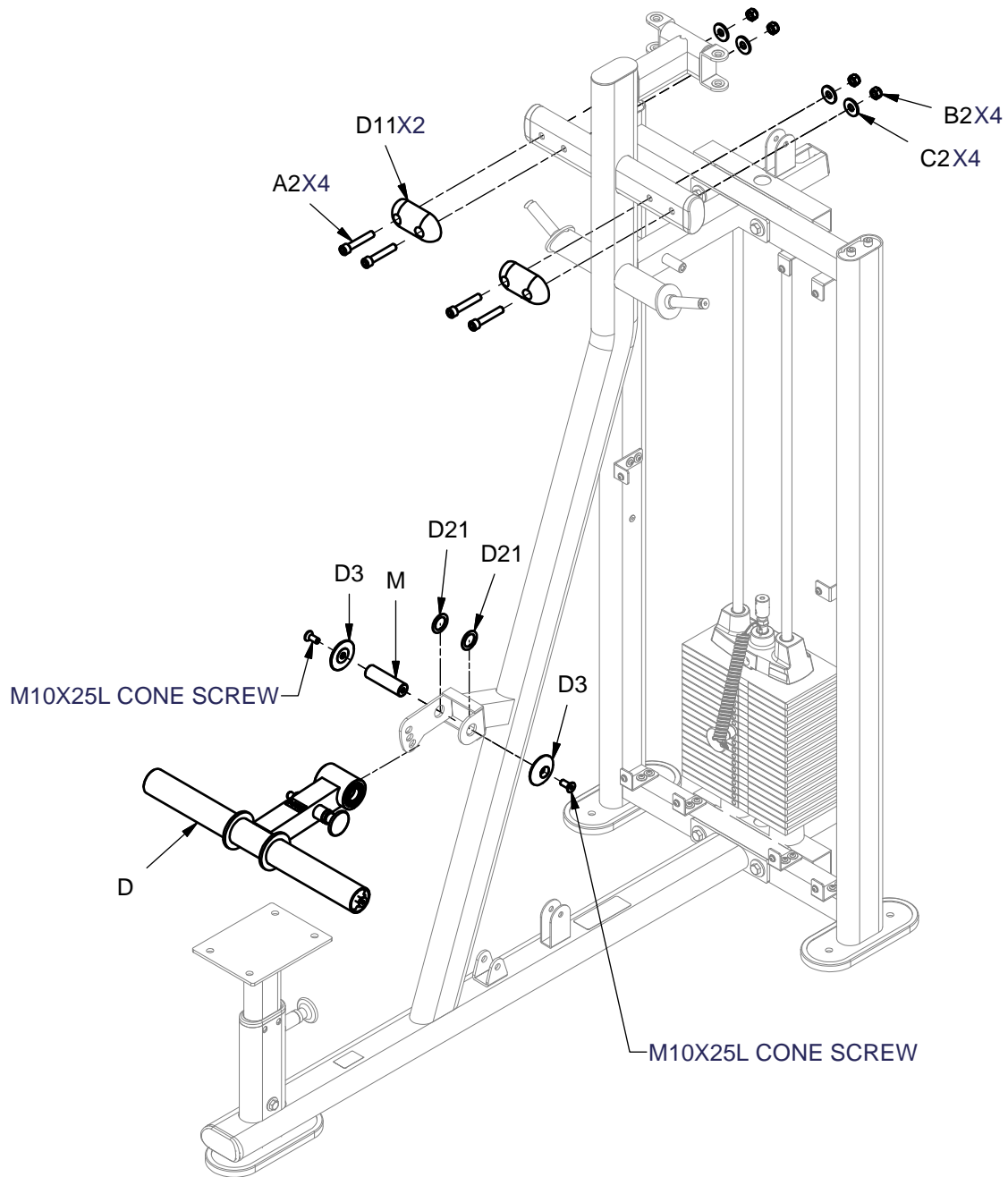

HLM-300 ASSEMBLY INSTRUCTIONS

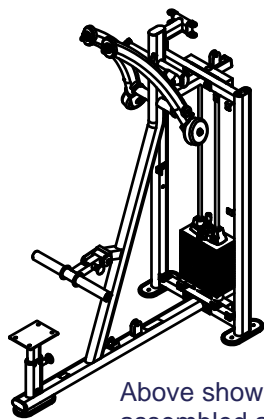

Above shows STEP 6
assembled and completed

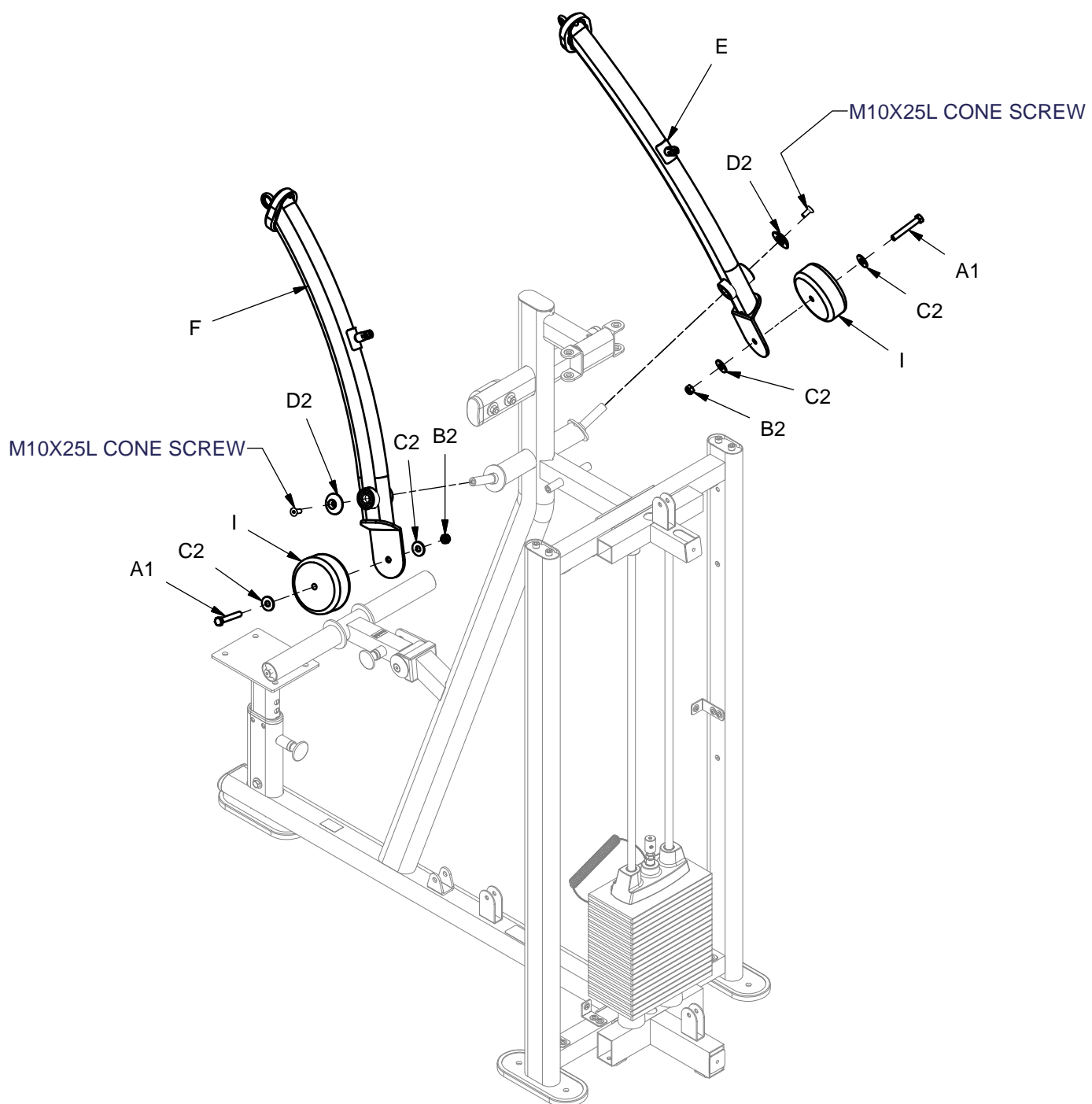

HLM-300 ASSEMBLY INSTRUCTIONS

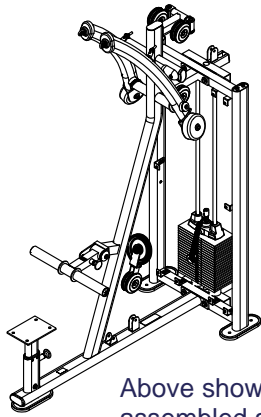

Above shows STEP 7 assembled and completed

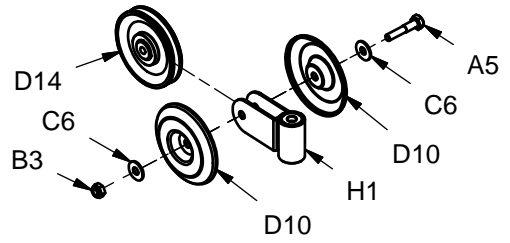

Figure 1

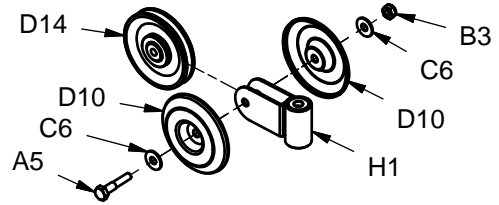
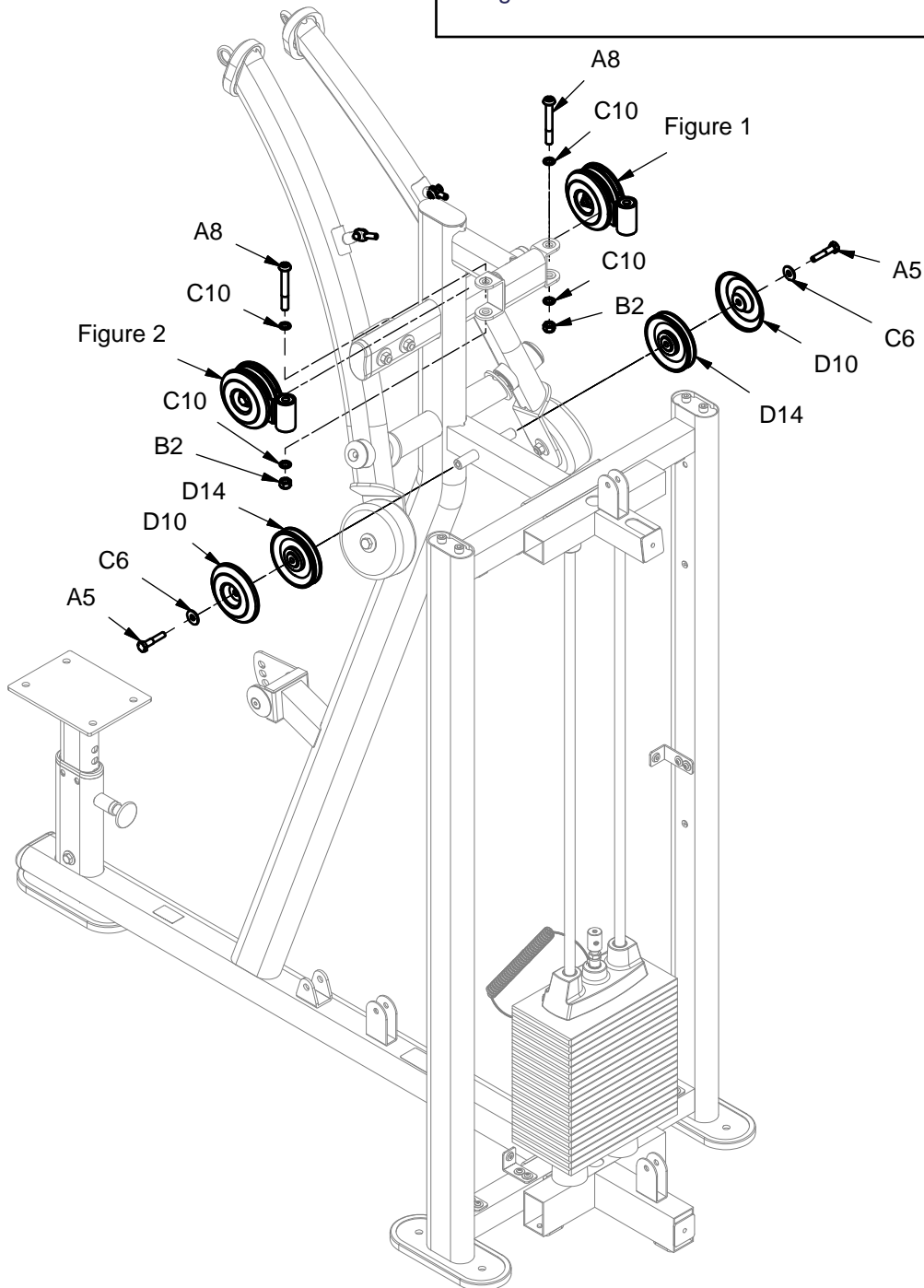

Figure 2



HLM-300 ASSEMBLY INSTRUCTIONS

Cable To Constitute Illustration

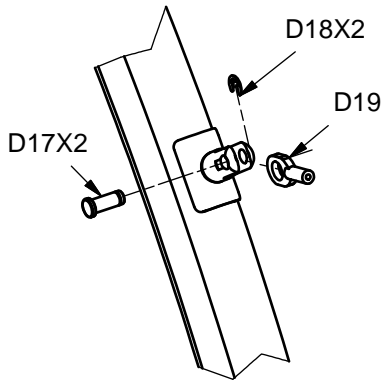

Figure 3

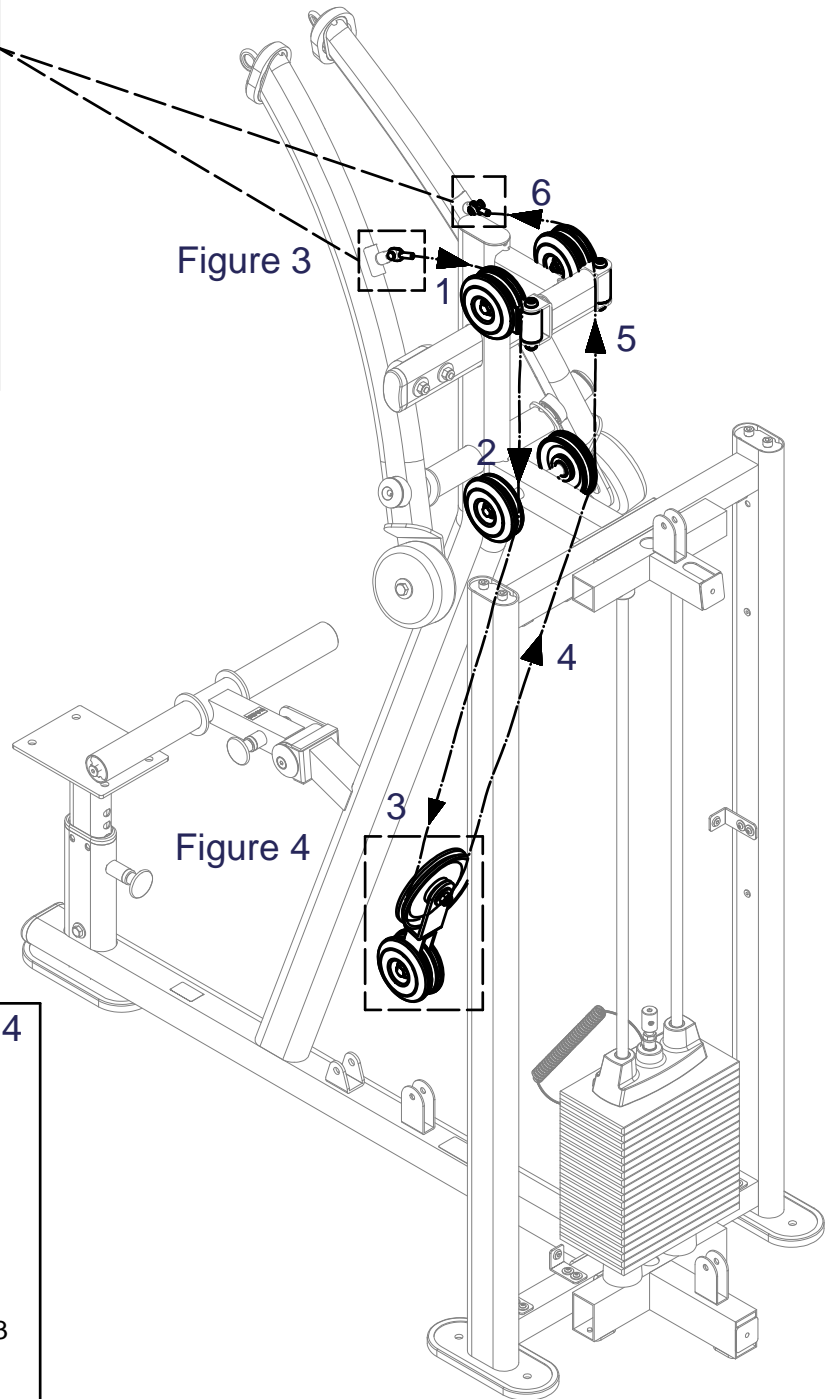

Figure 4

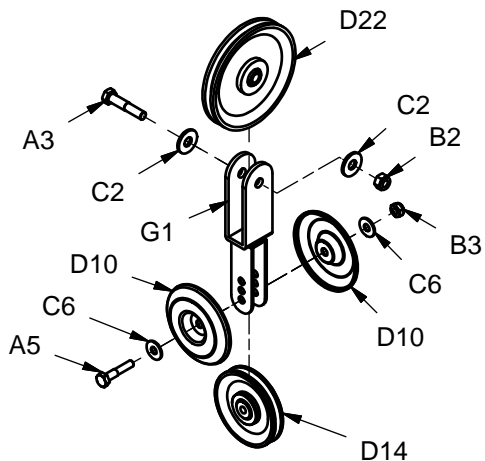
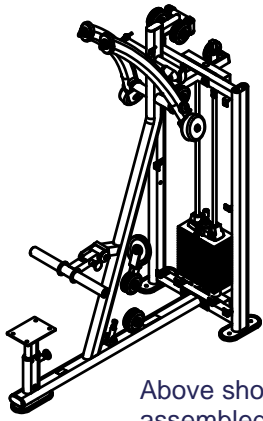
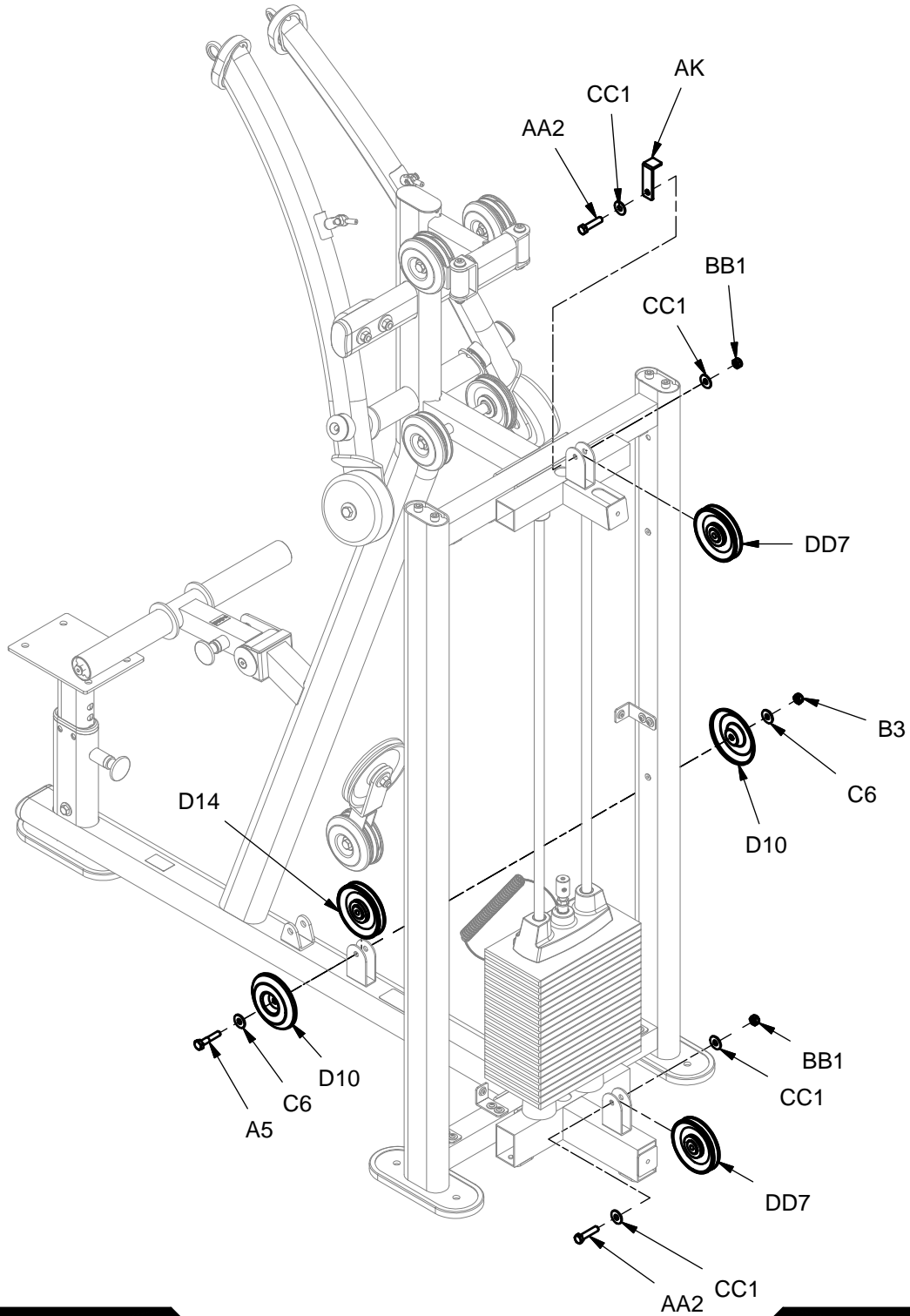

Figure 4

HLM-300 ASSEMBLY INSTRUCTIONS



Above shows STEP 8 assembled and completed



HLM-300 ASSEMBLY INSTRUCTIONS

Cable To Constitute Illustration

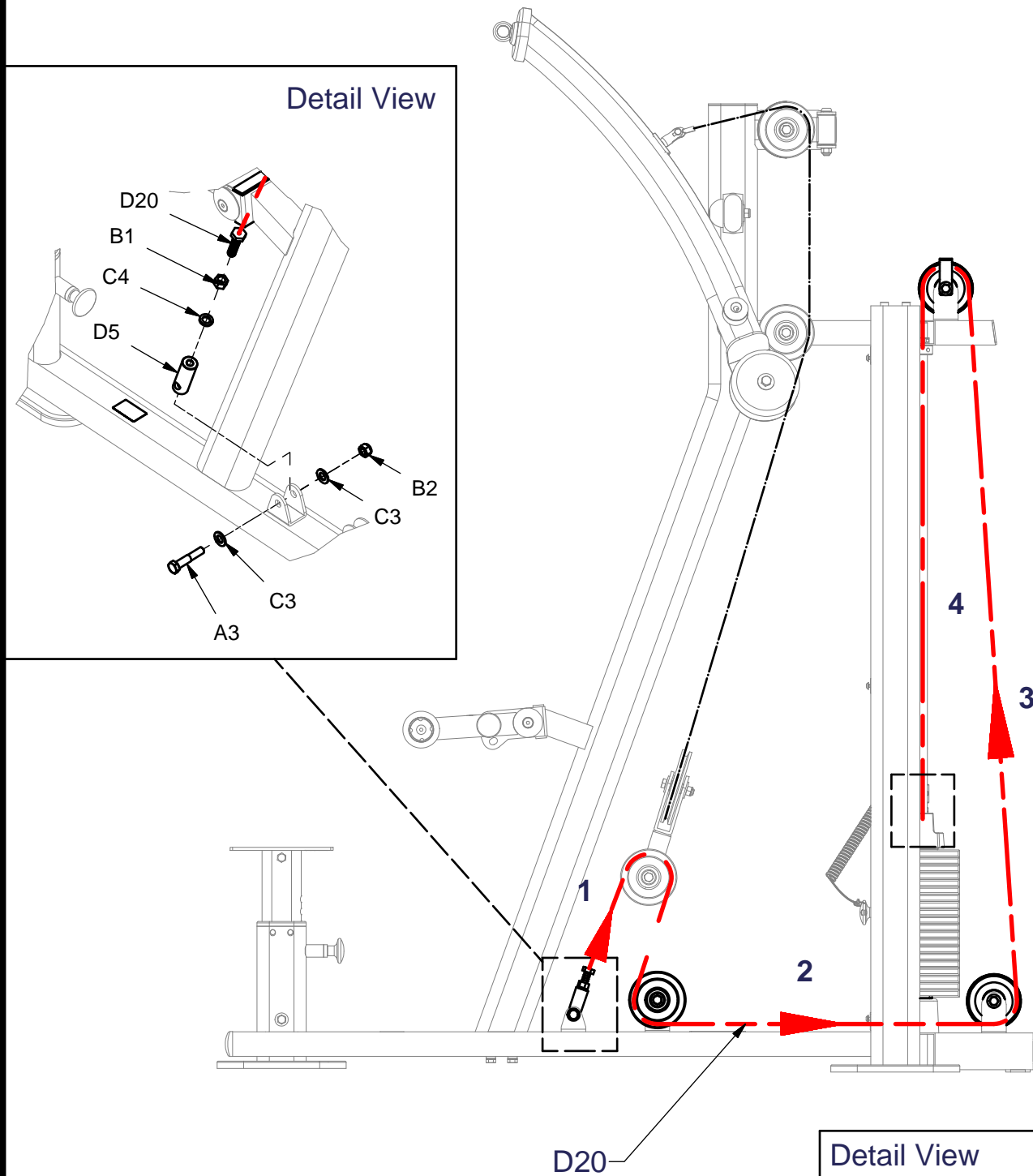

Detail View

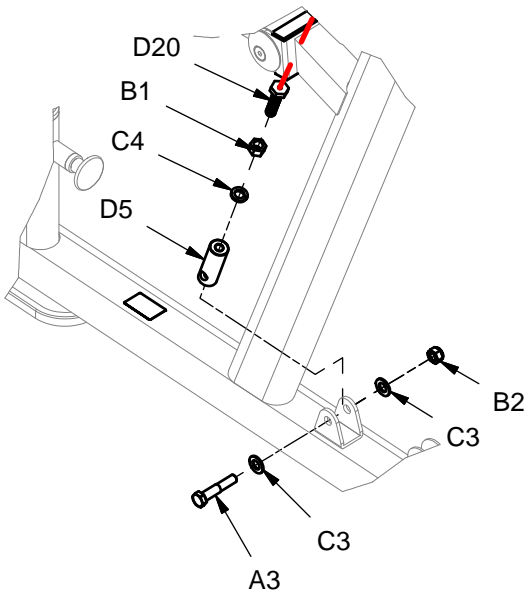

Detail View

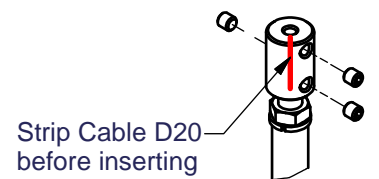

HLM-300 ASSEMBLY INSTRUCTIONS

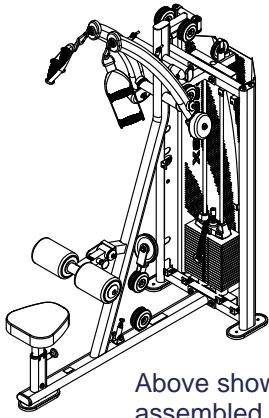

Above shows STEP 9 assembled and completed

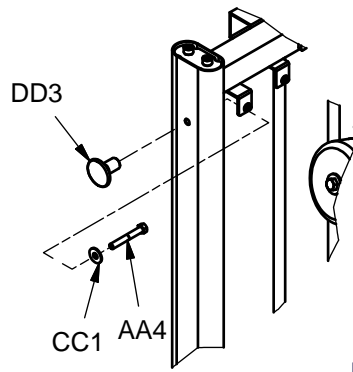
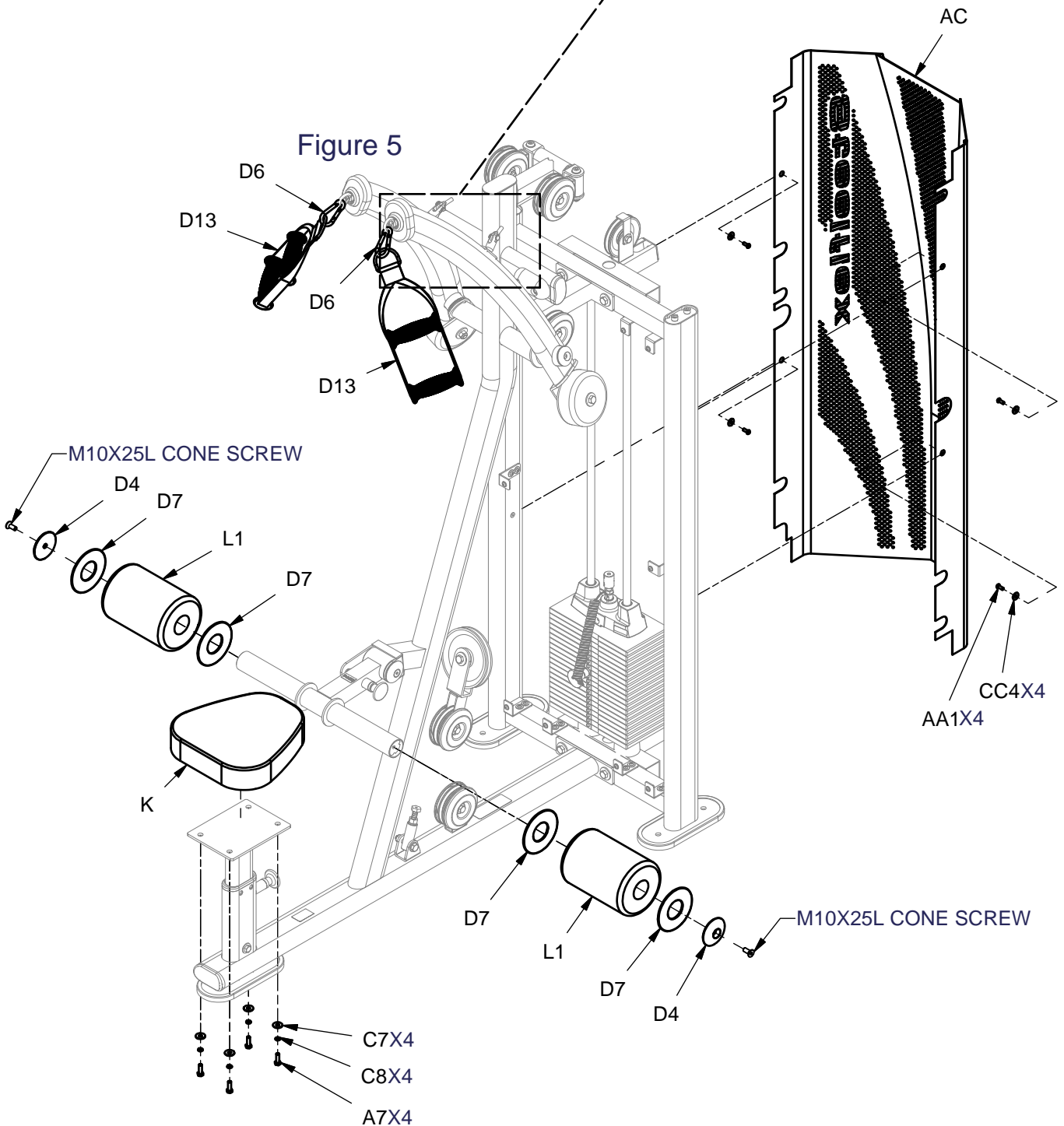
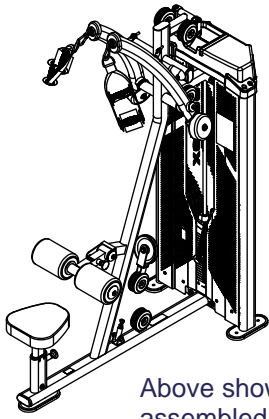

Figure 5



HLM-300 ASSEMBLY INSTRUCTIONS



Above shows STEP 10
assembled and completed

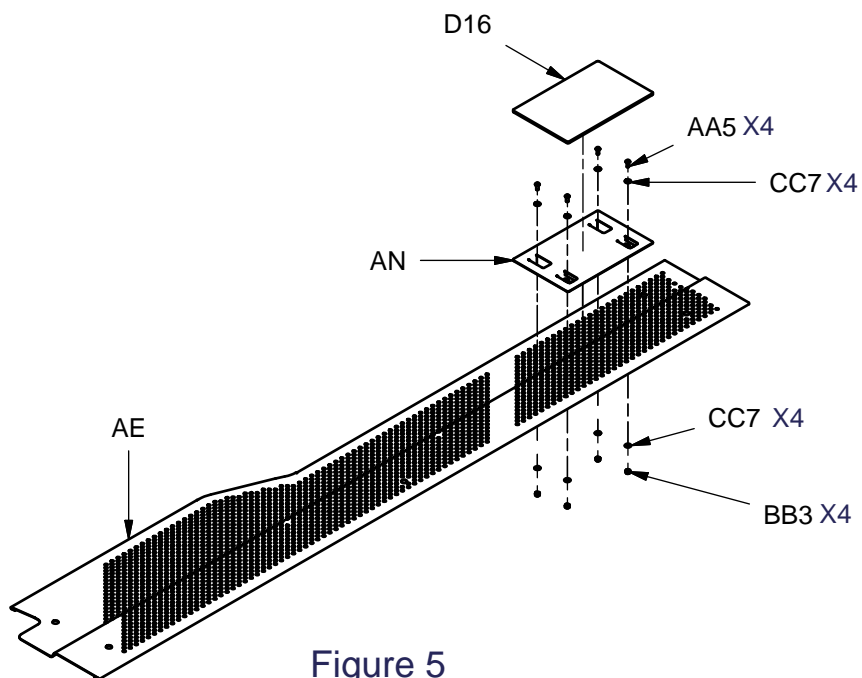
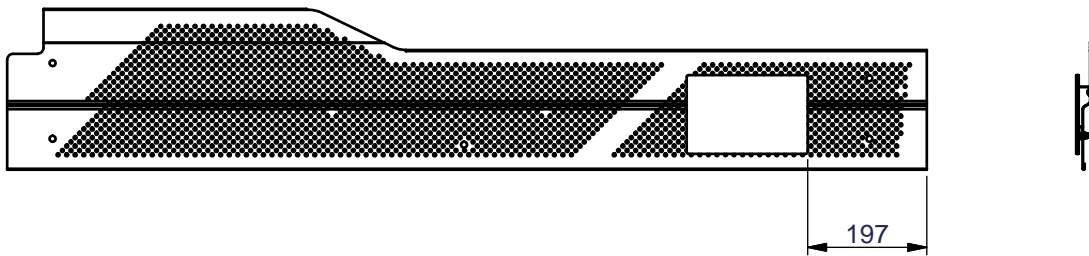
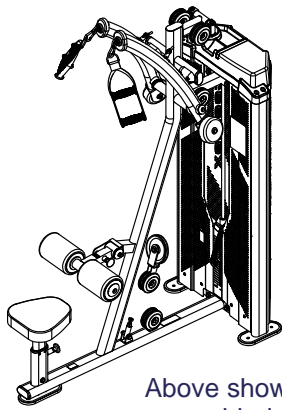
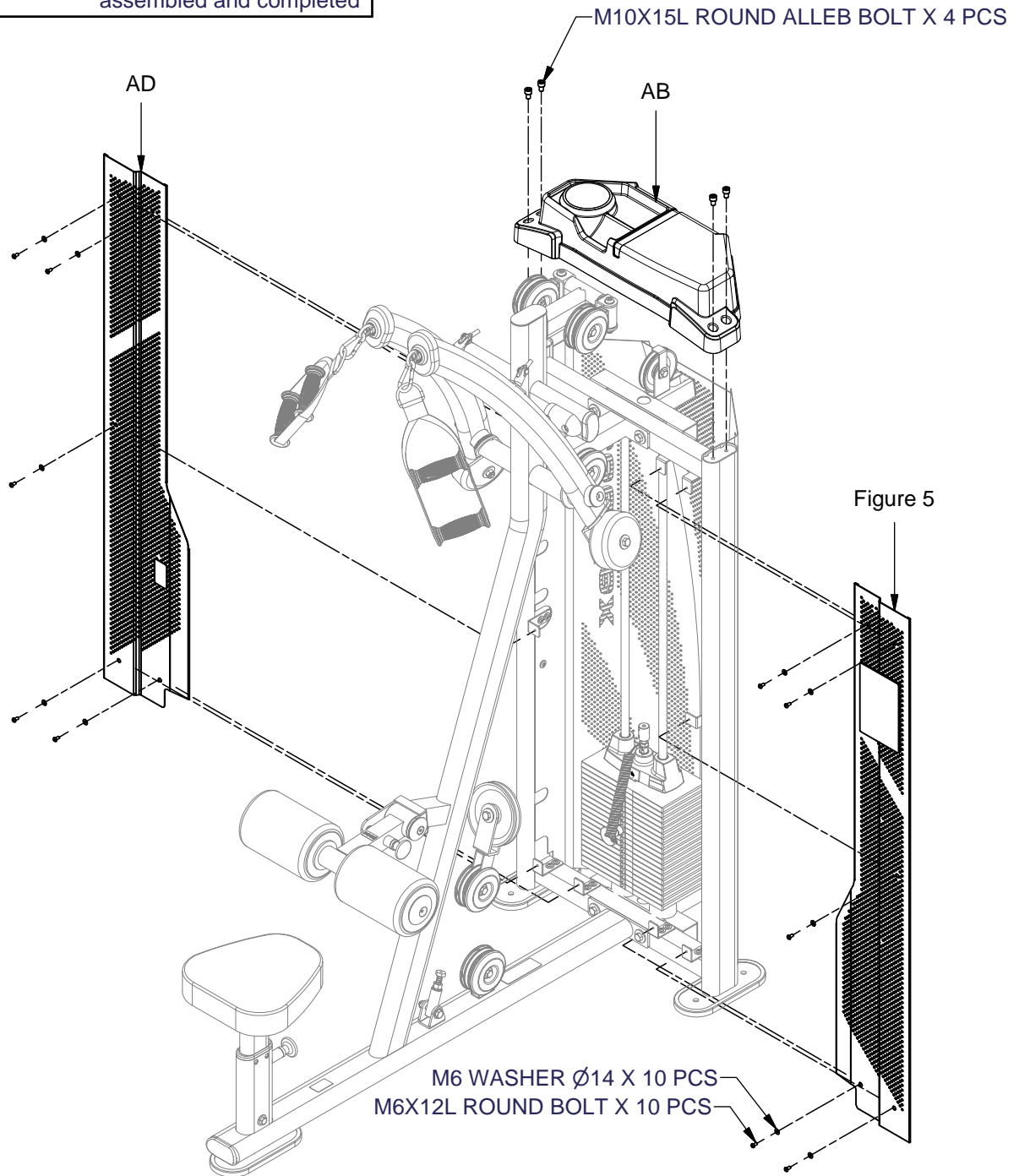

Figure 5

HLM-300 ASSEMBLY INSTRUCTIONS



Above shows STEP 11
assembled and completed



HOPE ASSEMBLY INSTRUCTIONS

DECAL REFERENCE

MAINTENANCE SCHEDULE		DAILY		WEEKLY	
Check the function and integrity of the following components. As noted, inspect equipment before each workout. Replace all damaged, broken or worn components immediately.					
Cables:	Check tension, end fittings, and coating	✓		✓	
	Check that locking nut at weight stack is tight		✓		✓
Upholstery:	Wipe down and dry	✓		✓	
	Clean and condition		✓		✓
Frame:	Wipe down and dry	✓		✓	
	Polish / Wax		✓		✓
Chrome:	Wipe down and dry	✓		✓	
	Polish / Lubricate		✓		✓
Nut / Bolts / Fasteners:	Tighten and / or adjust as needed		✓		✓
Guide Rods:	Lubricate and clean		✓		✓
Linear Rods:	Lubricate and clean		✓		✓
Seat Sleeves:	Lubricate and clean		✓		✓
Adjustments / Locking Pins / Tightening Knobs			✓		✓
Weight Stack Pins			✓		✓
Warning Instruction Labels			✓		✓
Springs / Pop Pins		✓			
Anti Skid Surfaces			✓		
Hand Grips / Rollers			✓		
For Steelflex Customer Service Call +886 2 27209980					

9440-258

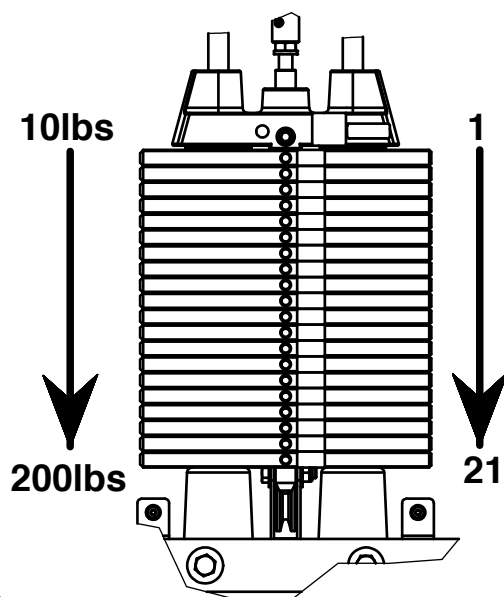

THERE IS A RISK ASSUMED BY INDIVIDUALS WHO USE THIS TYPE OF EQUIPMENT. TO MINIMIZE RISK, YOU MUST FOLLOW THESE RULES:

1. Inspect equipment before each workout. Check that all nuts, bolts, screws and pop pins are in place and fully tightened. Also, before use, check cables for signs of wear. Replace all worn parts immediately. Never use machine if any parts are damaged or missing. **FAILURE TO FOLLOW THESE RULES MAY RESULT IN SERIOUS INJURY.**
2. Keep clear of the cables and all moving parts when the machine is in use.
3. Always make sure all Snap Links are closed when doing any cable/pulley/strap exercises.
4. Exercise with care. Perform your exercises at a smooth moderate pace; never perform jerky or uncoordinated movements that may cause injury.
5. It is recommended that you should workout with a training partner.
6. Do not allow children or minors to play on or around this equipment.
7. If unsure of proper use of equipment, call Steelflex Customer Service +886 2 27209980.
8. **WARNING:** Consult your physician before starting your exercise program. For your own safety, do not begin any exercise program without proper instruction.

9440-259



9440-417

9440-418

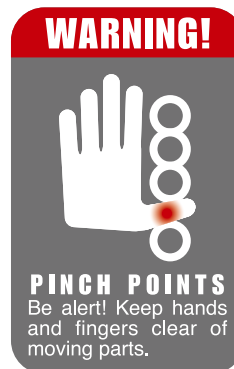

9440-117