

FUNCTION MACHINE

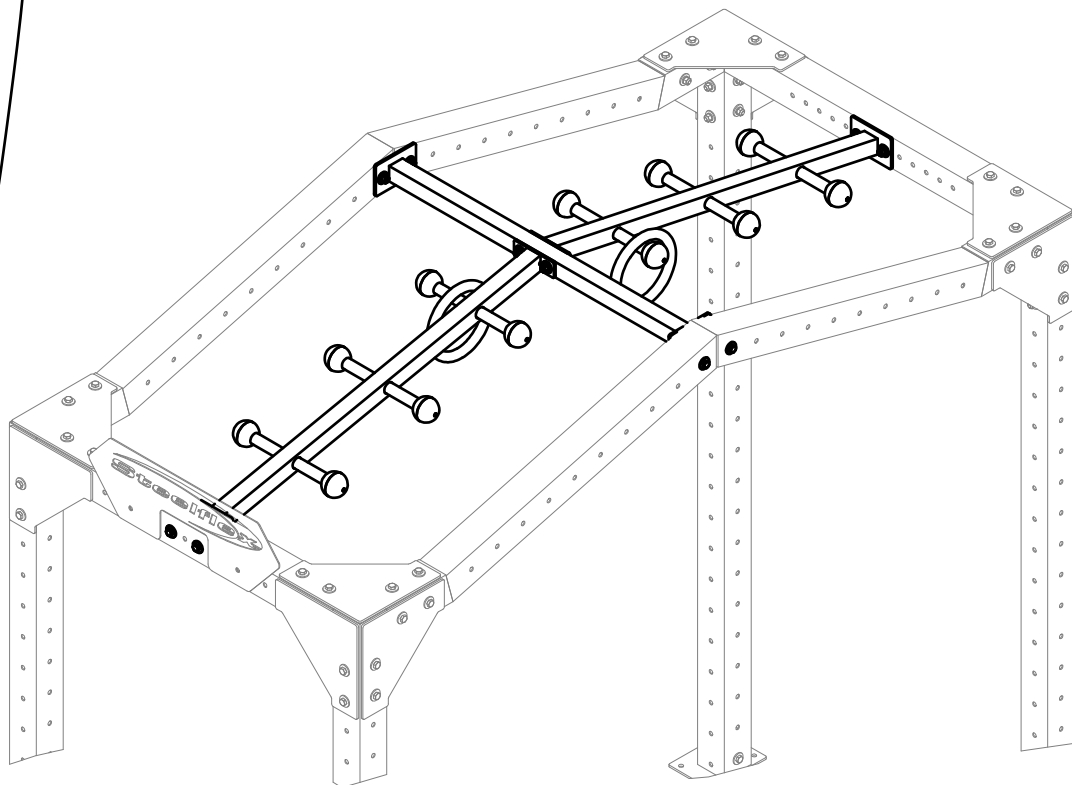

JOONG CHENN INDUSTRY CO., LTD.

Sales Office:

3F28, No.5, Shin-Yi Rd., Sec. 5, Taipei, Taiwan 110 R.O.C.

Tel: 886-2-27209980

Fax: 886-2-27229750

www.steelflexfitness.com

FMK4 OWNER'S MANUAL

FMK4 ASSEMBLY INSTRUCTIONS

HARDWARE ILLUSTRATION

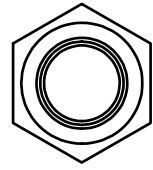
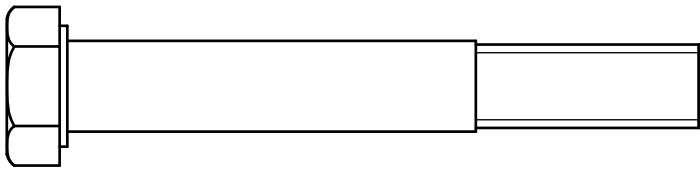

(A1)HEX BOLT M12X85L PARTIAL THREAD QTY.2

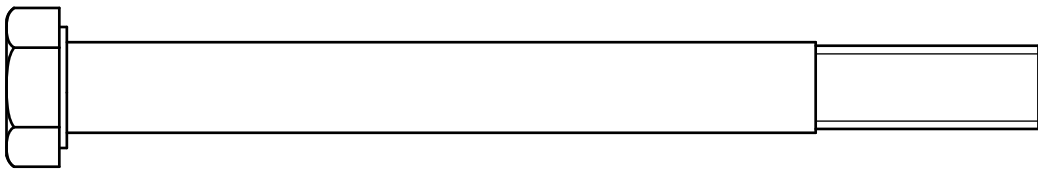

(A2)HEX BOLT M12X130L PARTIAL THREAD QTY.8

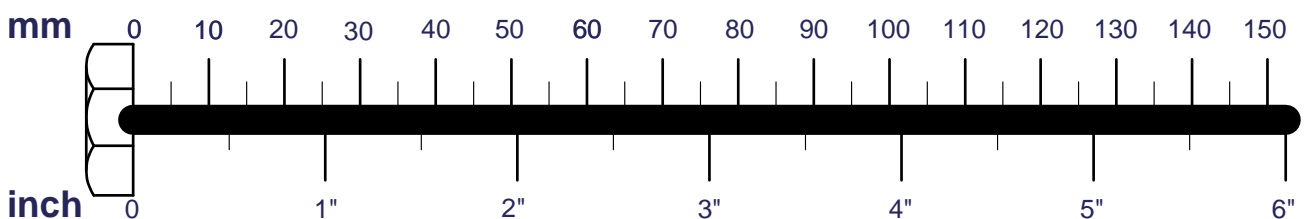

FMK4 ASSEMBLY INSTRUCTIONS

HARDWARE ILLUSTRATION

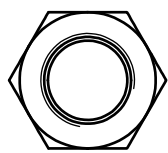

(B1)LOCK NUT M12 QTY.10

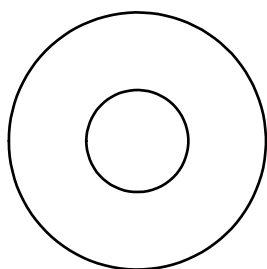

(C1)M12(I.D.)FLAT WASHER Ø34 QTY.20

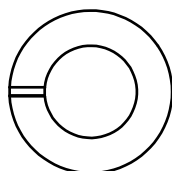

(C2)M12 SPRING WASHER QTY.10

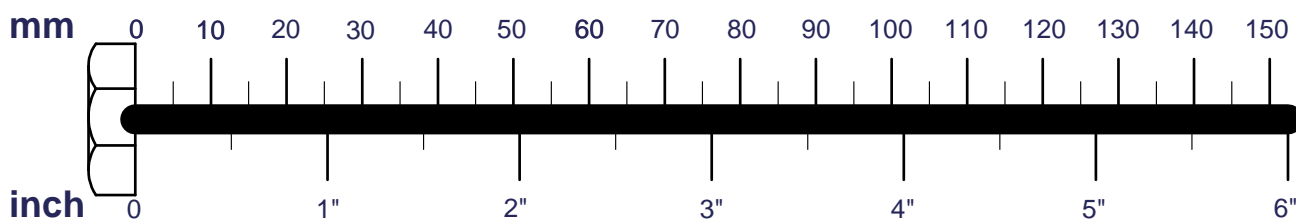

FMK4 ASSEMBLY INSTRUCTIONS

PARTS ILLUSTRATION SHEET

A[2PCS]

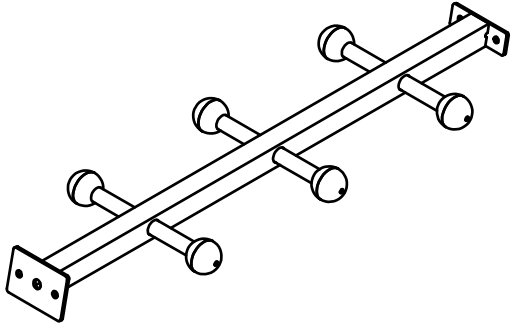

B[1PCS]

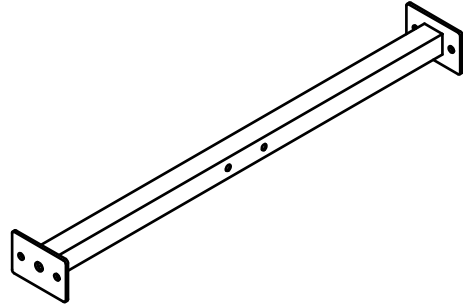

C[2PCS]
9630-319

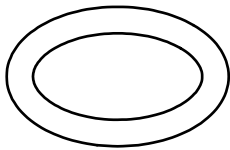

FMK4 ASSEMBLY INSTRUCTIONS

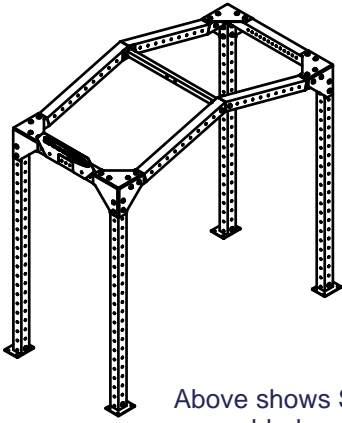

Please tighten the screw after all parts assembled.
or please tighten all screws after all parts joint together

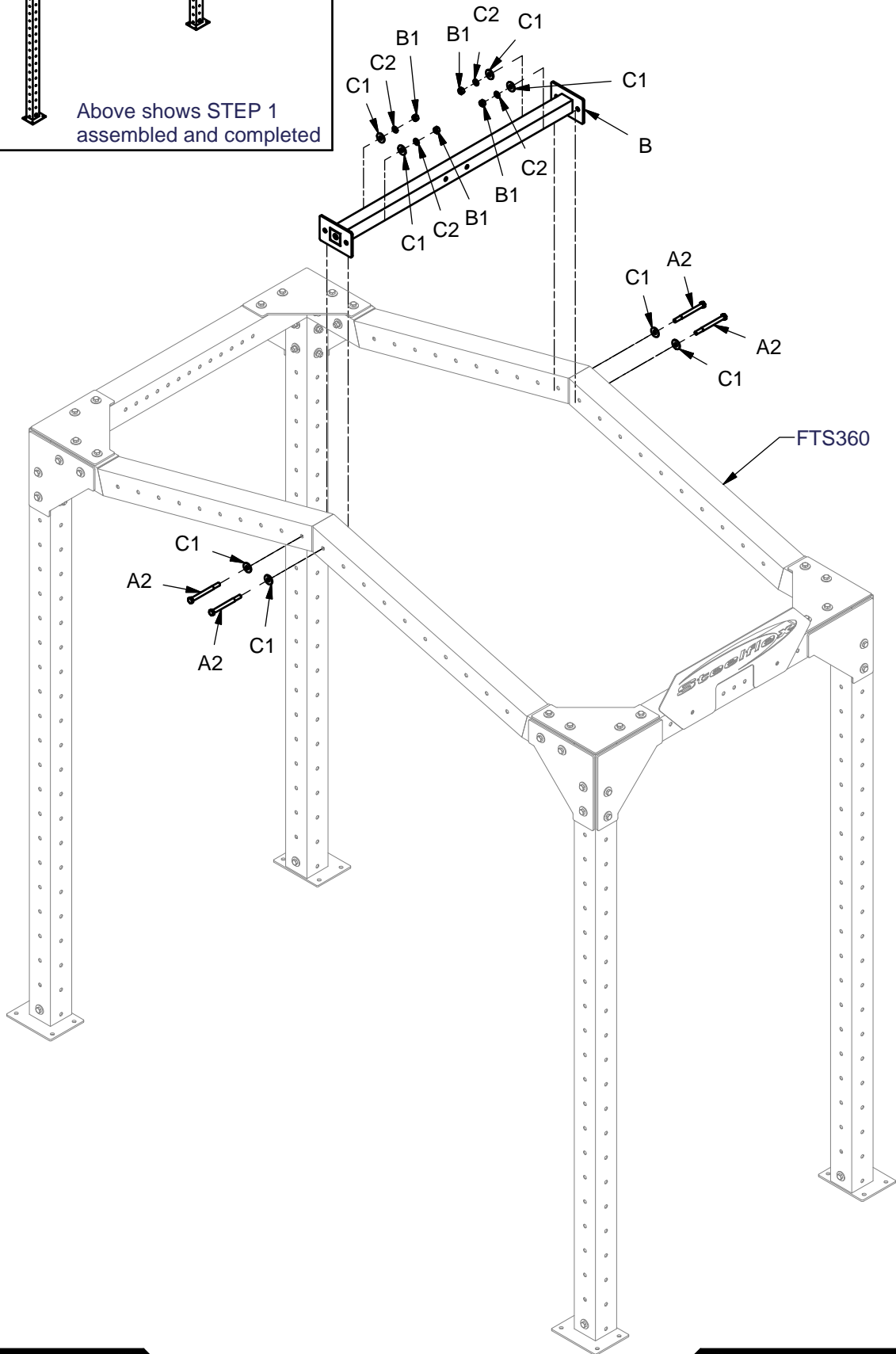

FMK4 ASSEMBLY INSTRUCTIONS

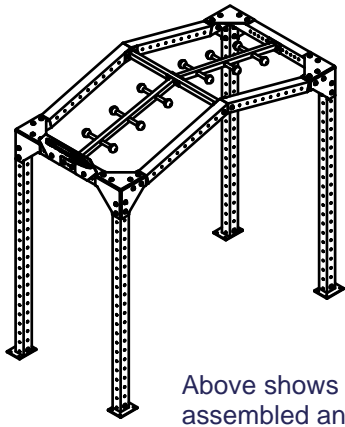

Above shows STEP 2 assembled and completed

