

THERE IS A RISK ASSUMED BY INDIVIDUALS WHO USE THIS TYPE OF EQUIPMENT. TO MINIMIZE RISK, YOU MUST FOLLOW THESE RULES:

1. Inspect equipment before each workout. Check that all nuts, bolts, screws and pop pins are in place and fully tightened. Also, before use, check cylinders for leaking. Replace all worn parts immediately. Never use machine if any parts are damaged or missing. Failure to follow these rules may result in serious injury.
2. Keep clear of the cylinder and all moving parts when the machine is in use.
3. Exercise with care. Perform your exercises at a smooth moderate pace; never perform jerky or uncoordinated movements that may cause injury.
4. It is recommended that you should workout with a training partner.
5. Do not allow children or minors to play on or around this equipment.
6. If unsure of proper use of equipment, call your local distributor.
7. **WARNING:** Consult your physician before starting your exercise program. For your own safety do not begin any exercise program without proper instruction.

CL2BT OWNER'S MANUAL

CL2BT ASSEMBLY INSTRUCTIONS

HARDWARE ILLUSTRATION

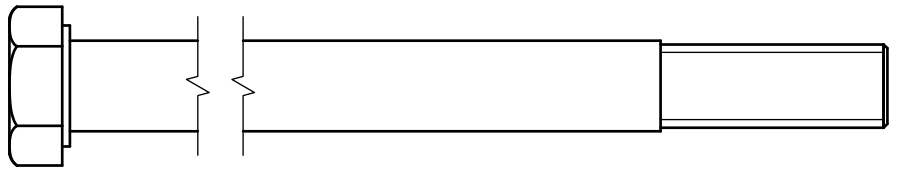
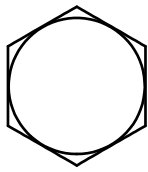

(A1)HEX BOLT M12X140L PARTIAL THREAD QTY.2

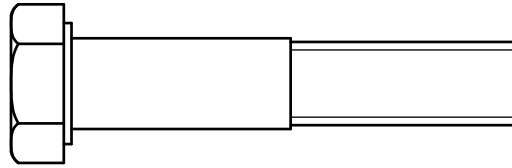
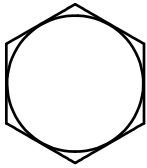

(A2)HEX BOLT M12X60L PARTIAL THREAD QTY.1

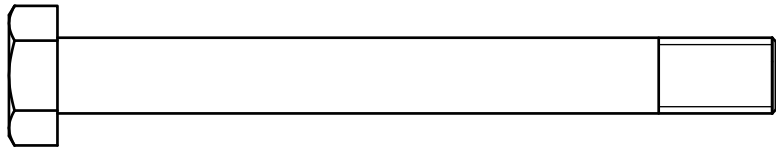
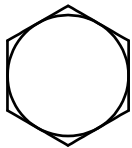

(A3)HEX BOLT M10X95L PARTIAL THREAD QTY.1

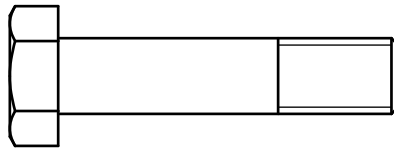
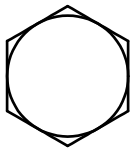

(A4)HEX BOLT M10X45L PARTIAL THREAD QTY.1

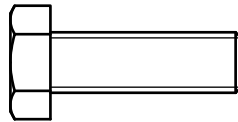
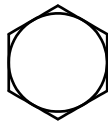

(A5)HEX BOLT M8X25L PARTIAL THREAD QTY.12

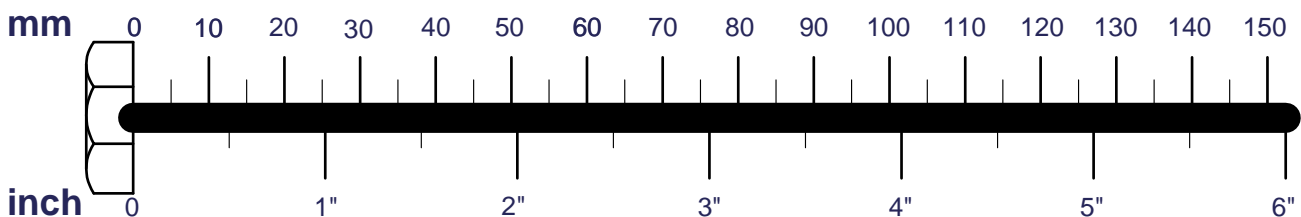

HARDWARE ILLUSTRATION

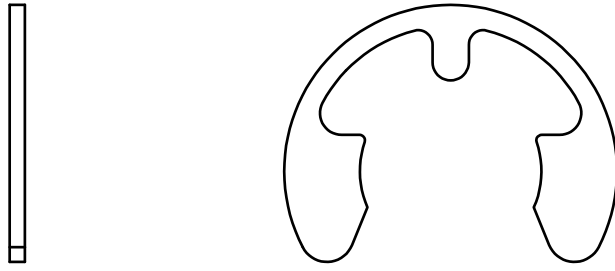

(A6)E TYPE BUCKLE Ø24 QTY.1

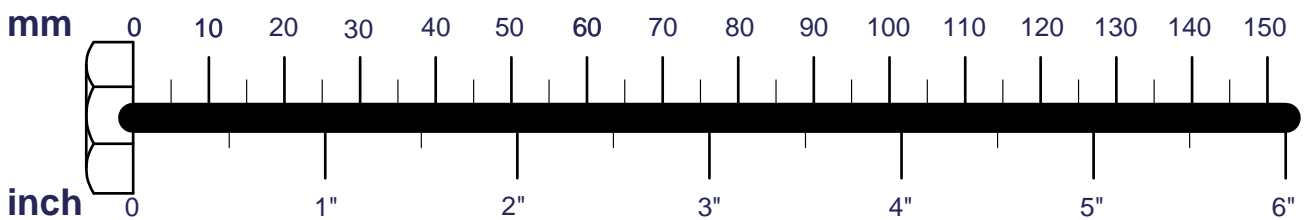

CL2BT ASSEMBLY INSTRUCTIONS

HARDWARE ILLUSTRATION

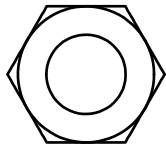

(B1) NYLON LOCK NUT M12 QTY.3

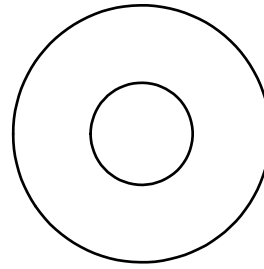

(C1) M12 (I.D.) FLAT WASHER Ø34 QTY.6

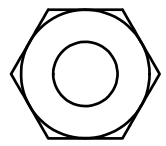

(B2) NYLON LOCK NUT M10 QTY.2

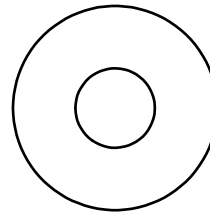
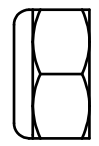

(C2) M10 (I.D.) FLAT WASHER Ø27 QTY.4

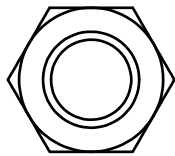

(B3) LOCK NUT 1/2"-13UNC QTY.1

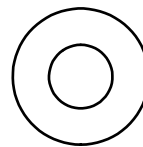
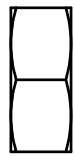

(C3) M8 (I.D.) FLAT WASHER Ø18 QTY.12



(C4) SPRING WASHER M8 QTY.12

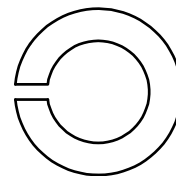

(C5) SPRING WASHER 1/2" QTY.1

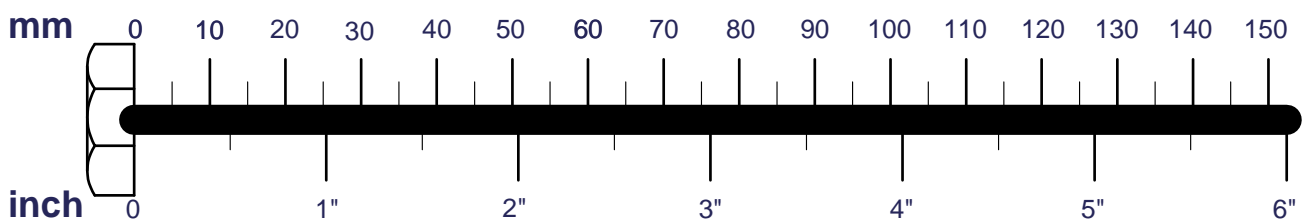

CL2BT ASSEMBLY INSTRUCTIONS

FRAME HARDWARE ILLUSTRATION

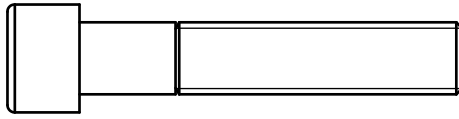
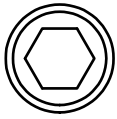

(AA1) ROUND ALLEN HEAD 3/8"x2"L PARTIAL QTY.1

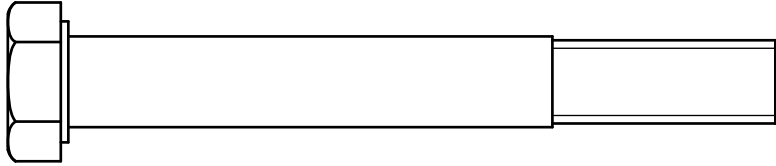
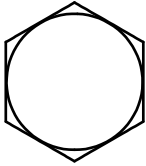

(AA2)HEX BOLT M12X95L PARTIAL THREAD QTY.2

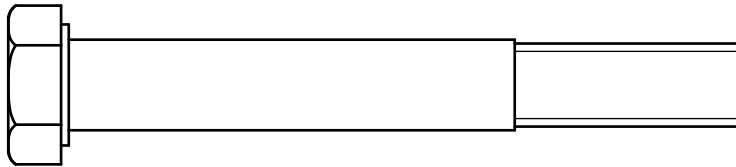
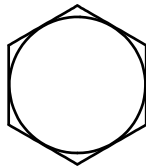

(AA3)HEX BOLT M12X90L PARTIAL THREAD QTY.2

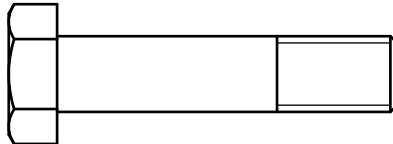
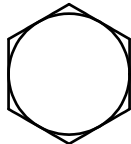

(AA4)HEX BOLT M10X45L PARTIAL THREAD QTY.3

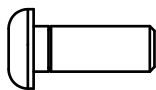

(AA5)ROUND INNER HEX SCREW M6x16L PARTIAL THREAD QTY.4

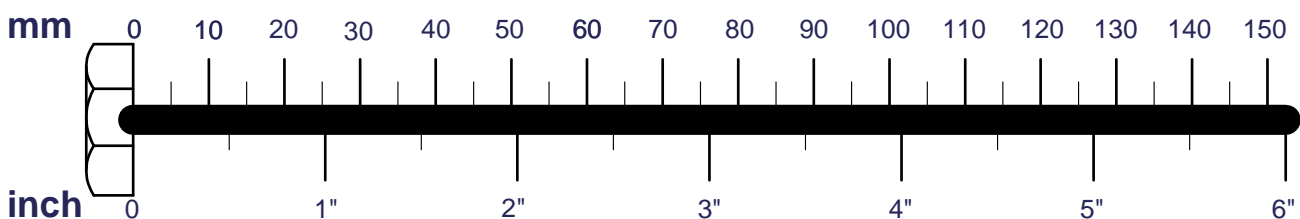

CL2BT ASSEMBLY INSTRUCTIONS

FRAME HARDWARE ILLUSTRATION

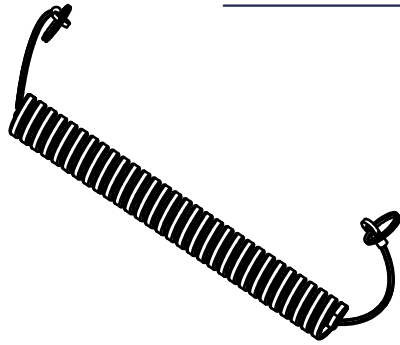

(AA6)ELASTIC BELT F920003 QTY.1

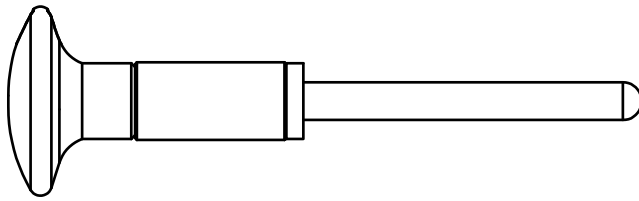

(AA7)10LB PIN(8250-128) QTY.1



(AA8)ROUND INNER HEX SCREW M4x12L PARTIAL THREAD QTY.2

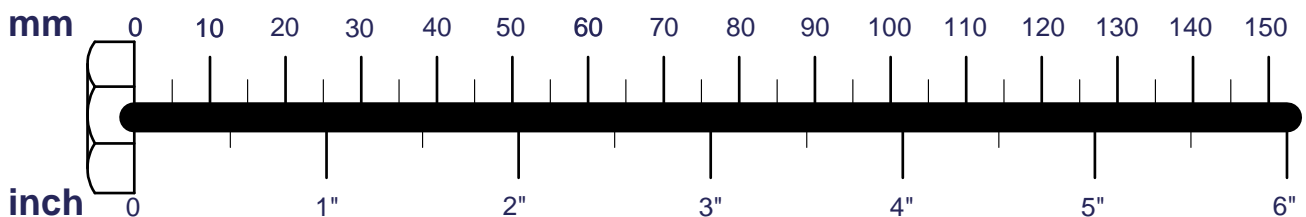

CL2BT ASSEMBLY INSTRUCTIONS

FRAME HARDWARE ILLUSTRATION

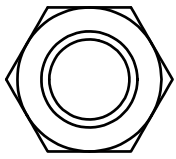

(BB1) LOCK NUT 1/2"-13UNC QTY.1

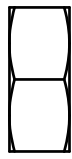

(BB2) NYLON LOCK NUT M12 QTY.4

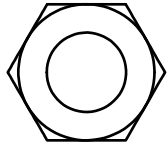

(BB3) NYLON LOCK NUT M10 QTY.3



(BB4) NYLON LOCK NUT M4 QTY.2

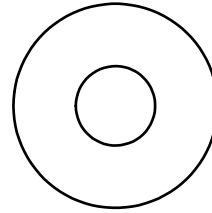

(CC2) M10(I.D.) FLAT WASHER Ø27 QTY.6

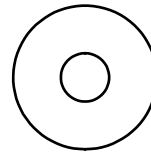

(CC3) M6(I.D.) FLAT WASHER Ø19 QTY.4

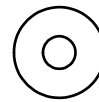

(CC4) M4(I.D.) FLAT WASHER Ø12 QTY.4

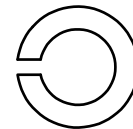

(CC5) SPRING WASHER 3/8" QTY.1

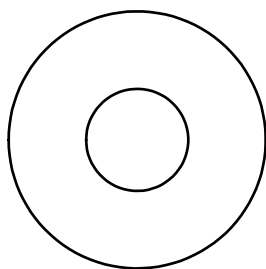

(CC1) M12(I.D.) FLAT WASHER Ø34 QTY.8

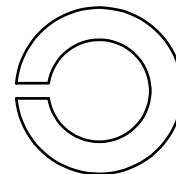

(CC6) SPRING WASHER 1/2" QTY.1

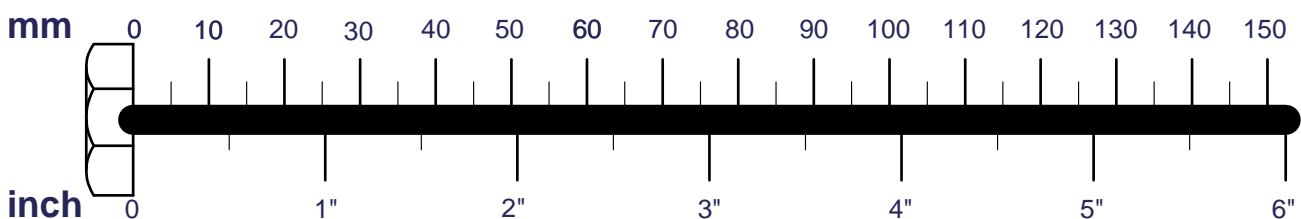

CL2BT ASSEMBLY INSTRUCTIONS

HARDWARE ILLUSTRATION

| | |
|---|--------|
| D1.Ø38XØ25.2X15L STEEL BUSHING(8130-430)----- | [1PCS] |
| D2.Ø1"X70L STEEL BUSHING(8220-244)----- | [1PCS] |
| D3.Ø38XØ26X1.5t CU WSAHER(8520-008)----- | [4PCS] |
| D4.Ø116X17 CAP COVER(9211-173)----- | [2PCS] |
| D5.Ø1" RUBBER PAD(9212-019)----- | [1PCS] |
| D6.Ø110X22 PULLEY (9213-002B)----- | [3PCS] |
| D7.3985mm STEEL CABLE(FCL2BT)----- | [1PCS] |

D1.



D2.

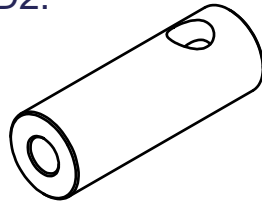

D3.

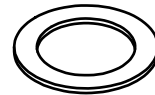

D4.

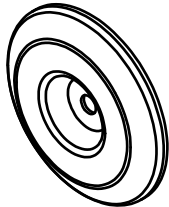

D5.

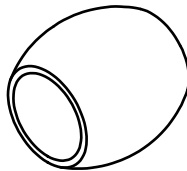

D6.

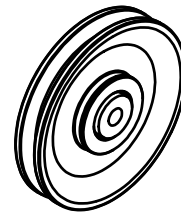

D7.

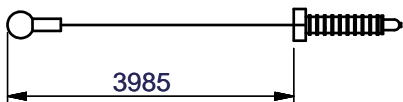

D8.

D9.

CL2BT ASSEMBLY INSTRUCTIONS

FARME HARDWARE ILLUSTRATION

| | |
|--|--------|
| DD1.Ø3/4" SHAFT COLLAR(9211-046)----- | [2PCS] |
| DD2.50X4tX50L RUBBER PAD(9214-002)----- | [1PCS] |
| DD3.Ø21/2"XØ19.2X19.4L RUBBER DOUNT(9310-010)----- | [2PCS] |
| DD4.108X14.5tX263L RUBBER PAD(9310-115)----- | [2PCS] |
| DD5.Ø110X22 PULLEY (9213-002B)----- | [3PCS] |
| DD6.BOTTLE BRACKET(8388-025)----- | [1PCS] |
| DD7.BOTTLE RACK(9260-320)----- | [1PCS] |
| DD8.BOTTLE(9260-123)----- | [1PCS] |

DD1.



DD2.

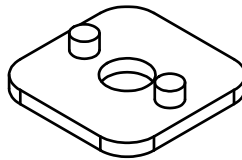

DD3.

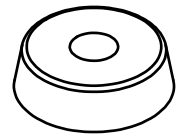

DD4.

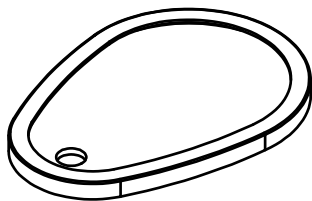

DD5.

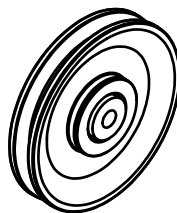

DD6.

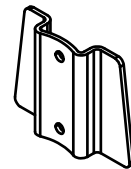

DD7.

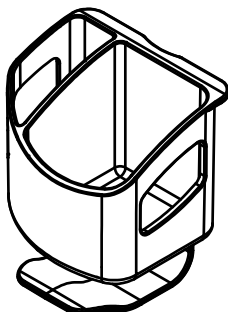

DD8.



CL2BT ASSEMBLY INSTRUCTIONS

PARTS ILLUSTRATION SHEET

A [1SET]

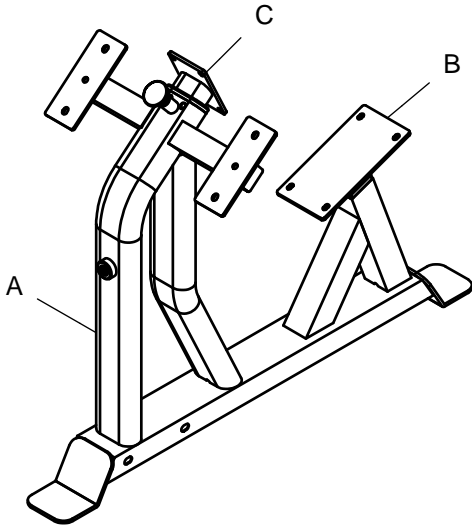

D [1SET]

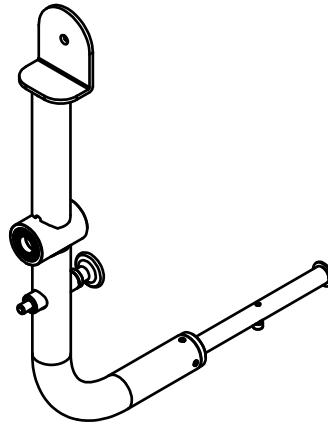

E [1SET]

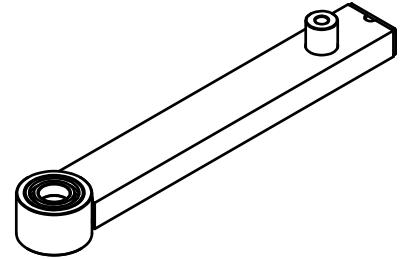

F [1SET]

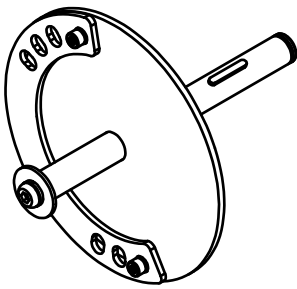

G [1SET]

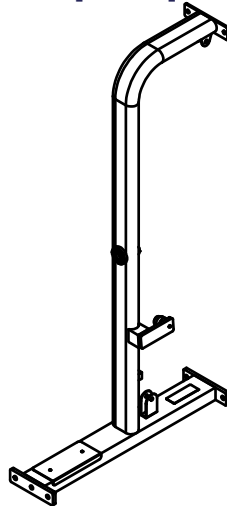

H [1SET]

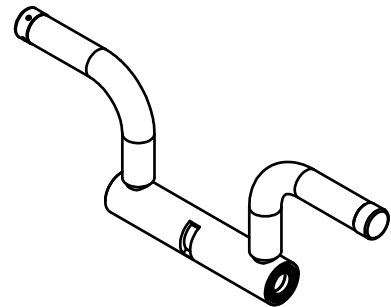

I [1SET]

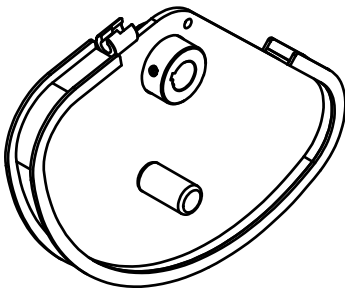

J [1SET]

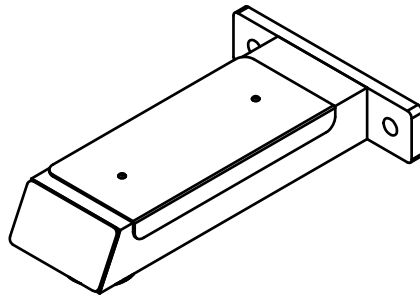

M [1SET]

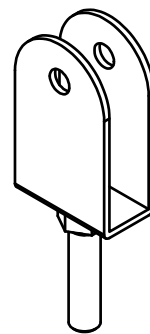

PARTS ILLUSTRATION SHEET

O [1SET]
8343-065

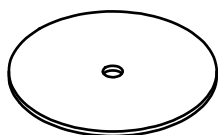

P [1SET]
9121-118

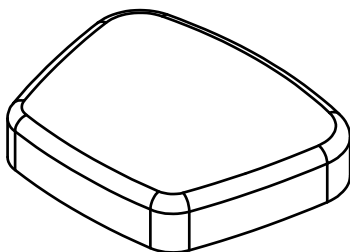

Q [1SET]
9131-026

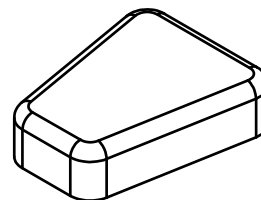

R [2SET]
9131-070

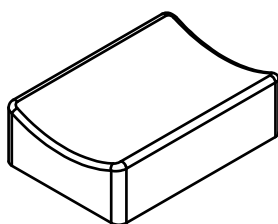

S [1PCS]
9420-134

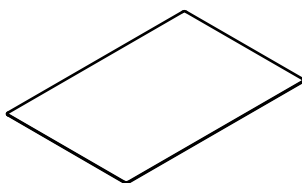

T [1SET]
8230-027

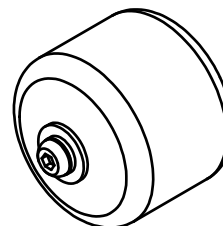

U [1PCS]
9211-205

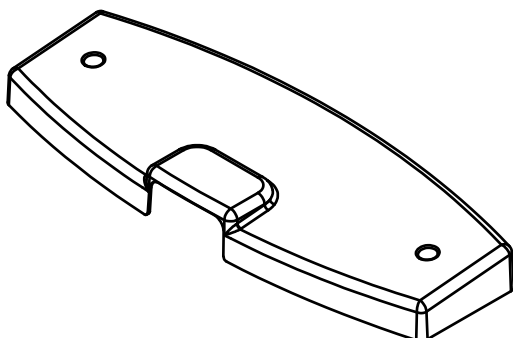

CL2BT ASSEMBLY INSTRUCTIONS

FARME PARTS ILLUSTRATION SHEET

AA [1SET]
6610-040

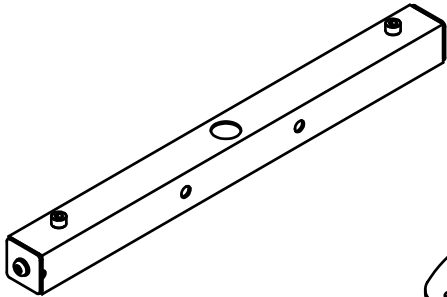

AB [1SET]
6610-041

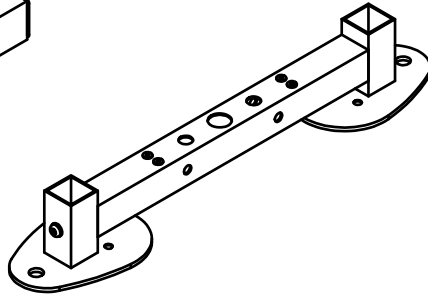

AC [1SET]
20CL2BT-N

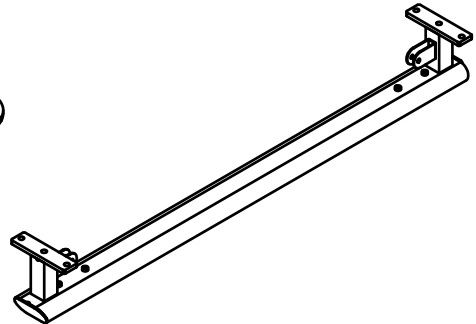

AD [1PCS]
8380-082

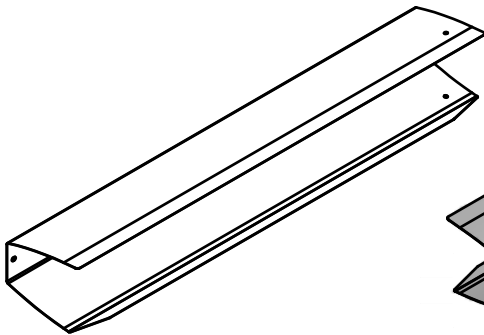

AE [1SET]
8380-083

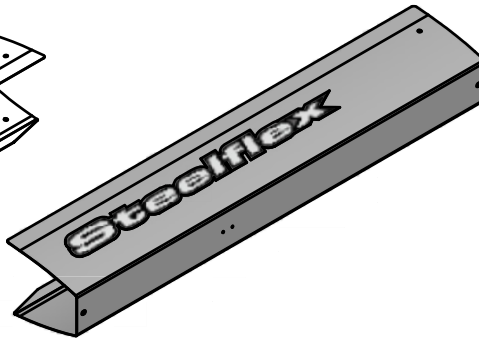

AF [2SET]
6670-005

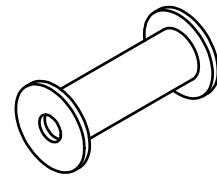

AG [1SET]
8400-006

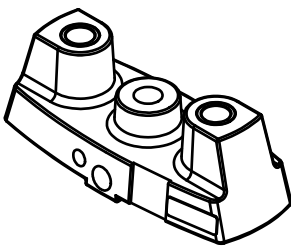

AH [1SET]
8210-042
3/4"X596L

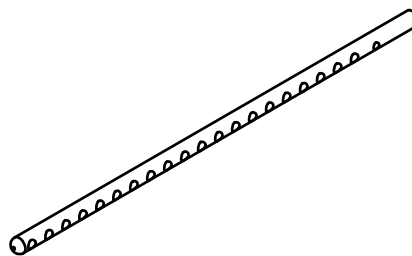

AI [2SET]
8321-066

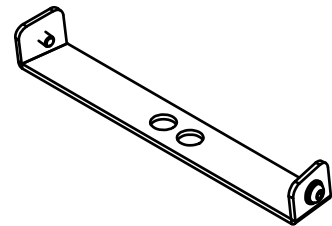

AJ [2SET]
8280-037
Ø3/4"X1522L

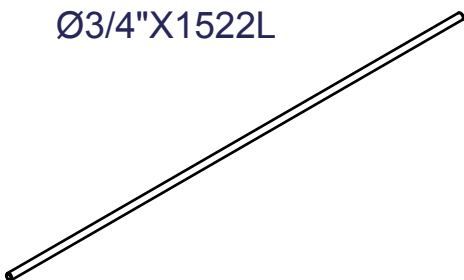

CL2BT ASSEMBLY INSTRUCTIONS

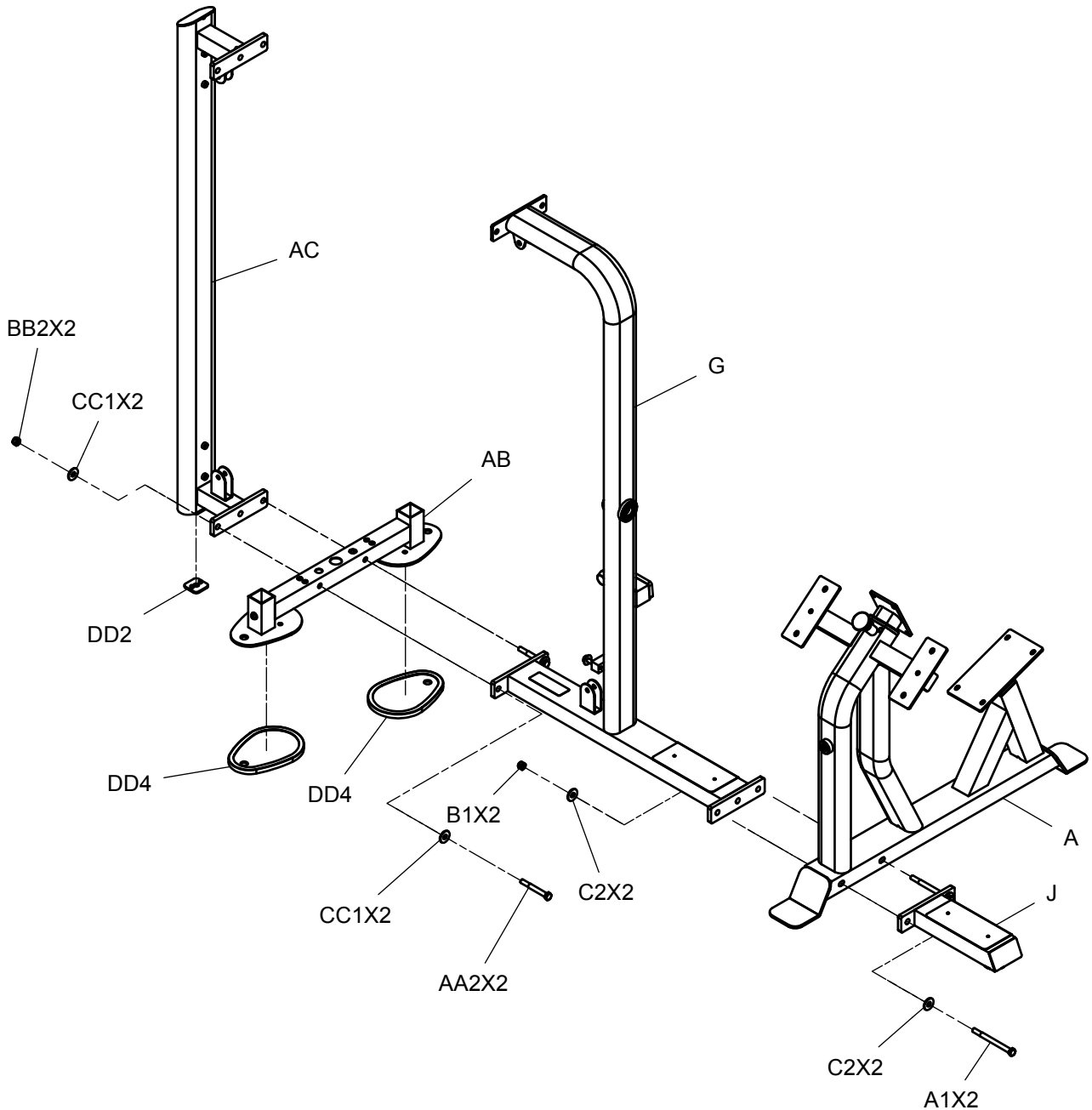
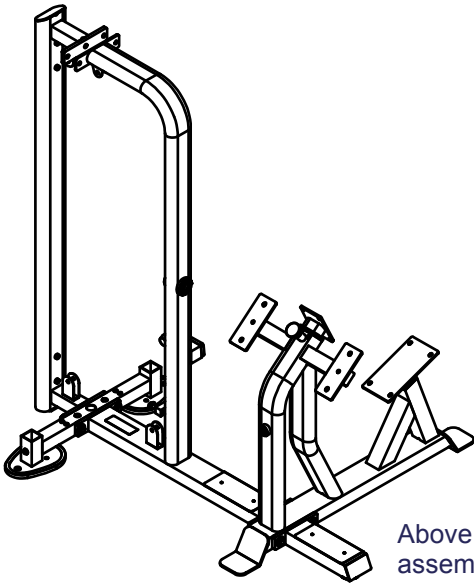

CL2BT ASSEMBLY INSTRUCTIONS

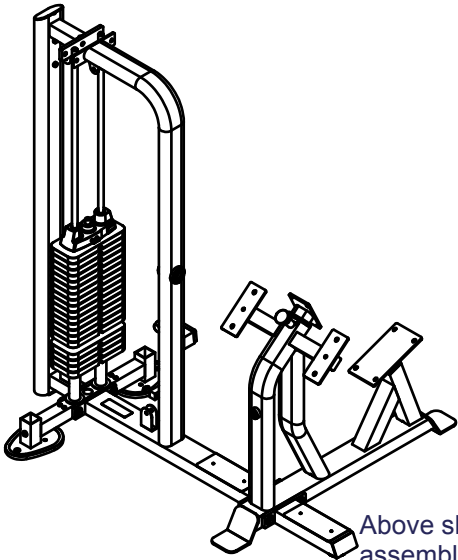

Above shows STEP 2 assembled and completed

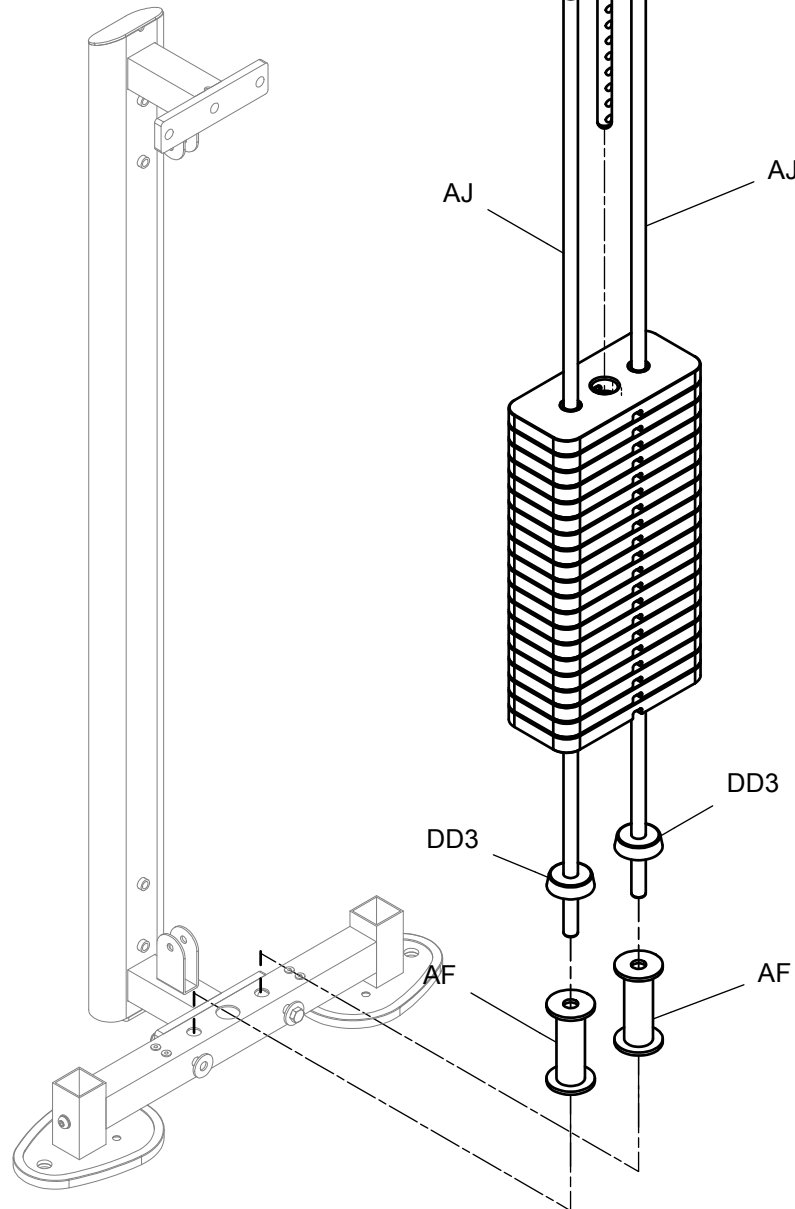
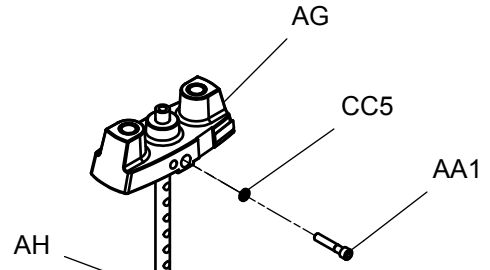

CL2BT ASSEMBLY INSTRUCTIONS

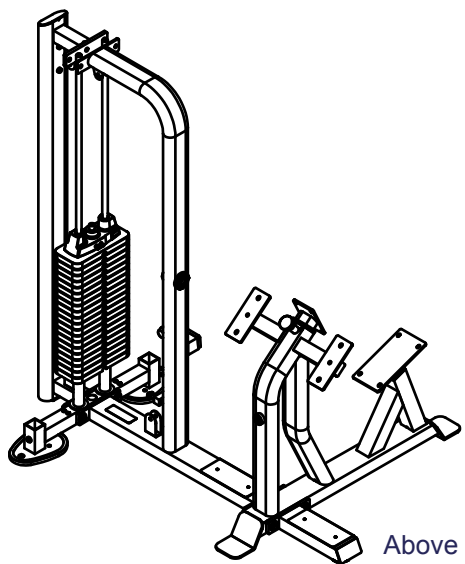

Above shows STEP 3 assembled and completed

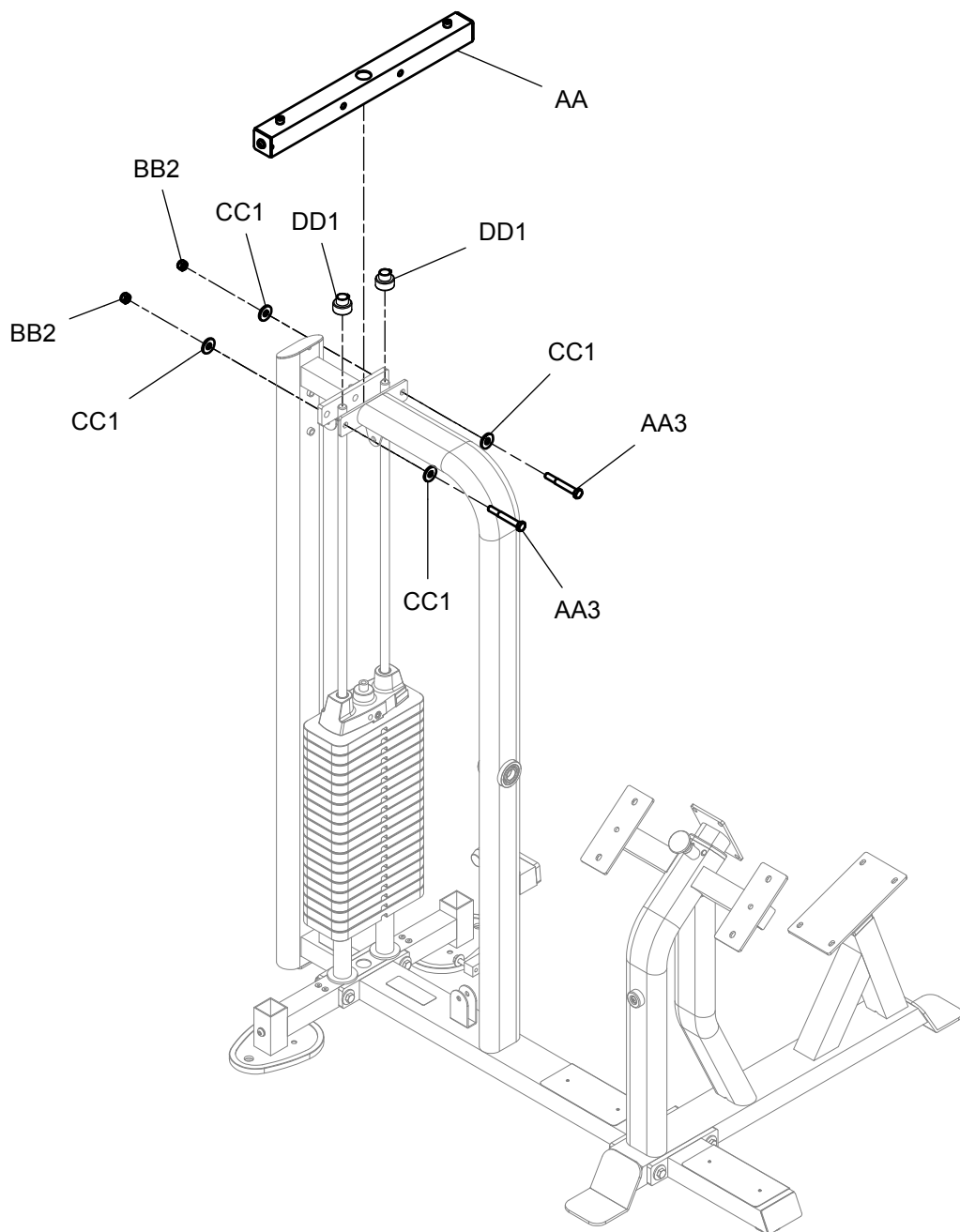

CL2BT ASSEMBLY INSTRUCTIONS

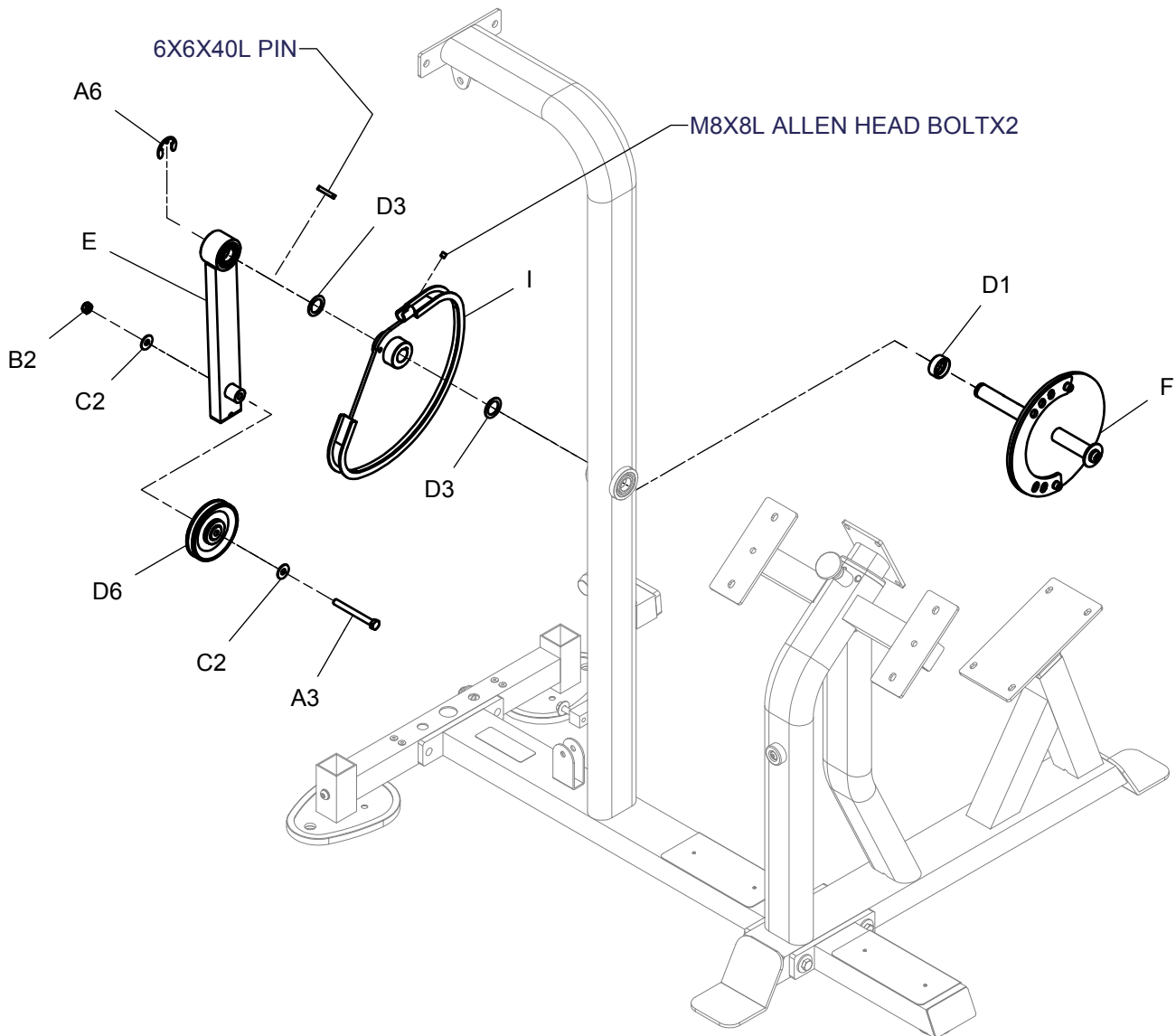
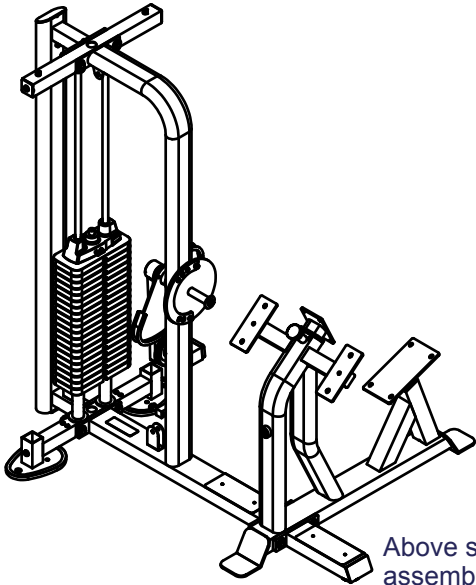

CL2BT ASSEMBLY INSTRUCTIONS

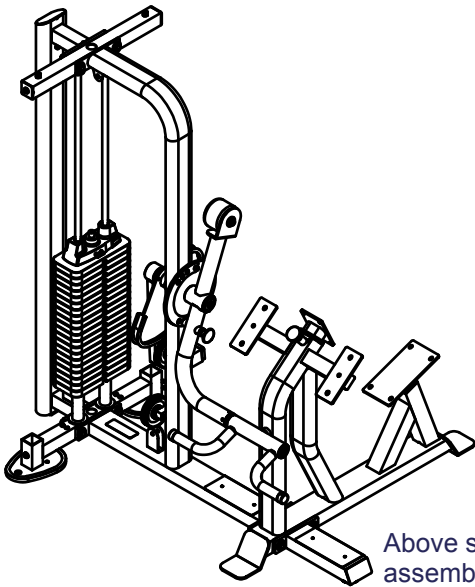

Above shows STEP 6 assembled and completed

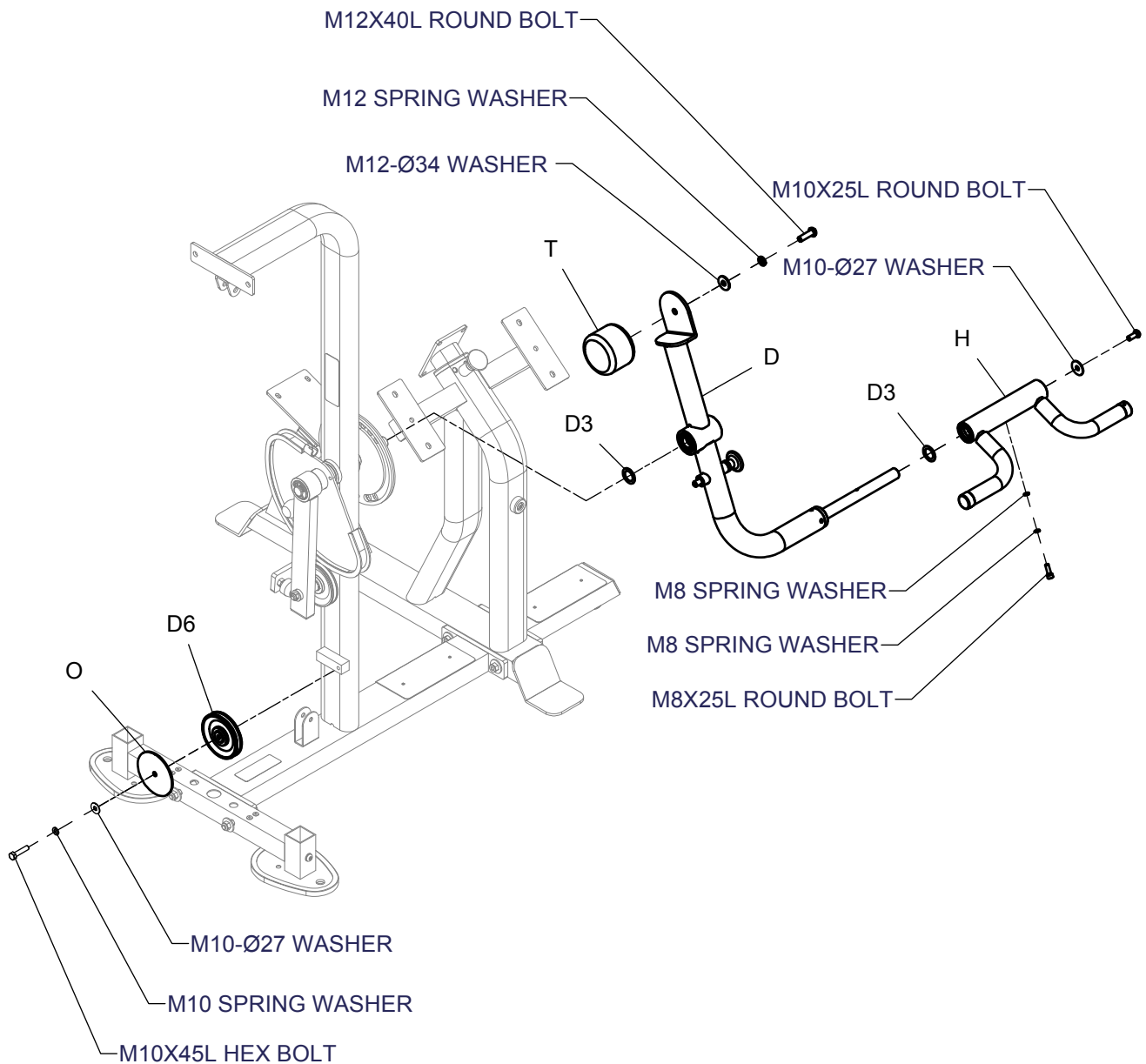

CL2BT ASSEMBLY INSTRUCTIONS

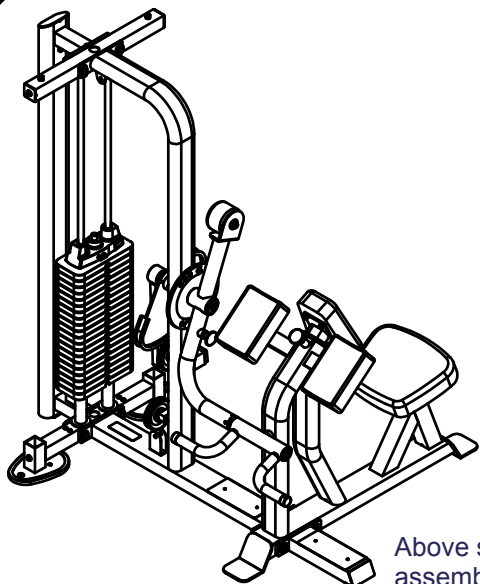

Above shows STEP 6 assembled and completed

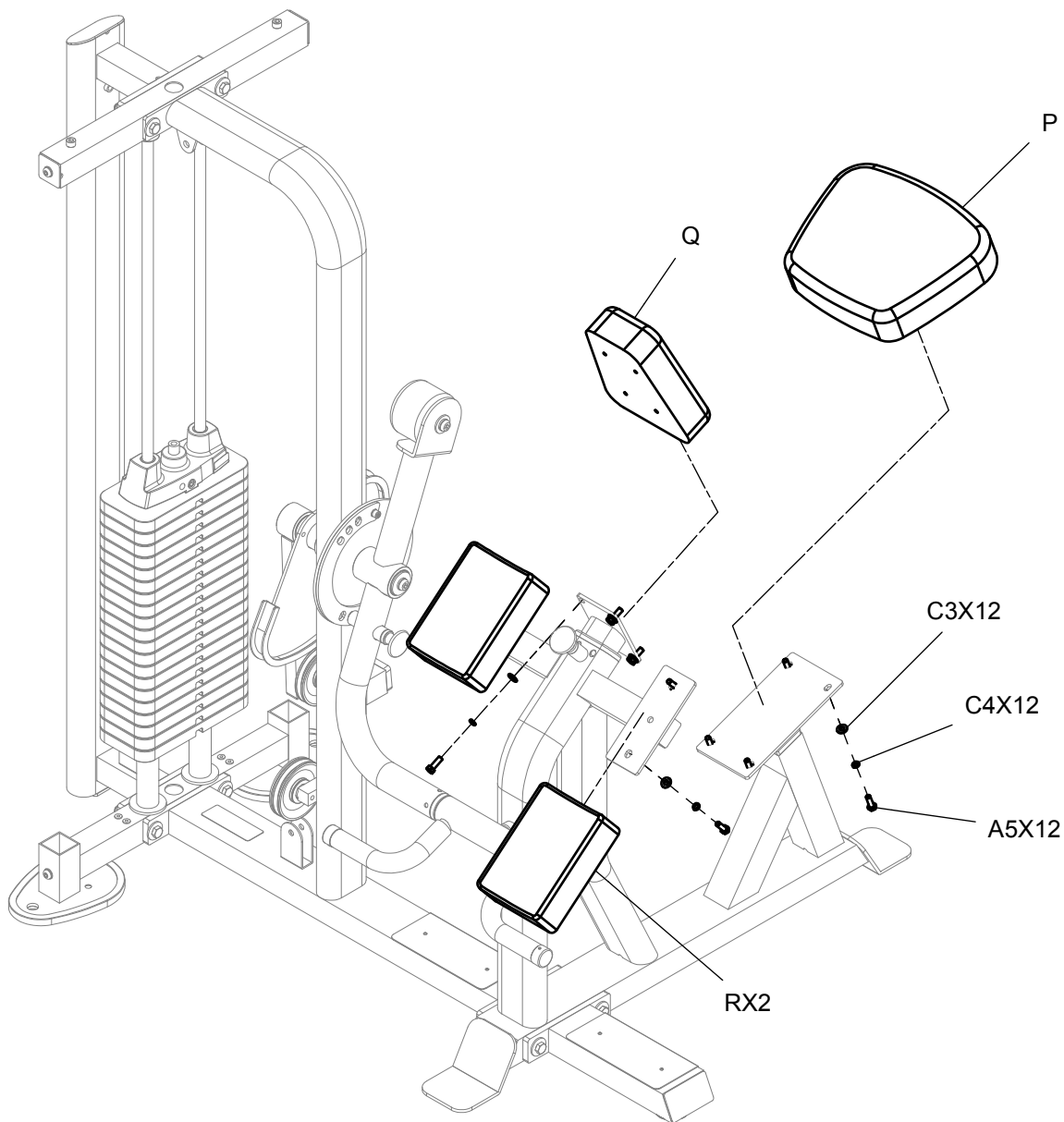

CL2BT ASSEMBLY INSTRUCTIONS

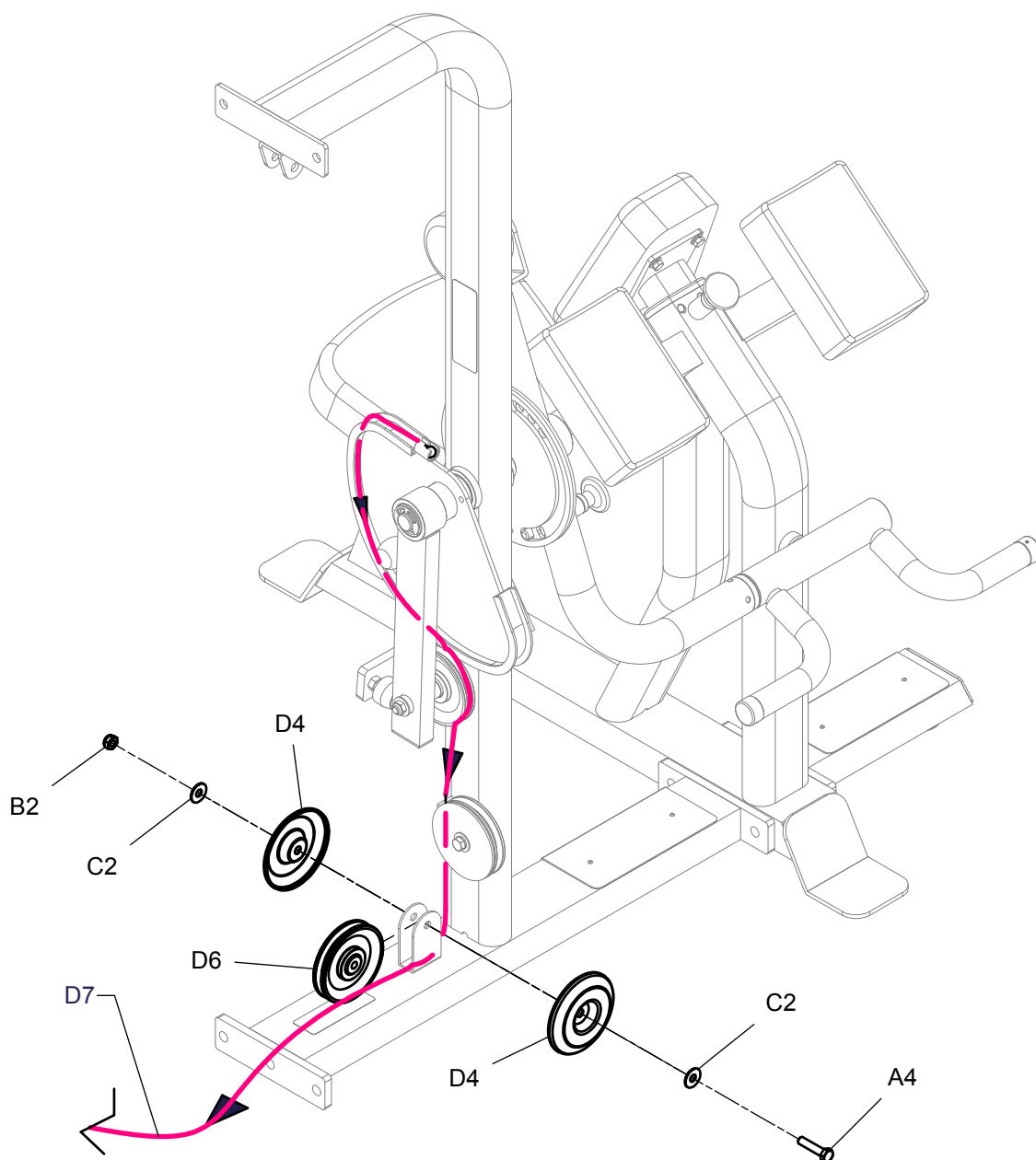
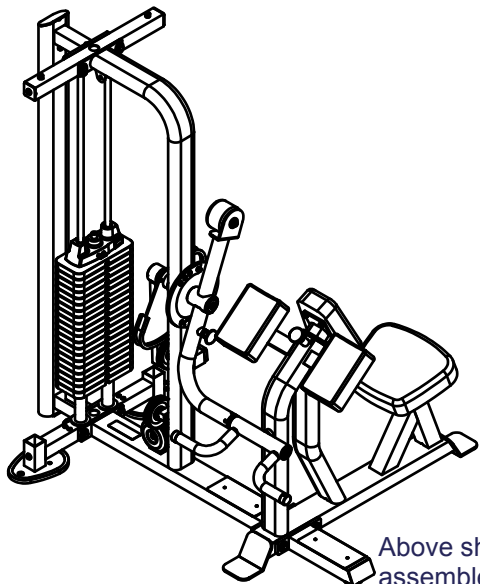

CL2BT ASSEMBLY INSTRUCTIONS

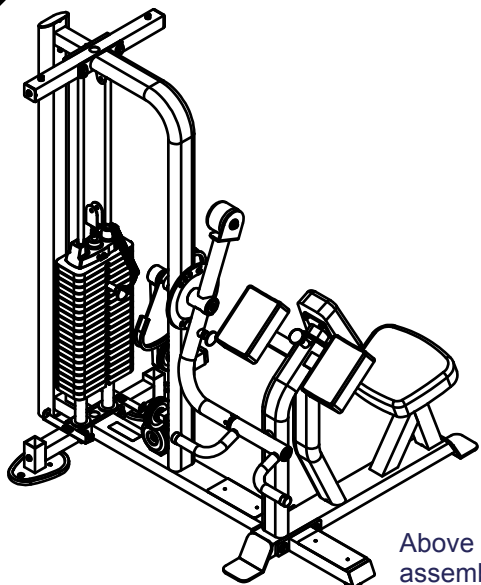

Above shows STEP 7
assembled and completed

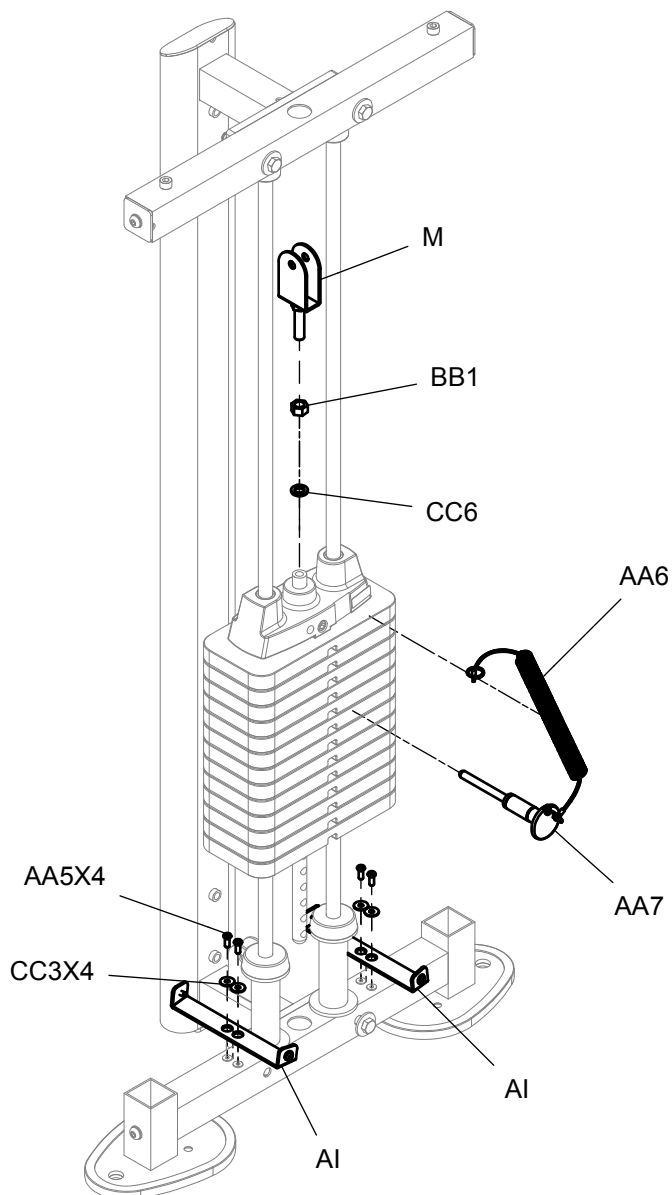

CL2BT ASSEMBLY INSTRUCTIONS

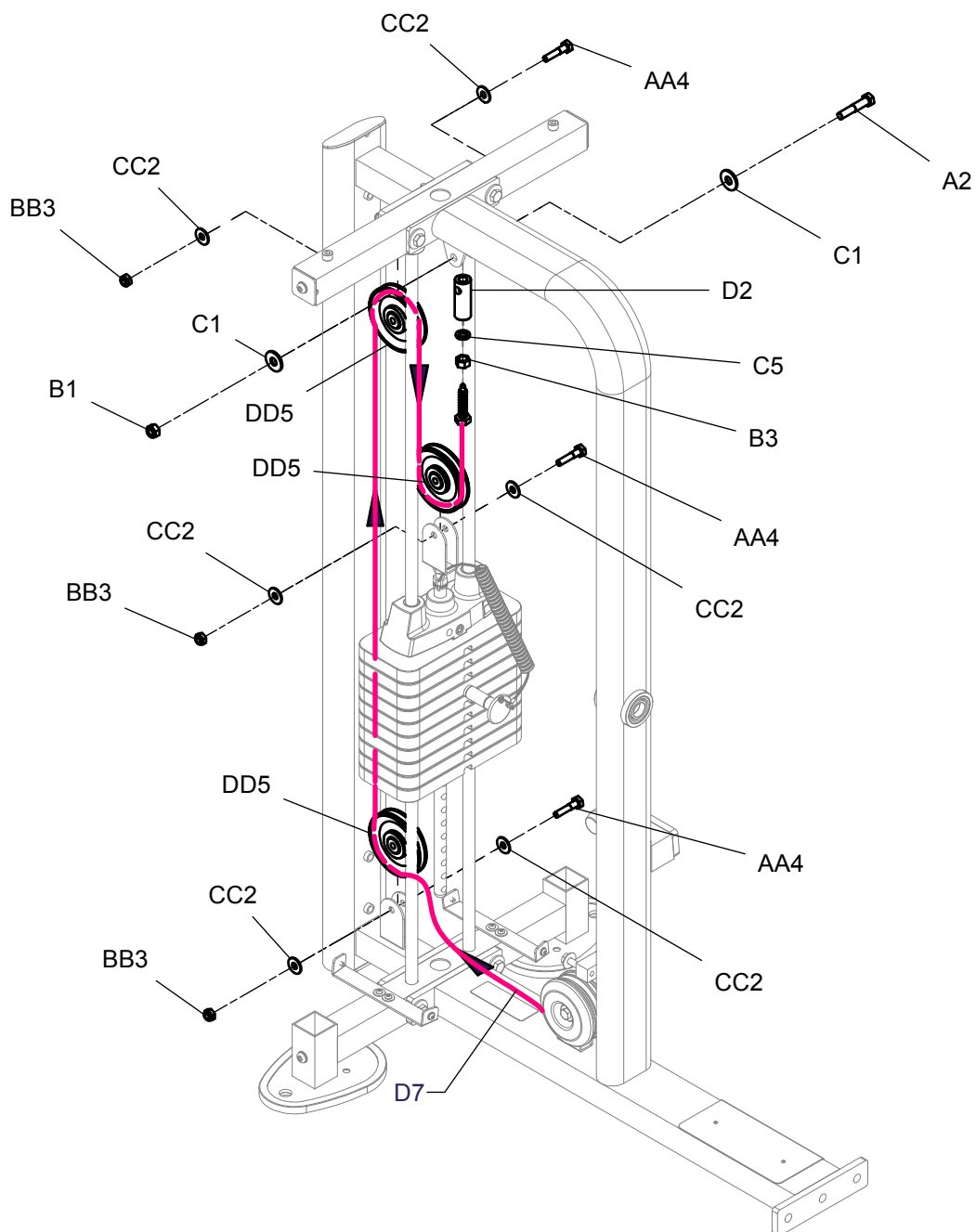
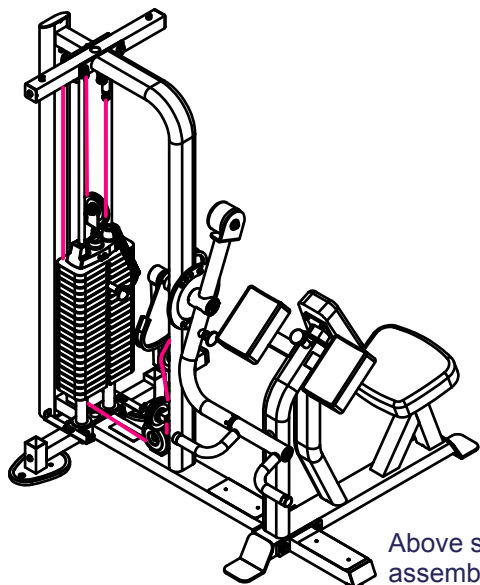

CL2BT ASSEMBLY INSTRUCTIONS

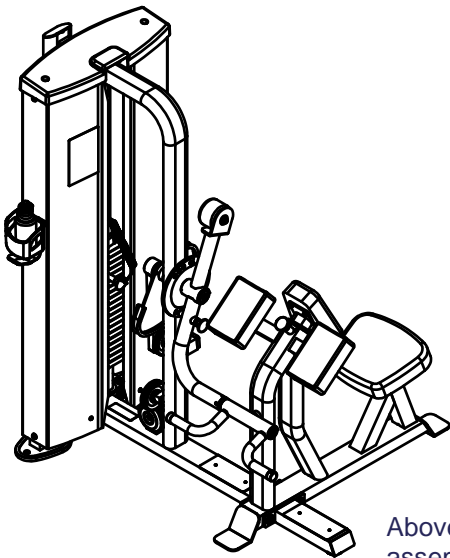

Above shows STEP 8 assembled and completed

