

* PLTR Maintenance



* Customers can put some grease on pivot points (red circle place), with brass or gunmetal bushings.



WD-40多种规格



* Let's maintain your machine!

PLTR.5 PARTS

A [1PCS]

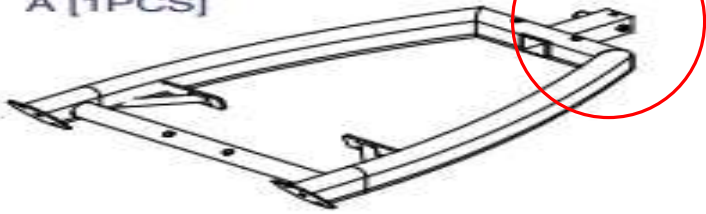

B [1PCS]

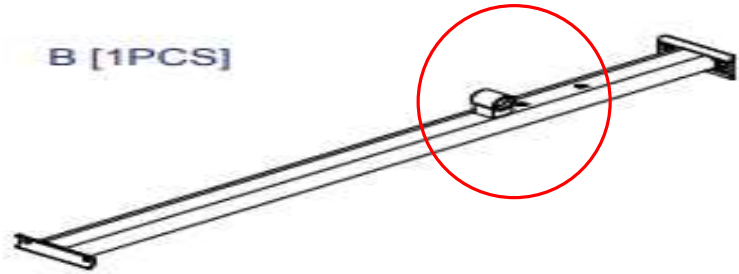

C [1PCS]

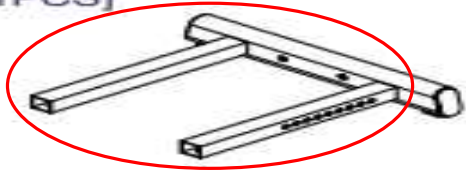

D [1PCS]



E [1PCS]

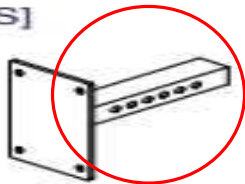

F [1PCS]

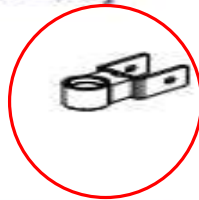

L [1PCS]

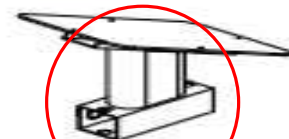

G [1PCS]

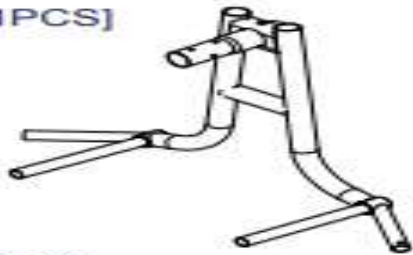

M [1PCS]

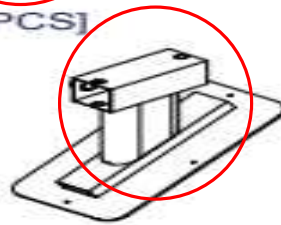

N [1PCS]

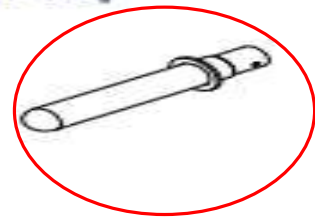

Q [1PCS]
9111086



R [2PCS]
8360-184(Pre-installed)

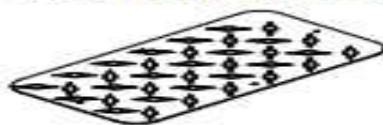

P [1PCS]

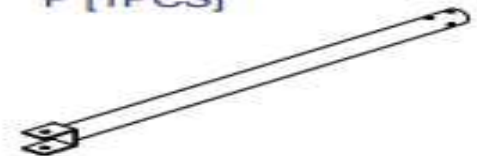

PLTR.5 PARTS

D1. Chrome collar (8130-254) (Pre-installed)-----	[4PCS]
D2. Flat head pop pin (8250-012) (Pre-installed)-----	[2PCS]
D3. Flat head pop pin (8250-065G) (Pre-installed)-----	[1PCS]
D4. Bearing (8510-003) (Pre-installed)-----	[4PCS]
D5. Chrome collar (8890-061) (Pre-installed)-----	[4PCS]
D6. Impregnated with handle (9162-147) (Pre-installed)-----	[2PCS]
D8. Impregnated with handle (9162-133) (Pre-installed)-----	[2PCS]
D9. End cap (9211-004)-----	[3PCS]
D10. Nylon bushing (9211-032)-----	[4PCS]
D11. Nylon bushing (9211-047)-----	[1PCS]
D12. End cap (9211-009)(Pre-installed)-----	[4PCS]
D14. Rubber dount (9214-045)-----	[2PCS]
D15. Rubber stop (9310-016)-----	[1PCS]
D16. Rubber insert (9310-076)-----	[2PCS]
D17. Cap sheath (9212-026)-----	[4PCS]
D18. Copper sheath (8520-032) (Pre-installed)-----	[4PCS]
D19. Impregnated with handle (9162-134) (Pre-installed)-----	[1PCS]
D21. Block Rubber (9310-119) (pre-installed)-----	[2PCS]
D22. Pinch Cock (OC06)-----	[1PCS]

D1



D2



D3



D4



D5



D6



D8



D9



D10



D11



D12



D14



D15



D16



D17



D18



D19







D21

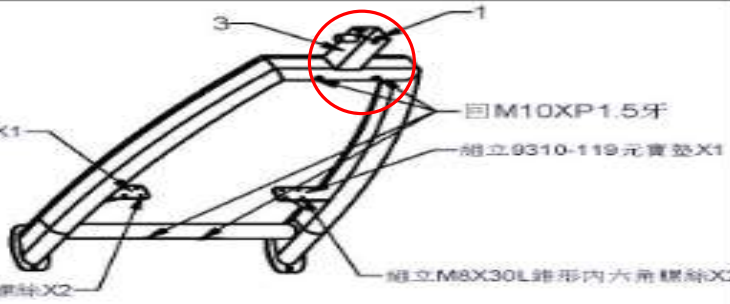
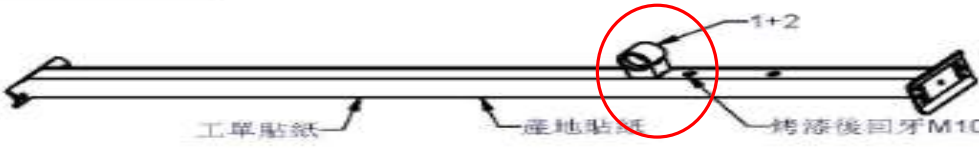
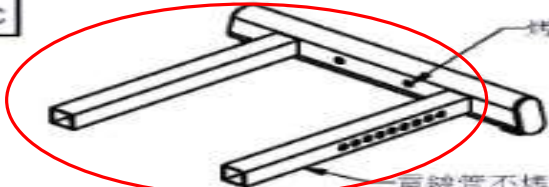

D22

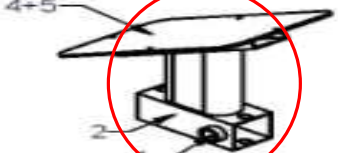
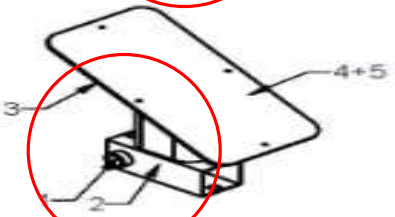

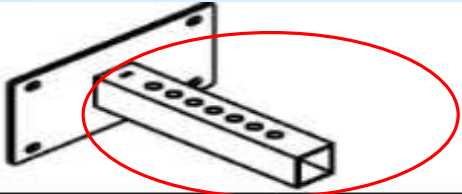
20PLTR.5-A	 <p>組立9310-119元實墊X1</p> <p>組立9310-119元實墊X1</p> <p>組立M8X30L錐形內六角螺絲X2</p> <p>組立M8X30L錐形內六角螺絲X2</p> <p>同M10XP1.5牙</p>	1PCS	<p>1.組立M10X25半圓頭內六角螺絲+M10螺帽各1PCS</p> <p>2.組立8250-065G調整組=1PCS</p> <p>3.貼9440-104注意貼紙=1PCS</p> <p>4.組立M8X30L錐形內六角螺絲=4PCS</p> <p>5.組立9310-119元實墊=2PCS</p> <p>整機二塗二烤 (除特殊標示)</p>
20PLTR.5-B	 <p>工單貼紙</p> <p>產地貼紙</p> <p>烤漆後同牙M10XP1.5牙 X2</p>	1PCS	<p>1.組立8510-003軸承=2PCS</p> <p>2.組立8520-032鐵套=2PCS</p>
20PLTR.5-C	 <p>烤漆後同牙M10XP1.5牙 X2</p> <p>扁鐵管不烤漆</p>	1PCS	
20PLTR.5-F	 <p>1+2</p>	1PCS	<p>1.組立8510-003軸承=2PCS</p> <p>2.組立8520-032鐵套=2PCS</p>
20PLTR.5-L	 <p>4+5</p> <p>2</p>	1PCS	<p>1.組立8250-012調整組=1PCS</p> <p>2.貼9440-104=1PCS</p> <p>3.組立9211-009方塞=2PCS</p> <p>4.組立8360-184鋁花紋板=1PCS</p> <p>5.組立M4X10L開口鉚釘=4PCS (注意,一定先組立方塞再拉鉚釘)</p>
20PLTR.5-M	 <p>4+5</p> <p>3</p> <p>2</p>	1PCS	<p>1.組立8250-012調整組=1PCS</p> <p>2.貼9440-104=1PCS</p> <p>3.組立9211-009方塞=2PCS</p> <p>4.組立8360-184鋁花紋板=1PCS</p> <p>5.組立M4X10L開口鉚釘=4PCS (注意,一定先組立方塞再拉鉚釘)</p>

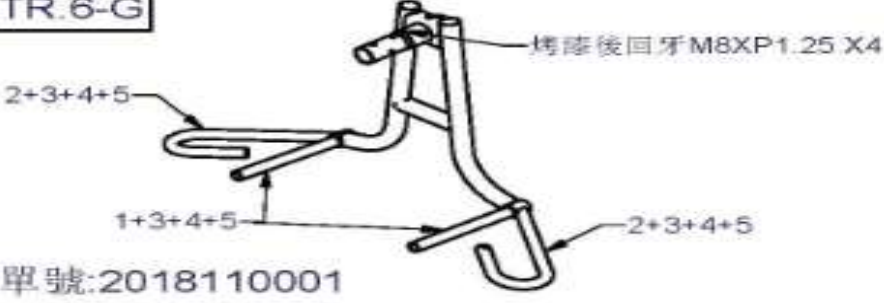
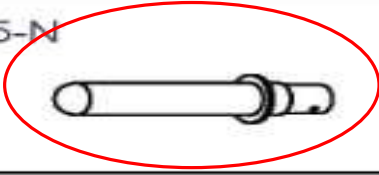
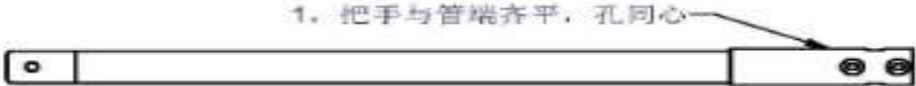
20PLTR.6-E		1PCS		
20PLTR.5-D		1PCS	1.貼9440-216=1PCS LOGO貼紙 注意方向	
20PLTR.6-G	 <p>2+3+4+5</p> <p>1+3+4+5</p> <p>2+3+4+5</p> <p>烤漆後回牙M8XP1.25 X4</p> <p>設變單號:2018110001</p>	1PCS	1.組立9162-147浸漬把手 ($\varnothing 24 \times 5 \text{TX} 210$)=2PCS 2.組立9162-226浸漬把手 ($\varnothing 24 \times 5 \text{TX} 450$)=2PCS 3.組立8130-254固定束子=4PCS 4.組立8890-061固定束子=4PCS 5.組立M5X5沉頭內六角螺絲 =16PCS 組裝噴把手需先用砂紙打毛 鐵管,再用膠水粘牢。	
20PLTR.5-N	26PLTR.5-N		1PCS	
22PLTR.6-P	 <p>1. 把手与管端齐平, 孔同心</p>	1PCS	1.組立浸漬把手 9162-134=1PCS ($\varnothing 57 \times 3 \text{TX} 200$)	
電鍍				

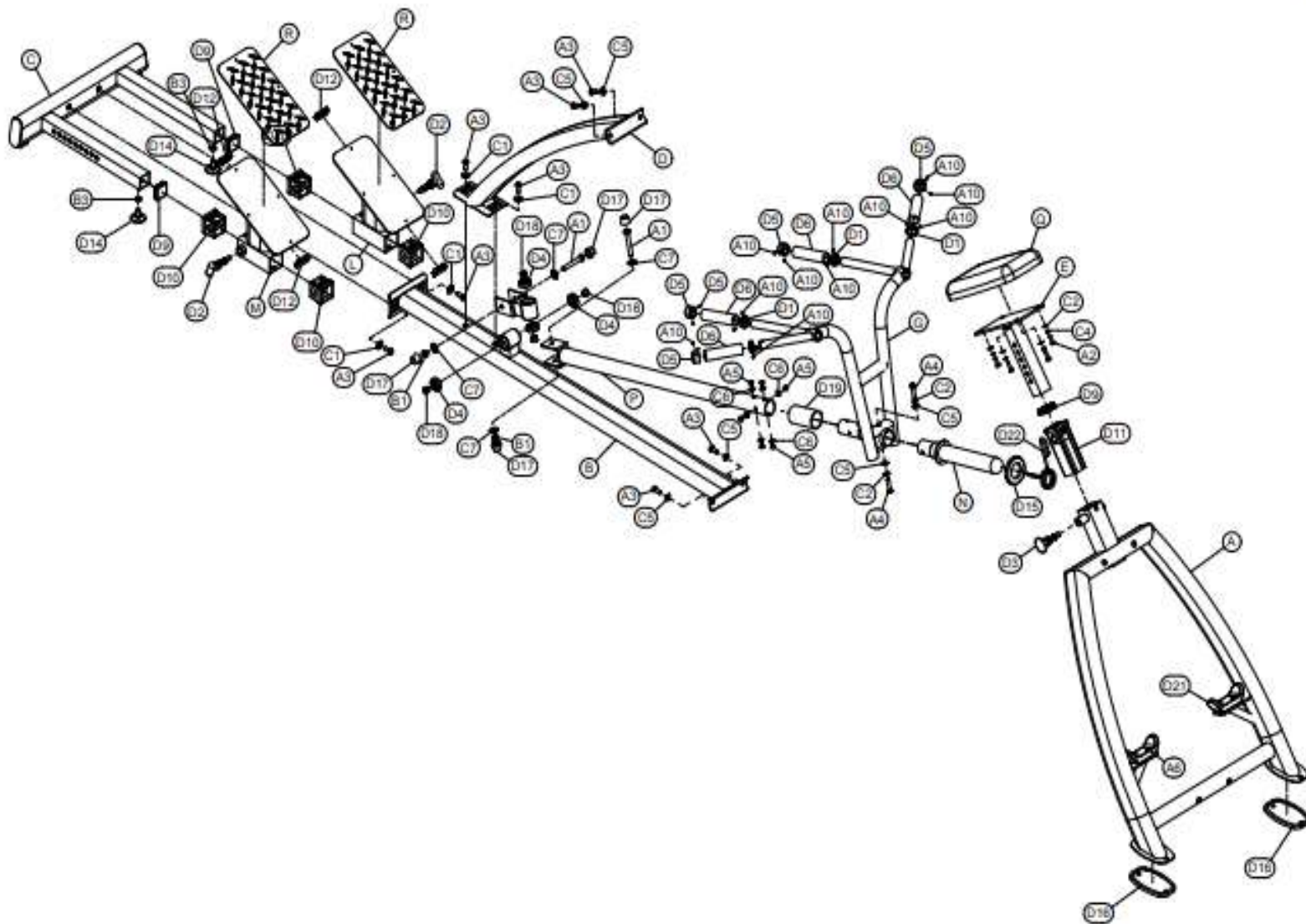

*Well done!

