

* MCP2200 Maintenance



* Customers can put some grease on pivot points (red circle place), with brass or gunmetal bushings.



WD-40多种规格



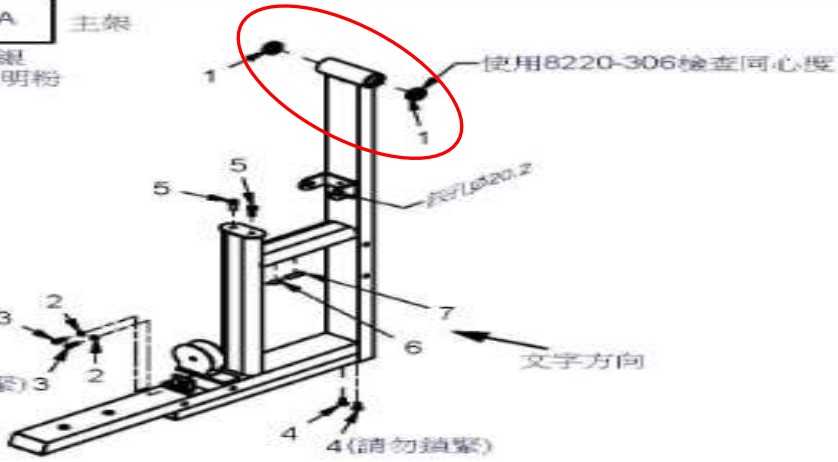
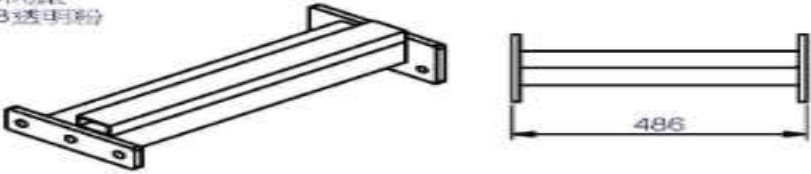
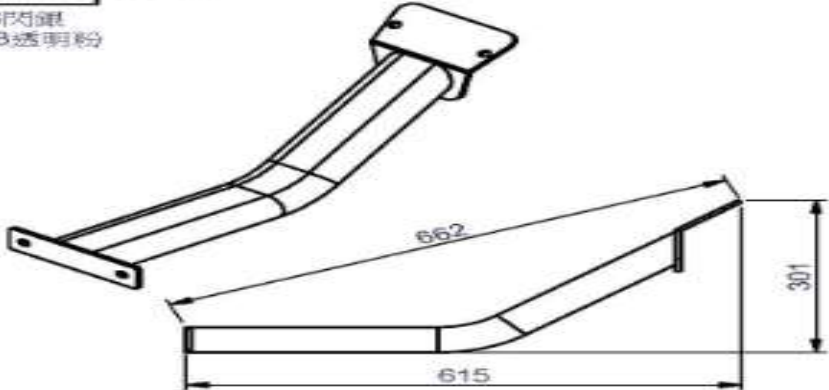

* Let's maintain your machine!

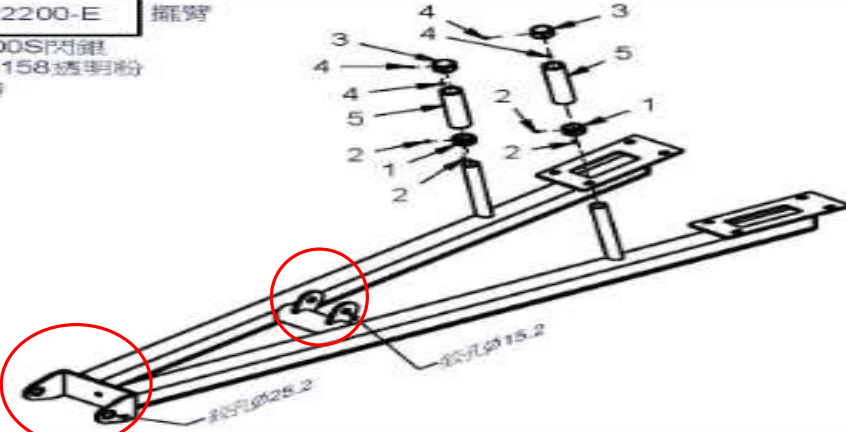
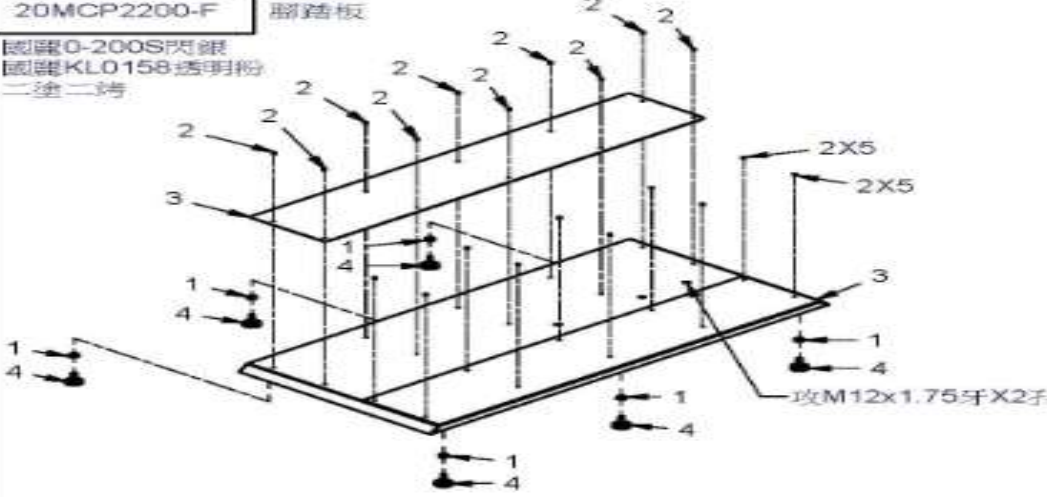
| 零件代碼 | 品名及圖案 | 用量 | 備註 |
|--|--|------|--|
| 20MCP2200-A 國標0-200S閃銀 國標KL0158透明粉 二塗二烤 | 主架  | 1SET | 1.組立8510-018軸承=2PCS 2.組立M10彈簧華司=2PCS 3.組立M10X25L 半圓頭內六角螺絲=2PCS 4.組立M10X25L 錐形平頭內六角螺絲=2PCS 5.組立M12X30L 圓頭內六角螺絲CAP=2PCS 6.貼9440-055貼紙=1PCS 7.貼"工單貼紙"貼紙=1PCS |
| 20MCP2200-B 國標0-200S閃銀 國標KL0158透明粉 二塗二烤 | 連接管  | 1SET | |
| 20MCP2200-C 國標0-200S閃銀 國標KL0158透明粉 二塗二烤 | 連接管  | 1SET | |

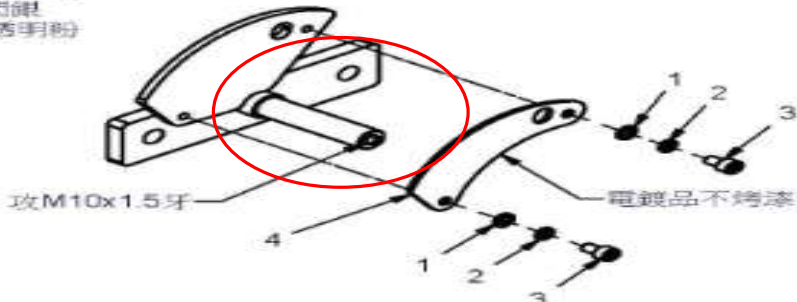
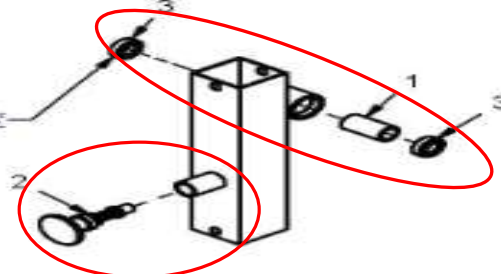
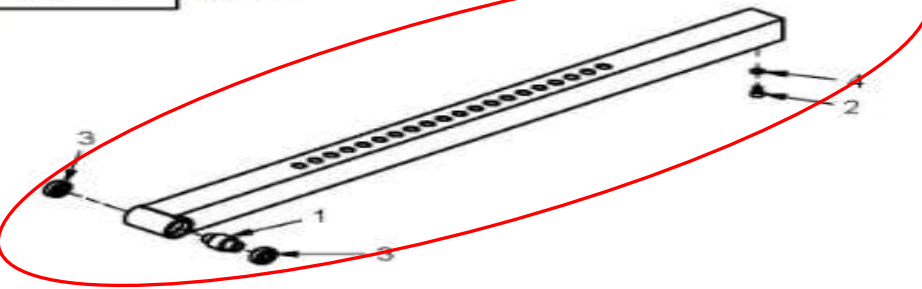

| 零件代碼 | 品名及圖案 | 用量 | 備註 |
|--|--|------|---|
| 20MCP2200-D 國麗0-200S閃銀 國麗KL0158透明粉 二塗二烤 | 擺動架  <p>使用B220-305檢查同心度</p> | 1SET | 1.組立8510-034軸承=2PCS |
| 20MCP2200-E 國麗0-200S閃銀 國麗KL0158透明粉 二塗二烤 | 擺臂  <p>螺孔φ15.2</p> | 1SET | 1.組立8130-250束子=2PCS 2.組立3/16"X3/16"L 沈頭內六角螺絲=4PCS 3.組立8890-079鐵套=2PCS 4.組立M5X4L 沈頭內六角螺絲=4PCS 5.組立9162-111 高密度把手=2PCS |
| 20MCP2200-F 國麗0-200S閃銀 國麗KL0158透明粉 二塗二烤 | 腳踏板  <p>攻M12x1.75牙X2孔</p> | 1SET | 1.組立3/8"螺帽=6PCS 2.組立435(4-3)拉釘=20PCS 3.組立8370-057基板=2PCS 4.組立9214-011緩衝墊=6PCS |

設變車號
201810007

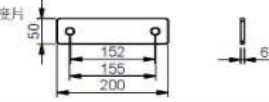
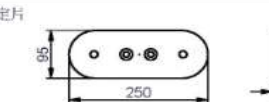
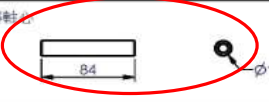
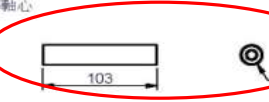
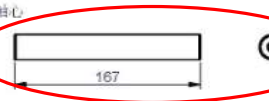

| 零件代碼 | 品名及圖案 | 用量 | 備註 |
|---|-------|------|---|
| 20MCP2200-G 國麗0-200S閃銀 國麗KLO158透明粉 二塗二烤 不可以烤漆 電線管 305 攻M6x1牙 | | 1SET | 1.組立435(4-3)拉釘=4PCS 2.組立8370-063壓花板=2PCS 3.組立M6X25L 圓頭內六角螺絲CAP=2PCS 4.組立8910-052 (U型把手)=1PCS 5.組立9214-051避震墊=3PCS 6.組立M10X20L 半圓頭內六角螺絲=3PCS |
| 20MCP2200-L 國麗0-200S閃銀 國麗KLO158透明粉 二塗二烤 用 $\varnothing 20$ 心軸檢查同心度 | | 1SET | 1.組立8250-002調整組=1PCS 2.組立8250-007調整組=1PCS 3.組立8510-010軸承=2PCS |
| 總組立 | | 1SET | 1.組立9211-033雙層套=1PCS 2.組立9211-036按扣墊=4PCS 3.組立M6X15L 圓頭內六角螺絲CAP=1PCS 4.組立M6彈簧華司=1PCS |

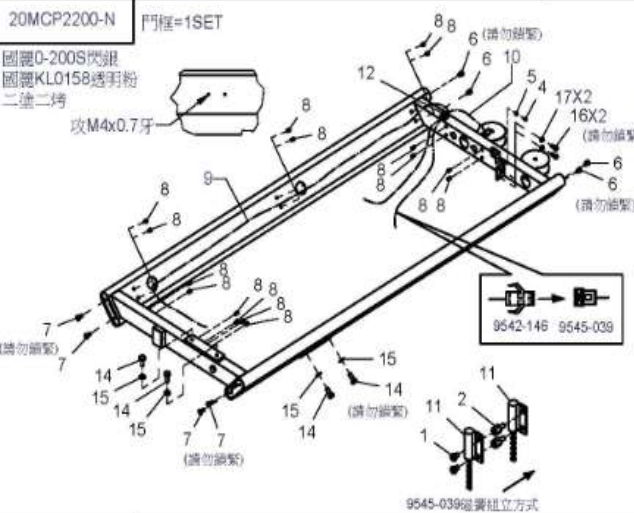
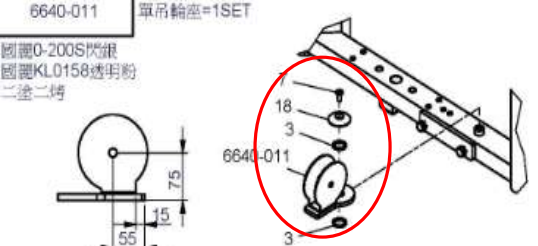
| 零件代碼 | 品名及圖案 | 用量 | 備註 |
|--|---|------|--|
| 20MCP2200-H 國麗0-200S閃銀 國麗KLO158透明粉 二塗二烤 | 調整組立桿接件  | 1SET | 1.組立M8華司 $\varnothing 14 \times 2T=2PCS$ 2.組立M8彈簧華司=2PCS 3.組立M8X12L 圓頭內六角螺絲CAP=2PCS 4.組立8343380-26 固定片=1PCS |
| 20MCP2200-I 國麗0-200S閃銀 國麗KLO158透明粉 二塗二烤 | 滑座 使用8210-197檢查同心度  | 1SET | 1.組立8120-111鐵套=1PCS 2.組立8250-066調整組=1PCS 3.組立8510-011軸承=2PCS |
| 26MCP2200J 電鍍 | 調整管  | 1SET | 1.組立20HCP2200-J 轉軸心=1PCS 2.組立5/16"X1/2"L 圓頭內六角螺絲CAP=1PCS 3.組立8510-063軸承=2PCS 4.組立5/16"彈簧華司=1PCS 委外加工 取20MCP2200-J |
| 20HCP2200-J 國麗0-200S閃銀 | 轉軸心  | 1SET | |

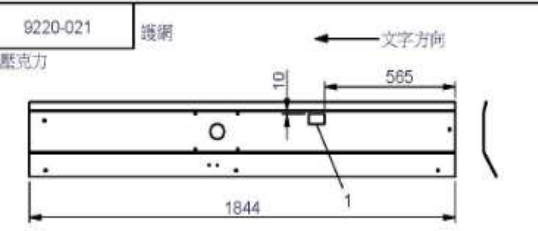
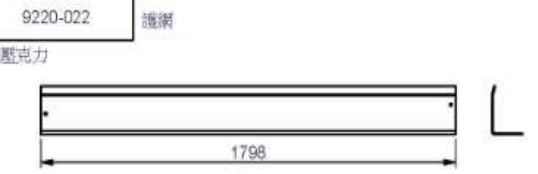
| 零件代碼 | 品名及圖案 | 用量 | 備註 |
|------------|--|------|--------------|
| 8311-117 | 固定片  | 1PCS | HLMCP2200A內箱 |
| 8312-077 | 連接片  | 1PCS | HLMCP2200A內箱 |
| 8313-188 | 固定片  | 1PCS | HLMCP2200A內箱 |
| 8210-197 | 轉軸心  | 1PCS | HLMCP2200A內箱 |
| 8220-305 | 轉軸心  | 1PCS | HLMCP2200A內箱 |
| 8220-306 | 轉軸心  | 1PCS | HLMCP2200A內箱 |
| 23MCP2200A | 附件包 | | HLMCP2200A內箱 |
| 25MCP2200A | 皮帶輪包 | | HLMCP2200A內箱 |
| 9420-146 | 動作蓋銘板 | | 9630-126氣泡袋 |
| GMCP2200A | 螺絲包 | | HLMCP2200A內箱 |
| KMCP2200 | 說明書 | | |
| 零件代碼 | 品名及圖案 | 用量 | 備註 |
| FMCP2200A | 3680mm平面皮帶 | 1PCS | |
| FMCP2200B | 2540mm平面皮帶 | 1PCS | |

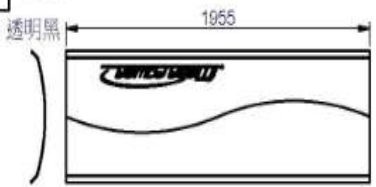
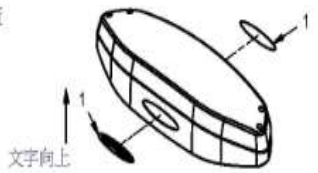
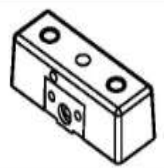
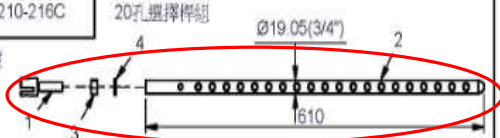
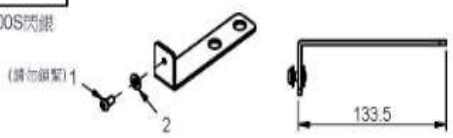
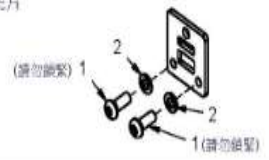
| 零件代碼 | 品名及圖案 | 用量 | 備註 |
|-------------|---|------|--|
| 20MCP2200-N | 門框=1SET  | | 1.組立M3X6L 半圓頭十字螺絲=2PCS 2.組立9215-021 螺絲螺柱=2PCS 3.組立8520-008封草可=2PCS 4.組立M6X12L 半圓頭內六角螺絲=1PCS 5.組立M6螺絲可Ø13=1PCS 6.組立M10X12L 圓頭內六角螺絲CAP=4PCS 7.組立M10X25L 圓頭內六角螺絲=5PCS 8.組立M6拉帽 （身體有7）=16PCS 9.組立9542-145 扣鎖線（下段）=1PCS 10.組立9542-146 扣鎖線=1PCS 11.鎖鈕19545-039 磁簧感應螺絲=1PCS 12.組立9260-023 配鎖固定座=1PCS 13.組立9630-163 YS-8卷式給索帶=1PCS 14.組立1/2"X1-1/4"L 一般外六角螺絲=4PCS 15.組立1/2"螺絲可Ø25=4PCS 16.組立M10X25L 半圓頭內六角螺絲=2PCS 17.組立M10螺絲母可=2PCS 18.組立8130-231端蓋=1PCS |
| 6640-011 | 單吊輪座=1SET  | | 配合處軸心不可烤漆  |
| 9220-021 | 護網  | 1PCS | 1.貼9440-117防夾手貼紙=1PCS |
| 9220-022 | 護網  | 1PCS | |

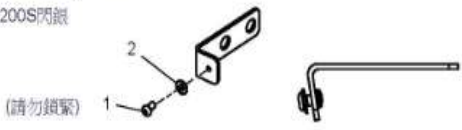
| 零件代碼 | 品名及圖案 | 用量 | 備註 |
|------------|---|------|--|
| 9220-024 | 護網 | | |
| 壓克力護網 | 透明黑  | 1PCS | |
| 9211-148 | 上蓋 | | |
| |  文字向上 | 1PCS | 1.貼9441-370=2PCS 鋁標(Steelflex) |
| | | | H9211148 |
| 8400-033 | 選擇上片 | | |
| 黑色烤漆 |  | 1PCS | HLMCP2200B |
| 8210-216C | 20孔選擇桿組 | | |
| 電鍍 |  | 1SET | 1.組立8280-076固定桿=1PCS 2.組立8210-216 20孔選擇桿=1PCS 3.組立1/2"螺帽=1PCS 4.組立1/2"彈簧華司=1PCS |
| 8331-057 | L型片 | | |
| 國麗0-200S閃銀 |  | 4SET | 1.組立M6X12L 半圓頭內六角螺絲=4PCS 2.組立M6華司Ø13=4PCS |
| | | | HLMCP2200B |
| 8313-169 | 固定片 | | |
| 電鍍 |  | 1PCS | 1.組立M10X25L 半圓頭內六角螺絲=2PCS 2.組立M10彈簧華司=2PCS |
| | | | HLMCP2200B |

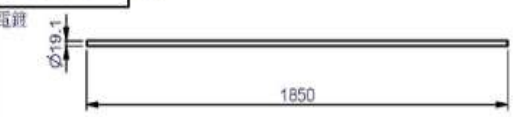
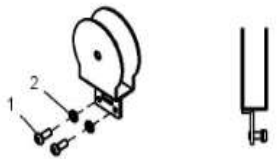
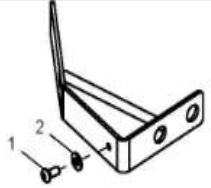
| 零件代碼 | 品名及圖案 | 用量 | 備註 |
|-----------------------------------|--|------|--|
| 8331-058 | L型片 | | |
| 國麗0-200S閃銀 |  | 2SET | 1.組立M6X12L 半圓頭內六角螺絲=2PCS 2.組立M6華司-Ø13=2PCS |
| | | | HLMCP2200B |
| 8313-144 | 固定片 | | |
| 國麗0-200S閃銀 國麗KL0158透明粉 二塗二烤 |  | 2PCS | HLMCP2200B |
| 8280-043 | 導桿 | | |
| 電鍍 |  | 2PCS | |
| 6640-009 | 單吊輪座 | | |
| 國麗0-200S閃銀 國麗KL0158透明粉 二塗二烤 |  | 1SET | 1.組立M10X25L 半圓頭內六角螺絲=2PCS 2.組立M10彈簧華司=2PCS |
| | | | HLMCP2200B |
| 6640-022 | 固定架 | | |
| 國麗0-200S閃銀 |  | 1SET | 1.組立M6X12L 半圓頭內六角螺絲=1PCS 2.組立M6華司-Ø13=1PCS |
| | | | HLMCP2200B |
| 23MCP2200B | 附件包 | 1SET | HLMCP2200B |
| 23MDCUP | 附件包-CUP | 1SET | HLMCP2200B |
| 25MCP2200B | 皮帶輪包 | 1SET | HLMCP2200B |
| GMCP2200B | 螺絲包 | 1SET | HLMCP2200B |
| KMD | 操作手冊 | 1SET | HLMCP2200B |

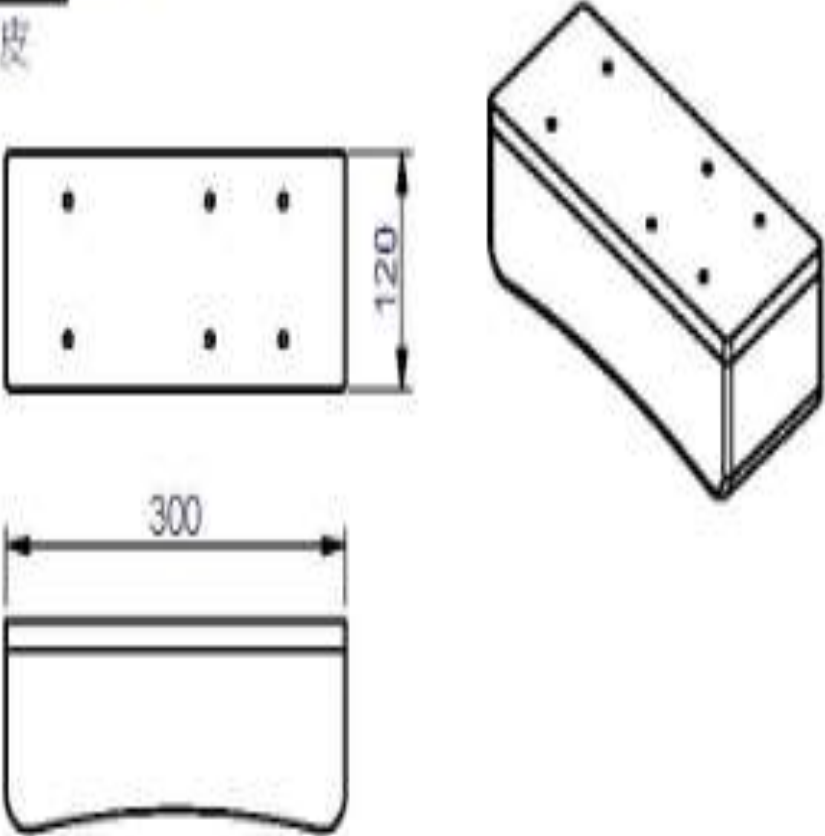
| 零件代碼 | 品名及圖案 | 用量 | 備註 |
|----------|--|------|----|
| 9131-064 | <p data-bbox="388 277 459 329">同墊</p> <p data-bbox="112 379 343 432">黑色耐寒乳膠皮</p>  <p>The technical drawing shows a rectangular pad with a width of 120 and a length of 300. The top surface features six circular holes arranged in two rows of three. A 3D perspective view shows the pad's thickness and the arrangement of the holes on the top surface.</p> | 2PCS | |

MCP-2200 ASSEMBLY INSTRUCTIONS

HARDWARE ILLUSTRATION

| | |
|------------------------------------|---------------|
| D1. Ø50 CAP COVER(8130-131) | [5PCS] |
| D2. 60x50 NYLON BUSHING(9211-033) | [2PCS] |
| D3. 2"x2" End Cap (9211-005) | [1PCS] |
| D4. Rubber Stopper (9310-057) | [1PCS] |
| D5. 108X263 RUBBER PAD(9310-075) | [1PCS] |
| D6. Ø115 PULLEY(9213-042B) | [2PCS] |
| D7. 3680mm BELT(FMCP2200A) | [1PCS] |
| D8. 2570mm BELT(FMCP2200B1) | [1PCS] |
| D9. EXERCISE CHART (9420-146) | [1PCS] |
| D21. Ø1" CU WASHER(8520-008) | [2PCS] |

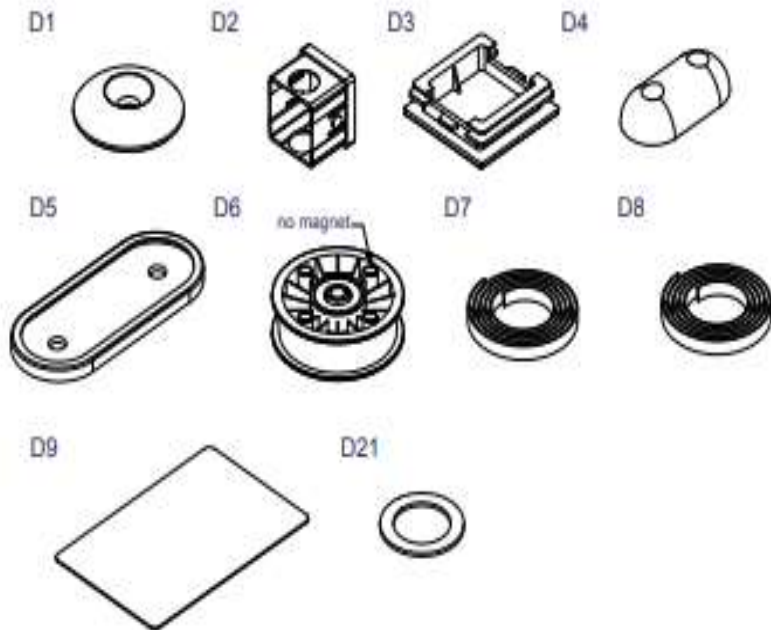

MCP-2200 ASSEMBLY INSTRUCTIONS

DOOR FRAME HARDWARE ILLUSTRATION

| | |
|-----------------------------------|---------------|
| D10. 3/4" SHAFT COLLAR(9211-147) | [2PCS] |
| D11. 3/4" SHAFT COLLAR(9211-167) | [2PCS] |
| D12. Ø4" RUBBER PAD(9310-017) | [2PCS] |
| D13. 108X263 RUBBER PAD(9310-075) | [2PCS] |
| D15. Ø115 PULLEY(9213-042B) | [4PCS] |
| D16. BOTTLE BRACKET(8388-025) | [1PCS] |
| D17. BOTTLE RACK(9260-320) | [1PCS] |
| D18. BOTTLE(9260-123) | [1PCS] |

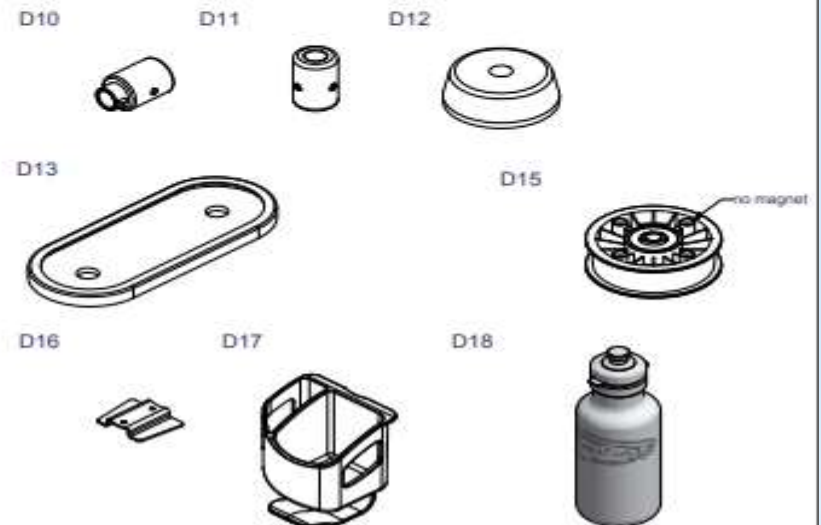

MCP-2200 ASSEMBLY INSTRUCTIONS

DOOR FRAME HARDWARE ILLUSTRATION

| | |
|------------------------------|--------|
| D19. TOP PLATE(8400-033) | [1PCS] |
| D20. Selector Rod(8210-216C) | [1PCS] |



MCP-2200 ASSEMBLY INSTRUCTIONS

PARTS ILLUSTRATION SHEET

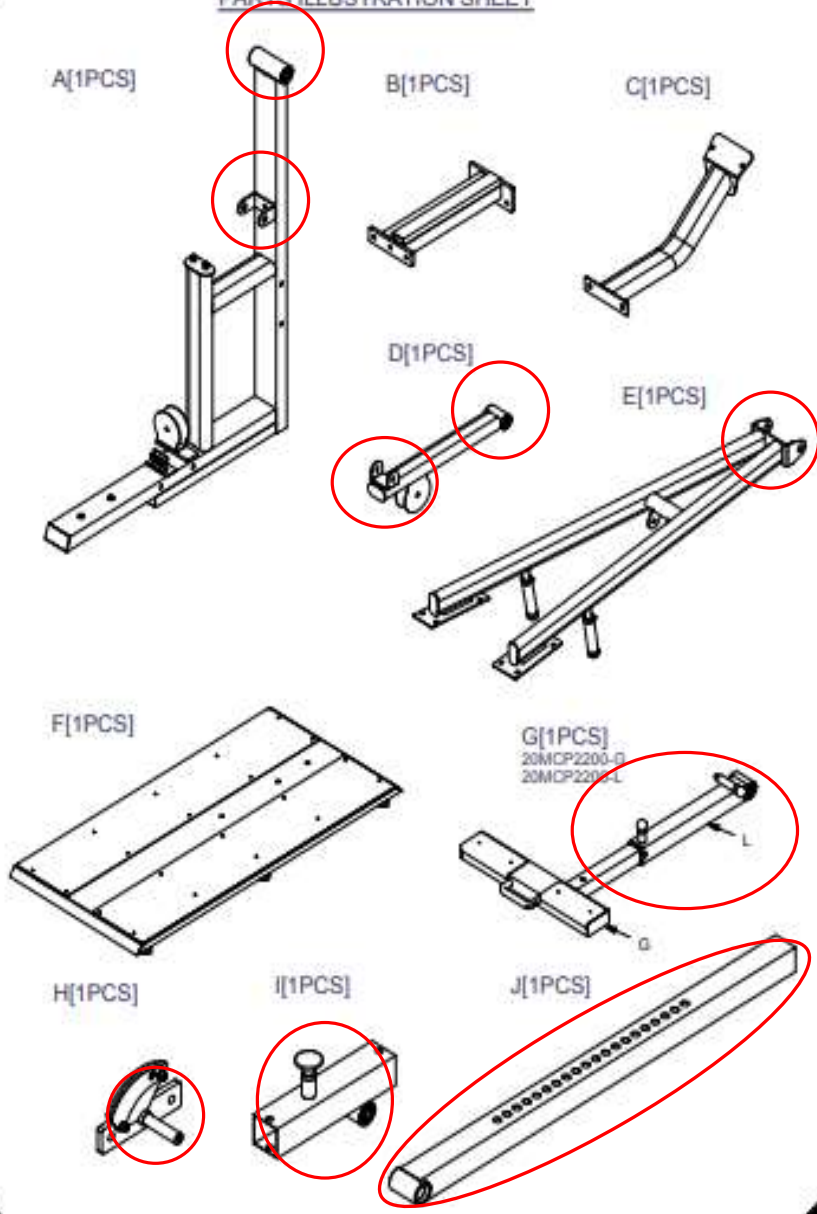

MCP-2200 ASSEMBLY INSTRUCTIONS

PARTS ILLUSTRATION SHEET

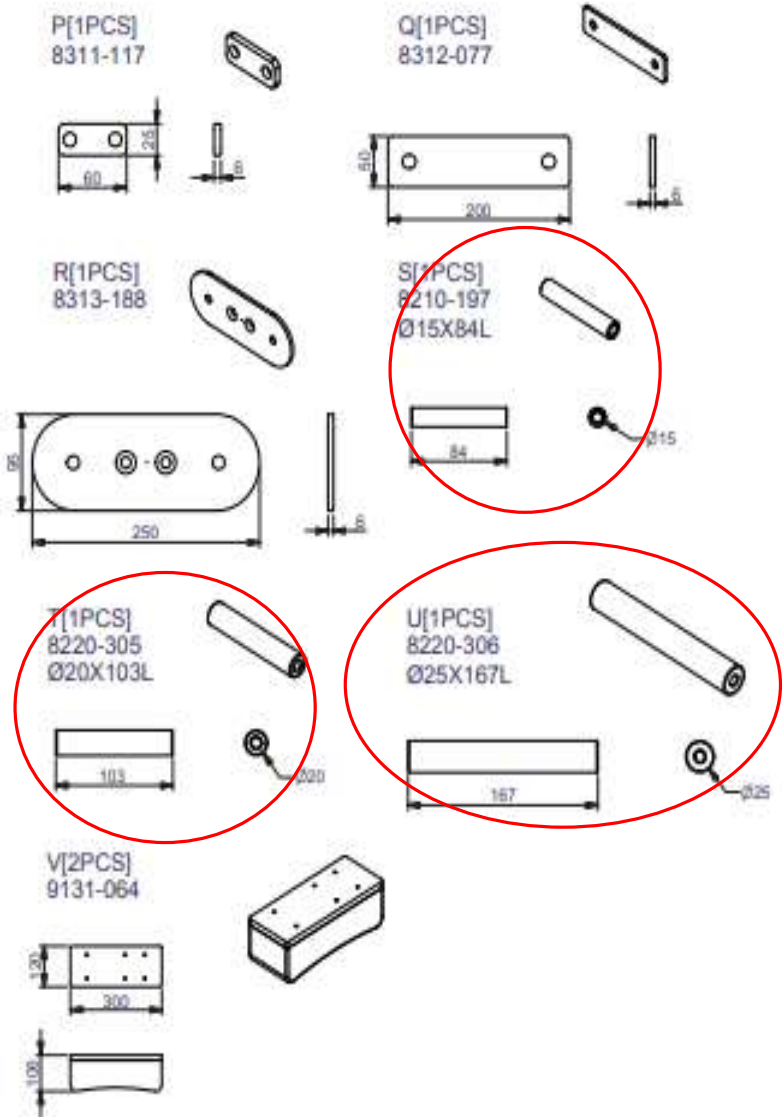

MCP-2200 ASSEMBLY INSTRUCTIONS

DOOR FRAME PARTS ILLUSTRATION SHEET

AA1[1PCS]

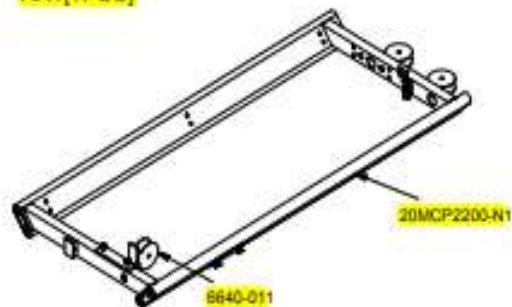

AC1[1PCS]
9220-053



AD[1PCS]
9220-022



AE[1PCS]
9220-024

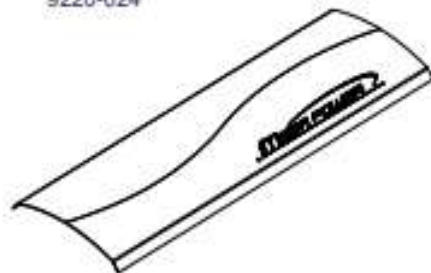

AF[1PCS]
9211-148



MCP-2200 ASSEMBLY INSTRUCTIONS

DOOR FRAME PARTS ILLUSTRATION SHEET

AG[1PCS]
6640-009

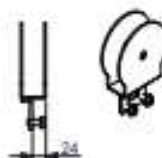

AH[4PCS]
8331-057

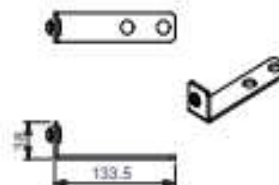

AI[1PCS]
8313-169

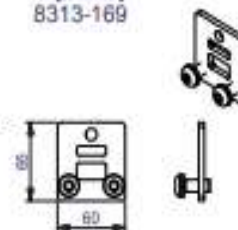

AJ[2PCS]
8331-058

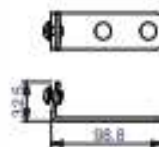

AK[2PCS]
8313-144

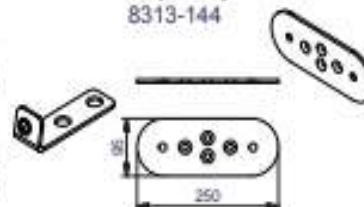

AL[2PCS]
8280-043
Ø3/4"X1850L



AM[1PCS]
8331-056

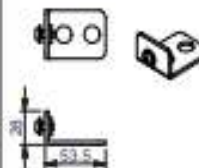

AP[3PCS]
8311-117

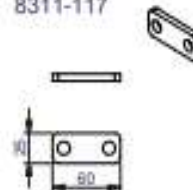

AR[1PCS]
6640-022



AS[1PCS]
8311-194

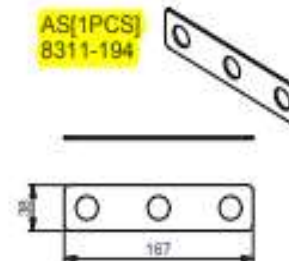

MCP-2200 ASSEMBLY INSTRUCTIONS



Above shows STEP 1 assembled and completed

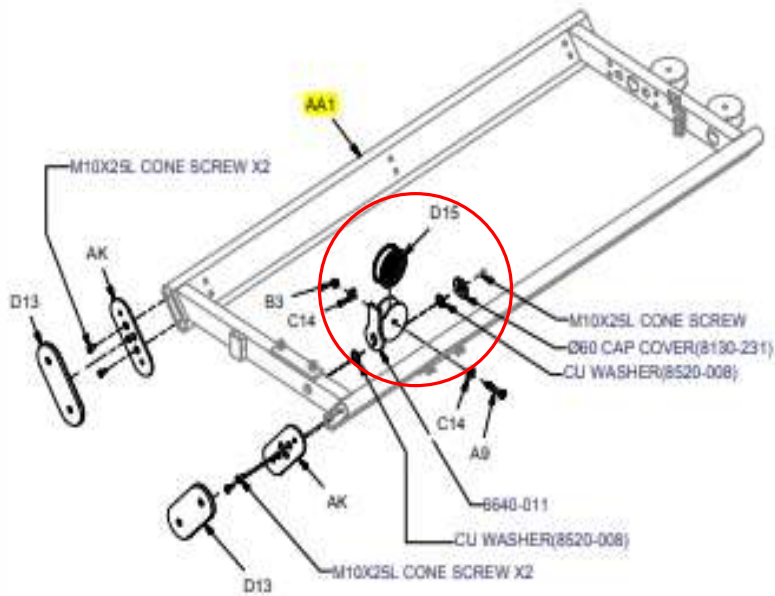

MCP-2200 ASSEMBLY INSTRUCTIONS

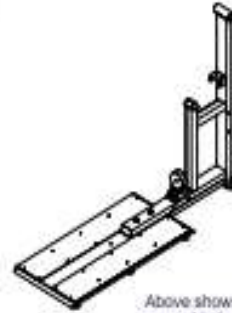

Above shows STEP 2 assembled and completed

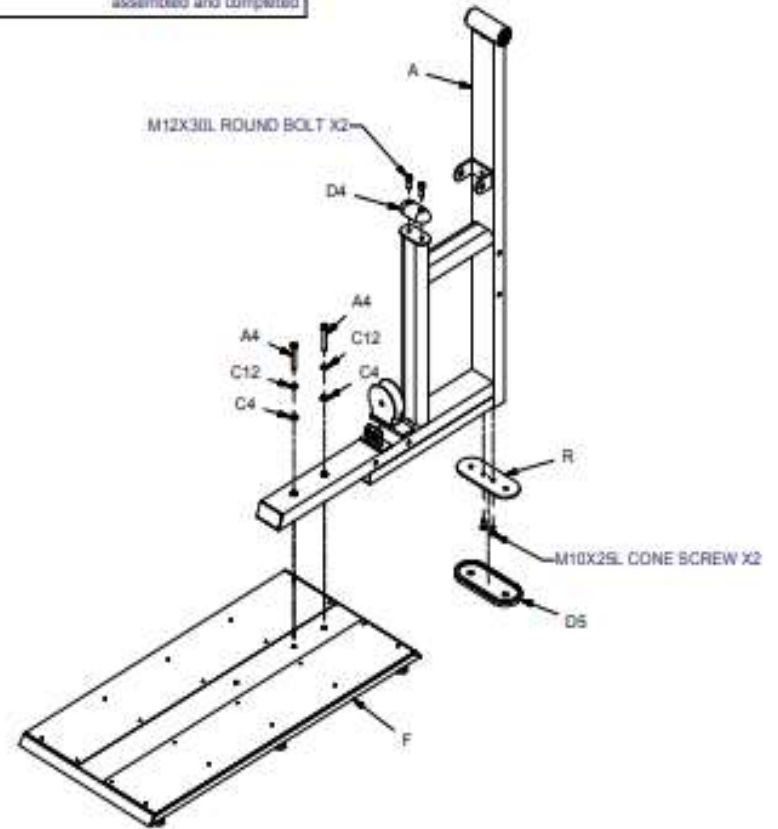

MCP-2200 ASSEMBLY INSTRUCTIONS



Above shows STEP 3 assembled and completed

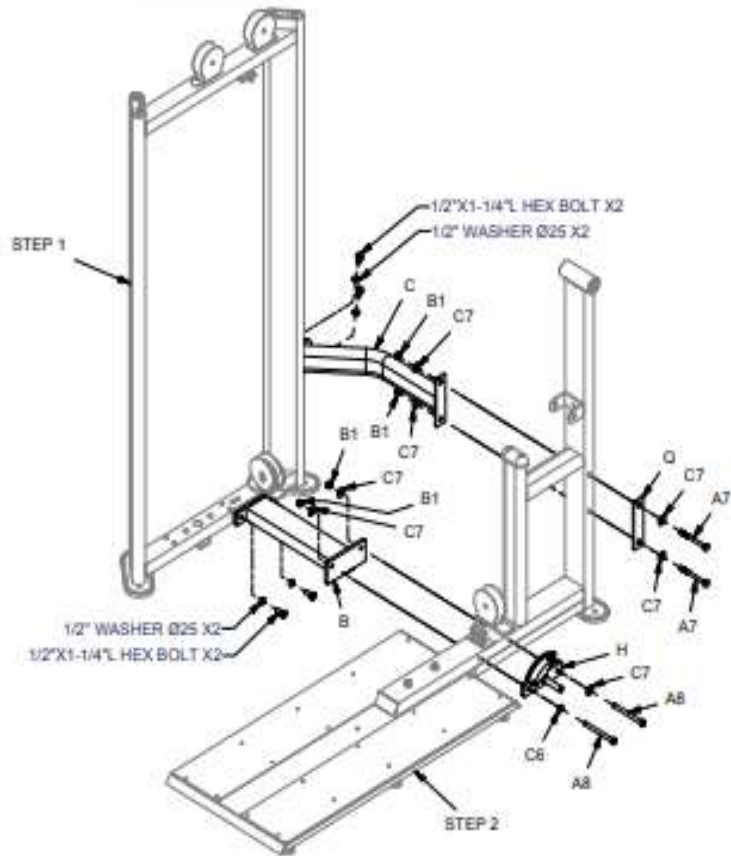

MCP-2200 ASSEMBLY INSTRUCTIONS

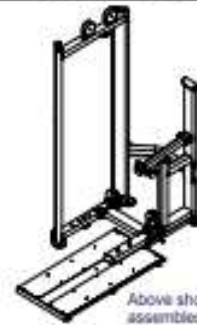

Above shows STEP 4 assembled and completed

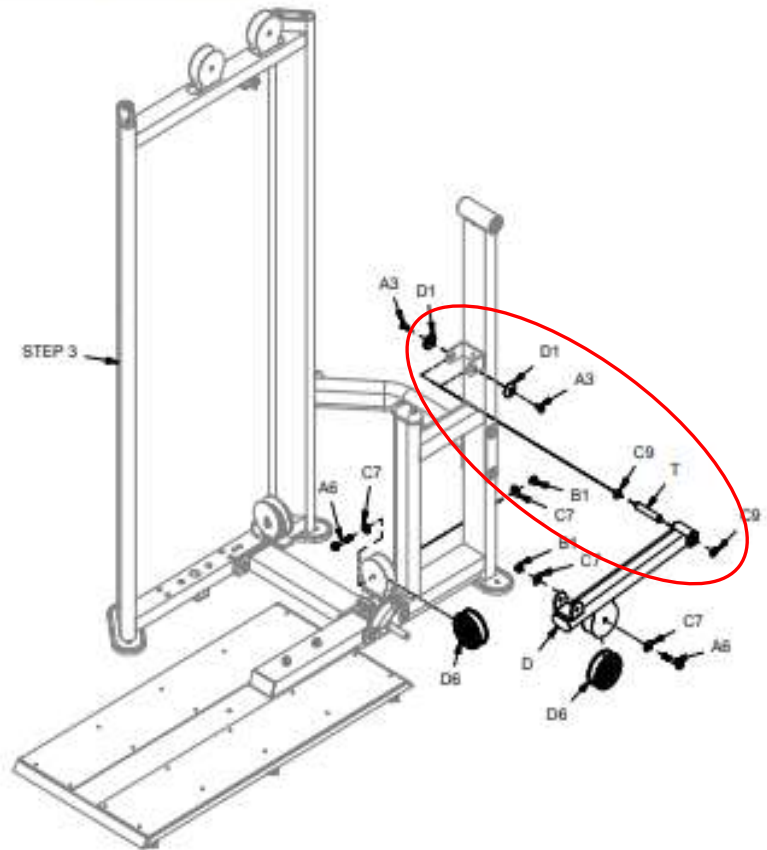

MCP-2200 ASSEMBLY INSTRUCTIONS

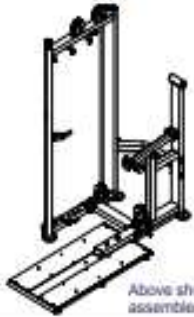

Above shows STEP 5 assembled and completed

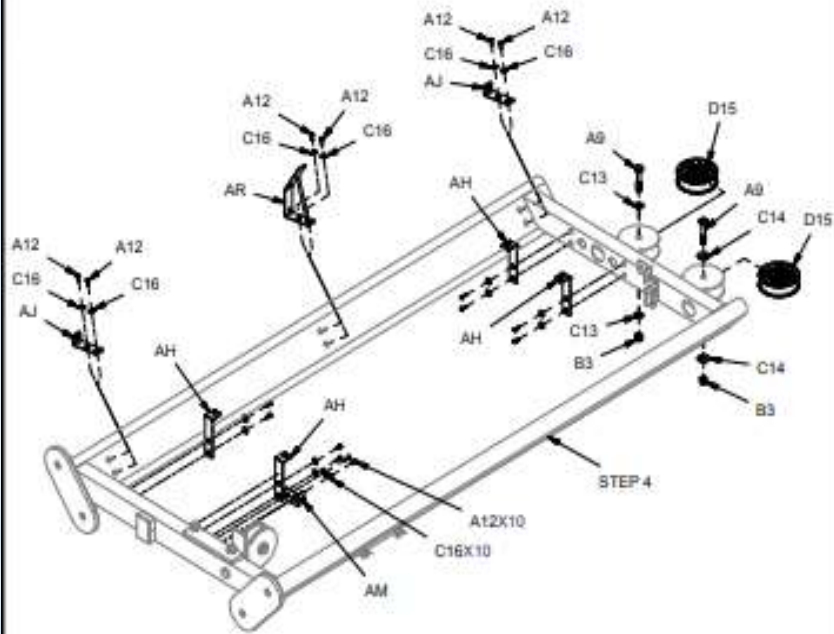

MCP-2200 ASSEMBLY INSTRUCTIONS

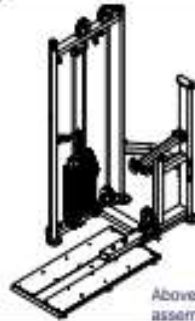

Above shows STEP 6 assembled and completed

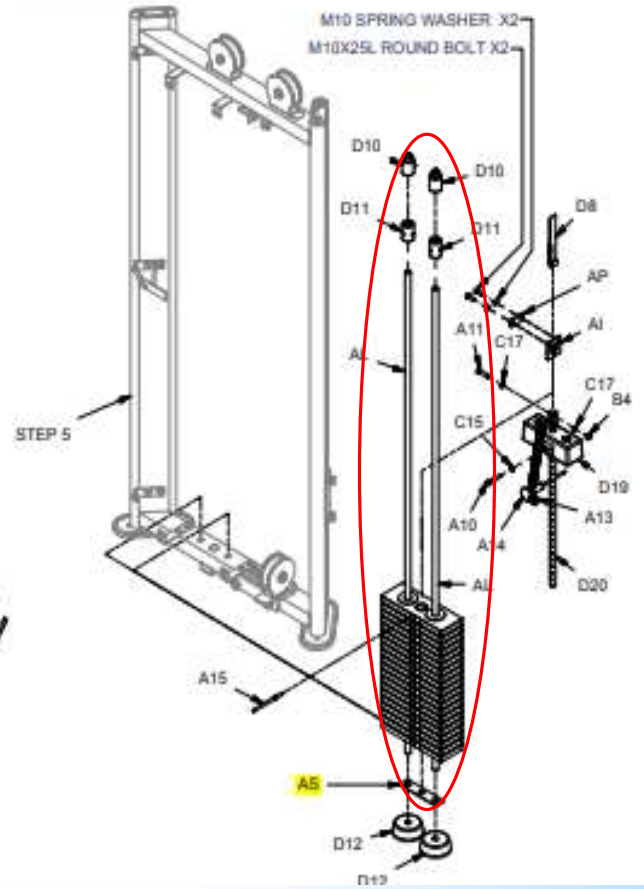

MCP-2200 ASSEMBLY INSTRUCTIONS

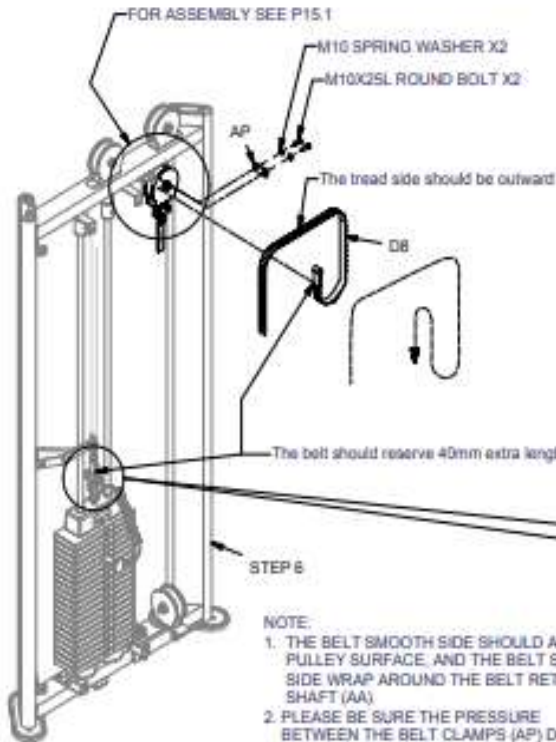

Figure 2

STEP 6

NOTE:

1. THE BELT SMOOTH SIDE SHOULD ATTACH ON PULLEY SURFACE, AND THE BELT SMOOTH SIDE WRAP AROUND THE BELT RETAINER SHAFT (AA).
2. PLEASE BE SURE THE PRESSURE BETWEEN THE BELT CLAMPS (AP) DO NOT EXCEED 70-PSI

Adjust Belt Procedure:

1. Lift the selector rod a little and then insert the pin between first weight stack and top plate (Do not insert through the first hole of the rod), and there are 7 mm gap between top plate and first weight stack.
2. Adjust the belt to have proper tension and then tighten the belt clamps.
3. Remove the pin and let the top plate fall on the first weight plate.

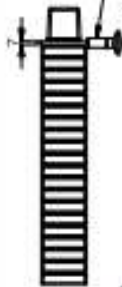
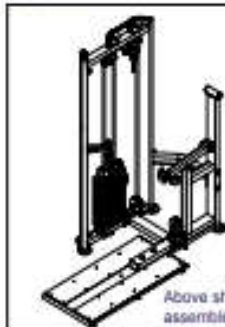

Figure 3



Above shows STEP 7 assembled and completed

MCP-2200 ASSEMBLY INSTRUCTIONS

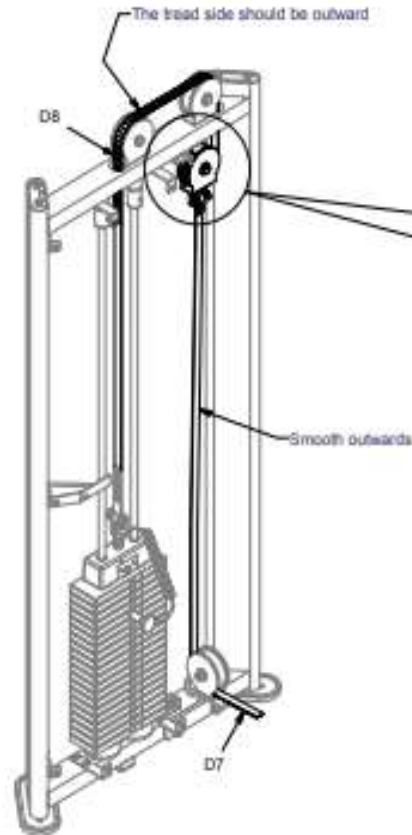

Figure 4

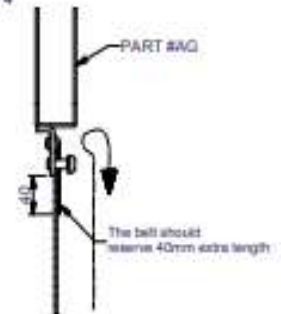
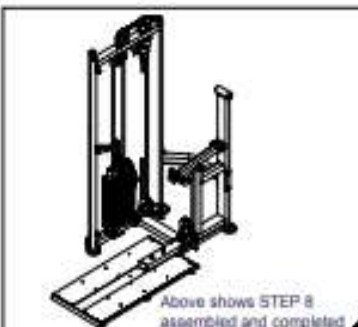
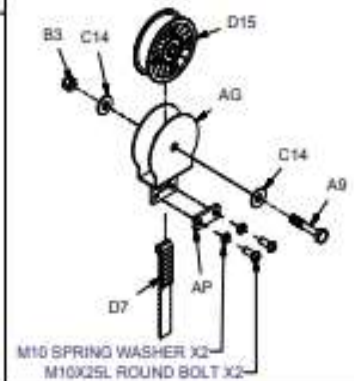

Figure 5



Above shows STEP 8 assembled and completed

MCP-2200 ASSEMBLY INSTRUCTIONS



Above shows STEP 9 assembled and completed

- NOTE
1. THE BELT SMOOTH SIDE SHOULD ATTACH ON PULLEY SURFACE, AND THE BELT SMOOTH SIDE WRAP AROUND THE BELT RETAINER SHAFT (A)
 2. PLEASE BE SURE THE PRESSURE BETWEEN THE BELT CLAMPS (F) DO NOT EXCEED 70 PSI

MCP-2200 ASSEMBLY INSTRUCTIONS



Above shows STEP 10 assembled and completed

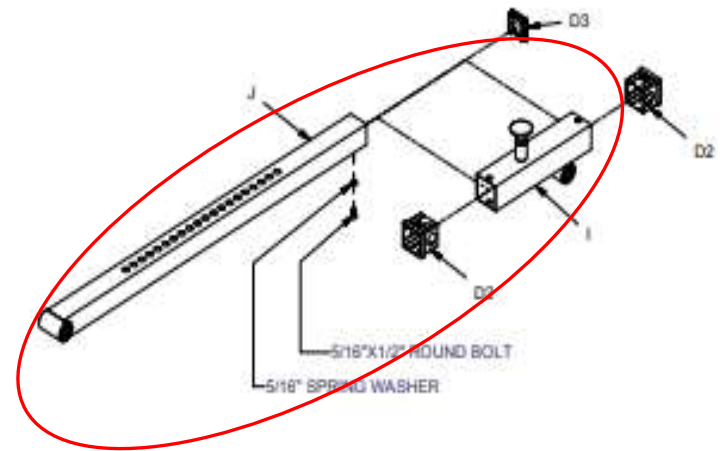
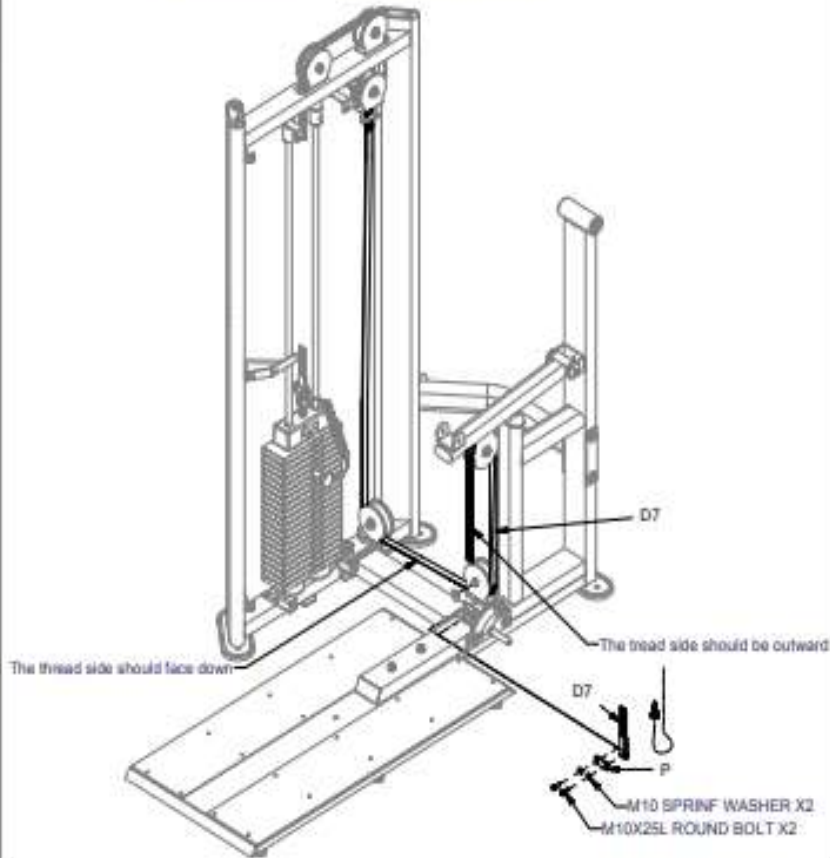

MCP-2200 ASSEMBLY INSTRUCTIONS



Above shows STEP 11 assembled and completed

Figure 6

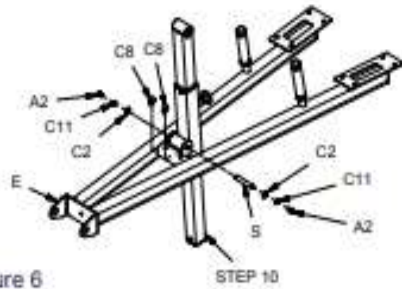

STEP 10

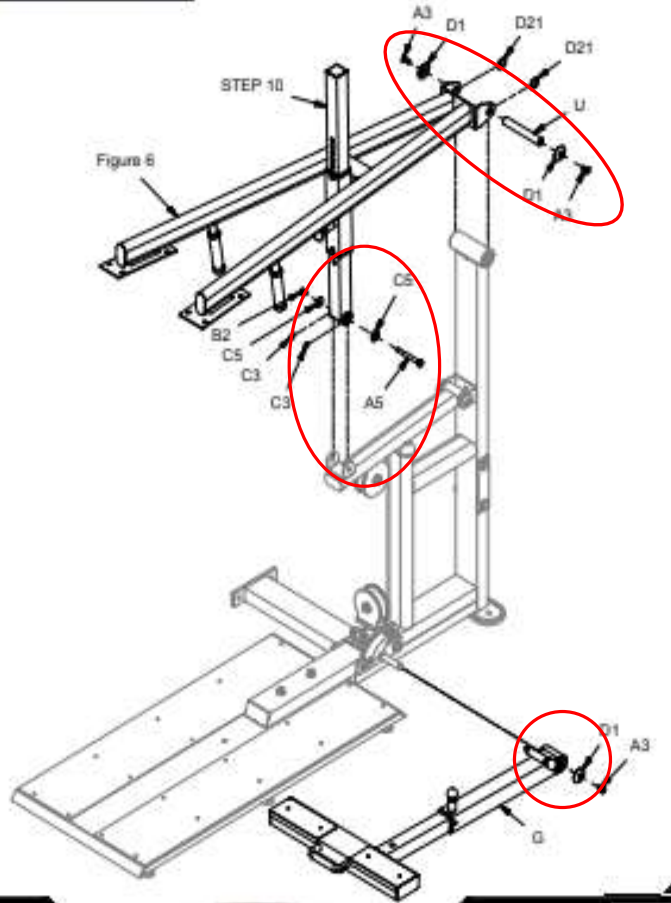

STEP 10

Figure 6

MCP-2200 ASSEMBLY INSTRUCTIONS

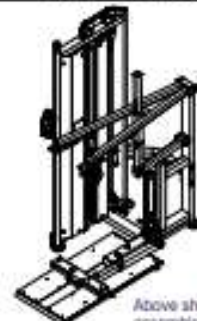

Above shows STEP 13 assembled and completed

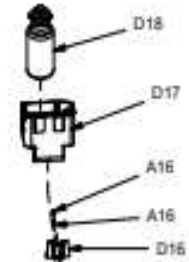

Post location



M6X12L ROUND BOLT X5
M6 WASHER Ø14X2

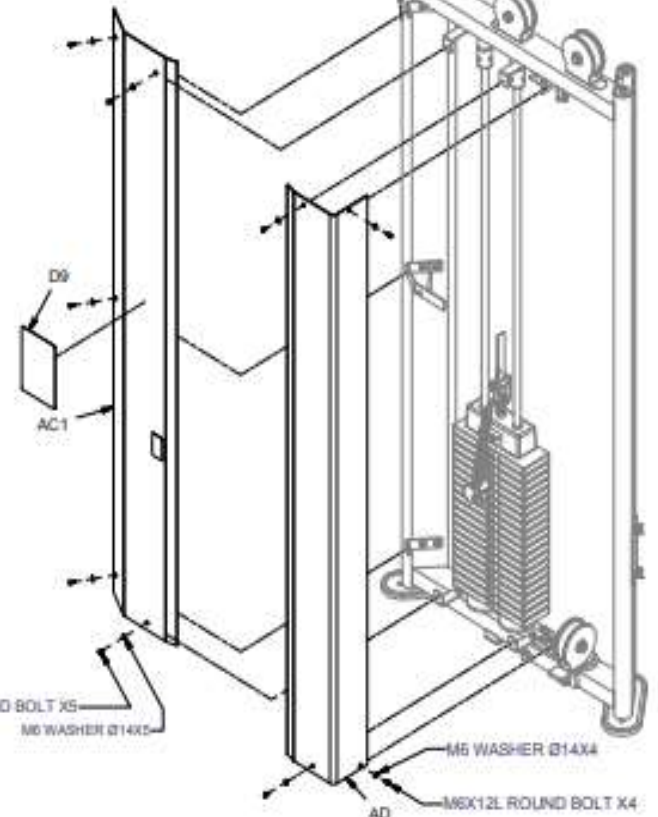

M5 WASHER Ø14X4

M6X12L ROUND BOLT X4

MCP-2200 ASSEMBLY INSTRUCTIONS



Above shows STEP 13 assembled and completed

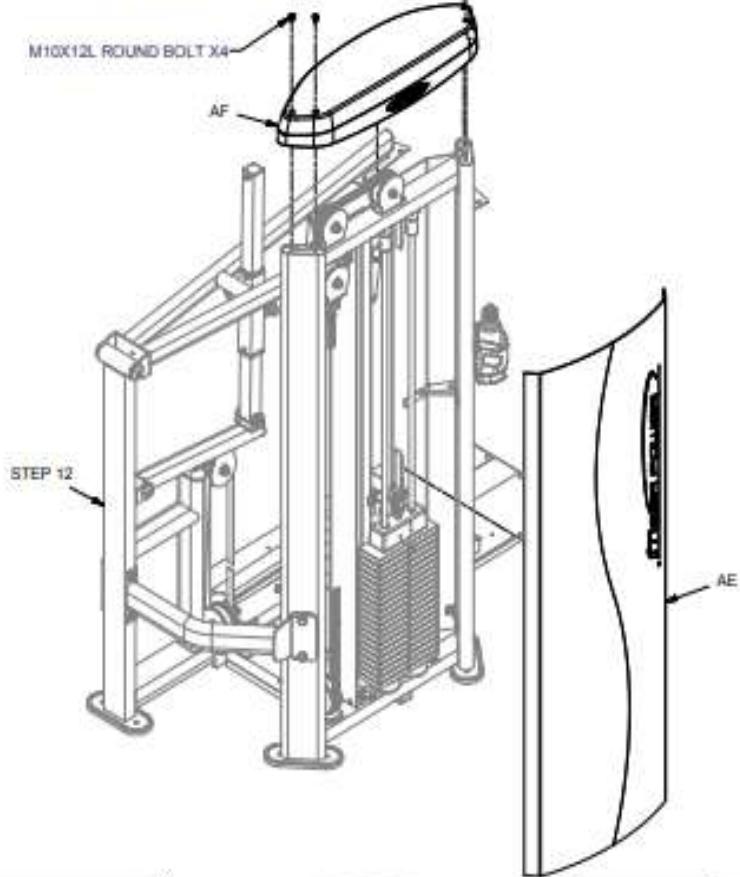

MCP-2200 ASSEMBLY INSTRUCTIONS

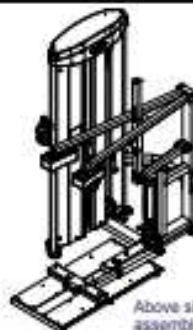

Above shows STEP 14 assembled and completed

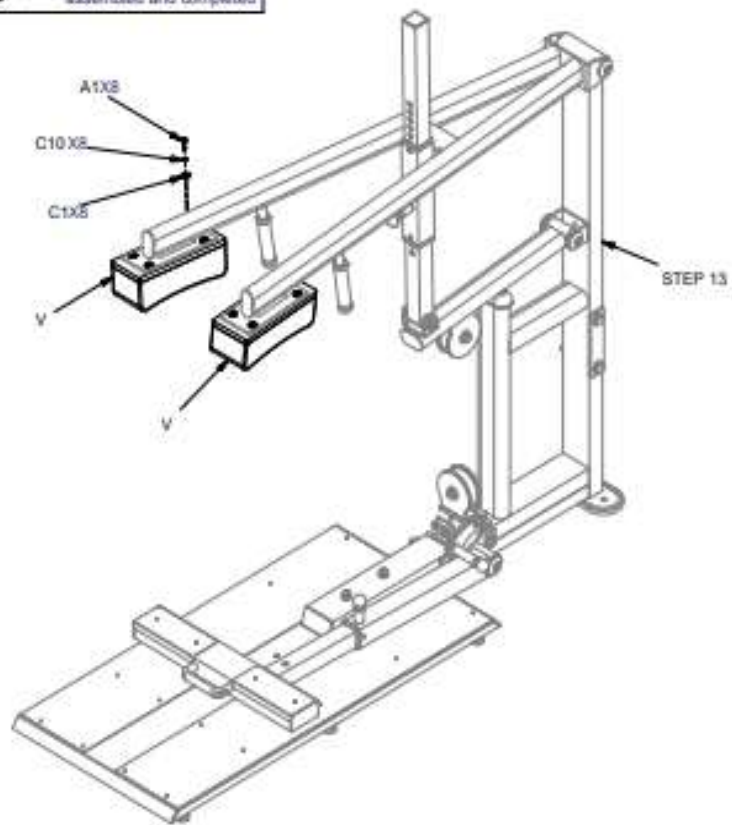

ASSEMBLY INSTRUCTIONS

Adjust Flat Belt Steps

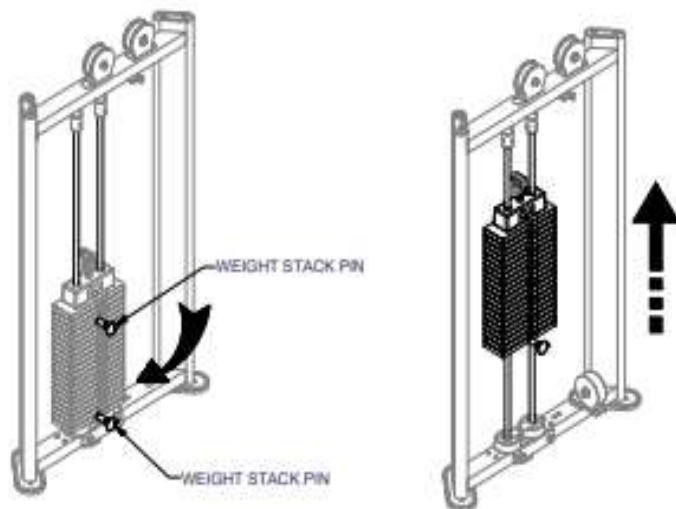

1. When installing flat belt, please put the weight stack pin into 4th weight stack. After installing flat belt, please put the weight stack pin into 20th weight stack.

2. When weight stack pin put into 20th weight stack, please do workout with the machine around 1 minute or 5-10 sets in order to extend the flat belt, flat belt will be loosed a little bit.

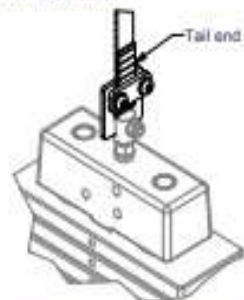

3. Pull end of flat belt as drawing showed to make the flat belt be tightened. (After using the machine 3 months to 6 months, please check flat belt. If the flat belt is loosed, please follow this step to tighten the belt again.)

Guide on Selector Rod Adjustment

STEP 1



Step 1
Place Selector Rod into Top Plate.
Then put selector pin into the weight plate to fix the rod.

STEP 2



Step 2
Screw the 3/8"x2"L Round Allen Head into Top Plate but not tighten it up.

STEP 3



Step 3
Place the selector pin to each weight plate (5, 10, 15, 20...) to check the smoothness.

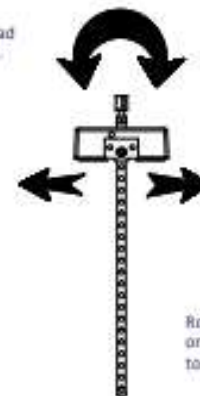

Rotate the Selector Rod slightly or move the 3/8"x2"L Round Allen Head to left and right and repeat Step 3.

MEGA POWER series
JUNGLE GYM series

| project | Part number | Name | Specification | Quantity | Remark |
|---------|------------------|-------------------------|-------------------------------|----------|--------|
| 1 | 38-200-CAP | round allen head | 3/8"X2"L round allen head-CAP | 1 | |
| 2 | 38-SPWAS 8732003 | 3/8" spring washer | | 1 | |
| 3 | 8210-216C | 20 hole Selector Rod | | 1 | |
| 4 | 8250-166 | pin | Ø7.9X137L | 1 | |
| 5 | 8250-162 | weight stack pin | Ø7X110L | 1 | |
| 6 | 8400-010 | 10LB weight stack plate | 102x220x280L 10LB | 20 | |
| 7 | 8400-033 | top plate | | 1 | |

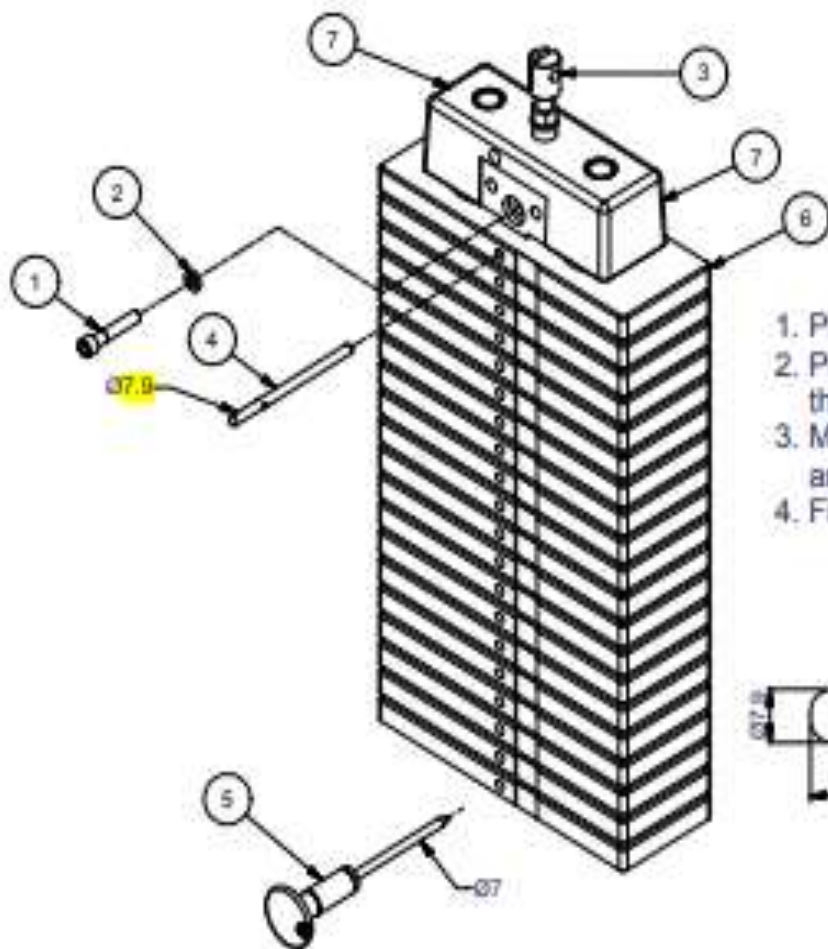

1. Place #4 - 8250-166 (pin) into the first weight plate.
2. Place #5 - 8250-162 (weight stack pin) into the the hole 20th of the weight stack.
3. Make sure #7 (top plate) cling to #6 (first weight plate) and fix in #1 - 3/8"X2"L screw and #2 - 3/8" spring washer.
4. Finally remove #5 - 8250-162 (weight stack pin) and use as usual.

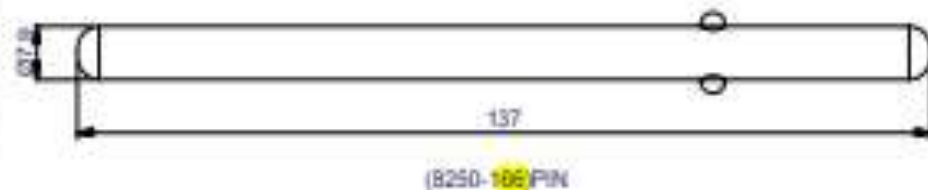

*Well done!

