

# \* MLC400B Maintenance



\* Customers can put some grease on pivot points (red circle place), with brass or gunmetal bushings.



WD-40多种规格





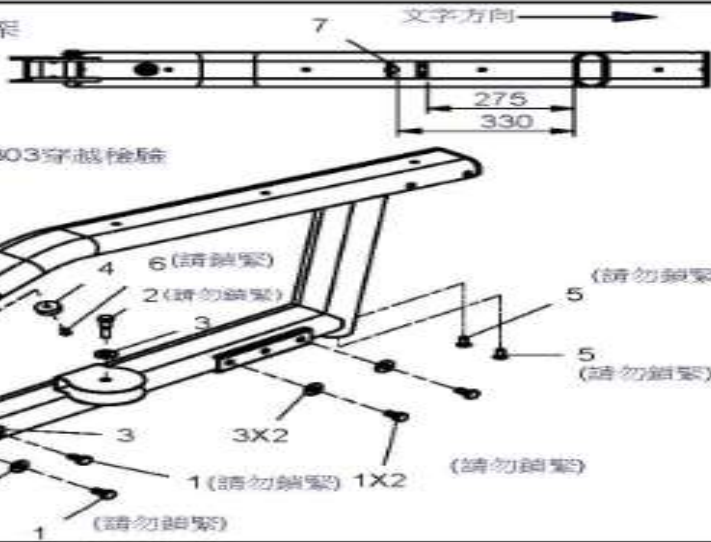
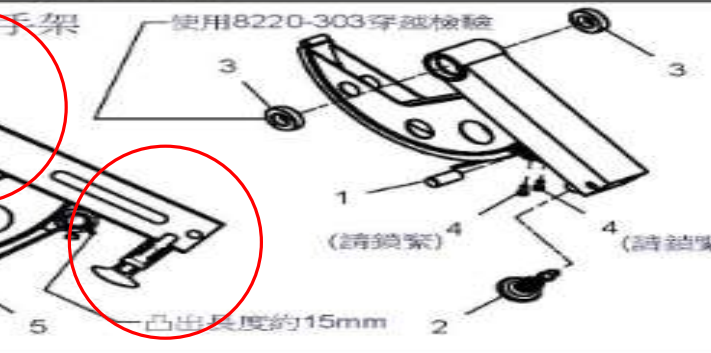
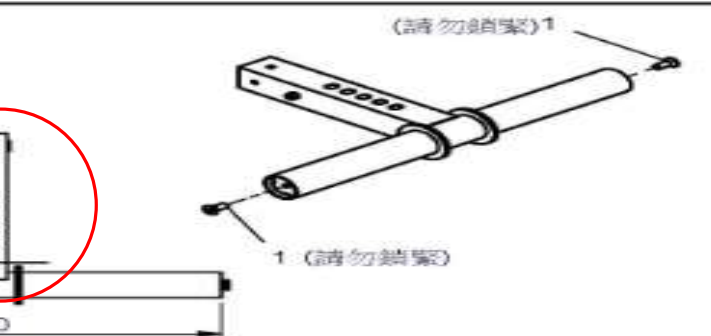

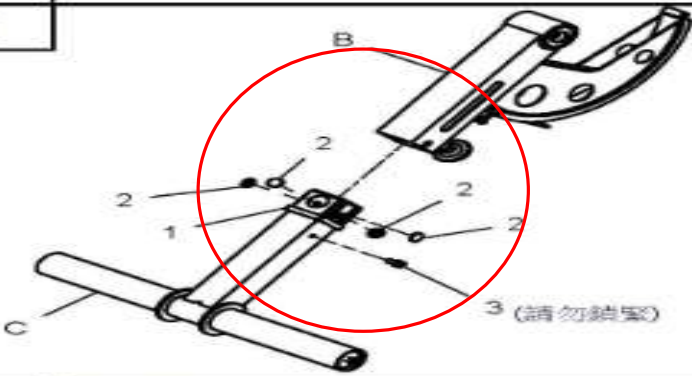
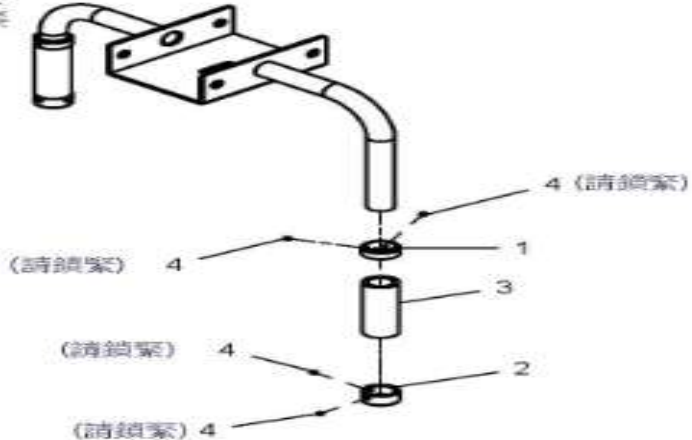
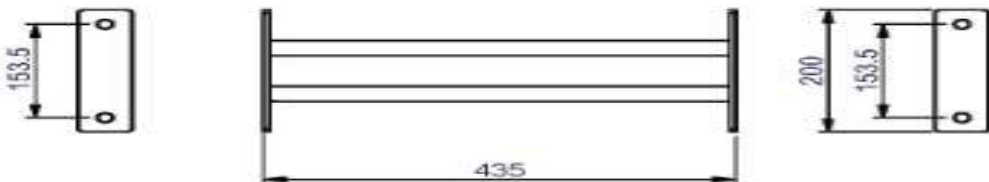
\* Let's maintain your machine!

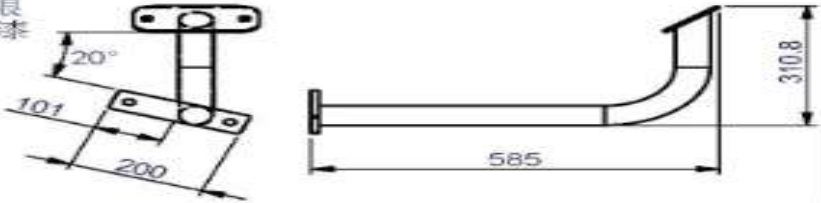
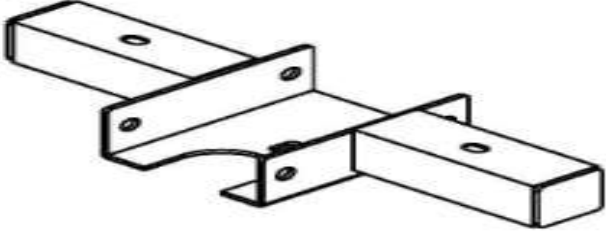
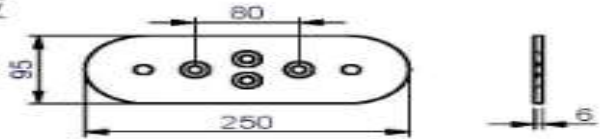
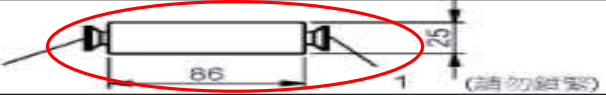
零件代碼	品名及圖案	用量	備註
20MLC400B-A 國標3124S-閃銀 國標KL0240明漆 二塗二烤	主架 	1SET	1.組立1/2"X1"L=4PCS 一般外六角螺絲 2.組立1/2"X2-1/4"L=1PCS 一般外六角螺絲 3.組立1/2"華司Ø34=5PCS 4.組9310-116橡膠圈=1PCS 5.組立M10X25L=2PCS 鉸形內六角螺絲 6.組立M8X16L=1PCS 平面頭內六角螺絲 7.黏貼9440-055台灣貼紙=1PCS
20MLC400B-B 國標3124S-閃銀 國標KL0240明漆 二塗二烤	扶手架 	1SET	1.組立8210-162軸心=1PCS Ø3/4"X40L 2.組立8250-066調整組=1PCS 3.組立8510-018軸承=2PCS 4.組立M6X16L=2PCS 圓頭內六角螺絲-CAP 5.FMLC400BA平皮帶=1PCS 長度4265mm
20MLC400B-C 國標3124S-閃銀 國標KL0240明漆 二塗二烤		1SET	1.組立M10X25L=2PCS 鉸形平頭內六角螺絲

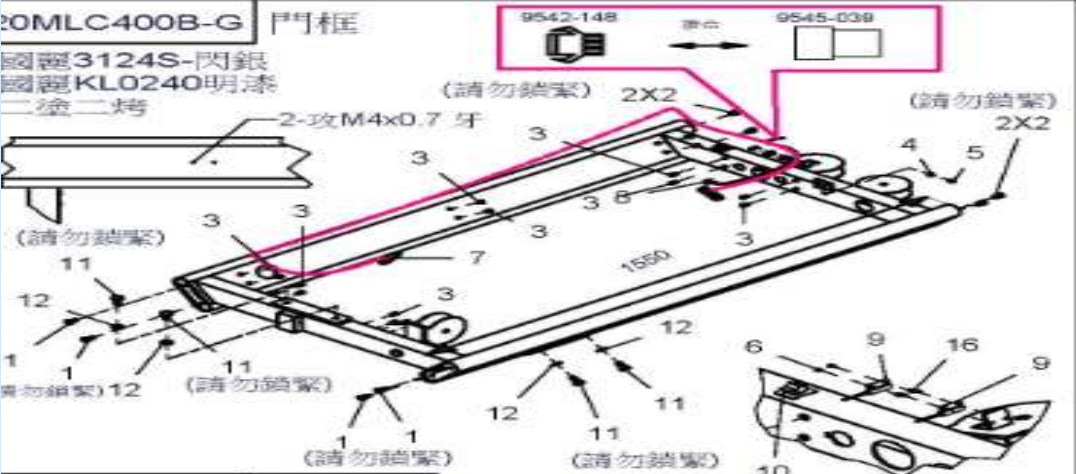
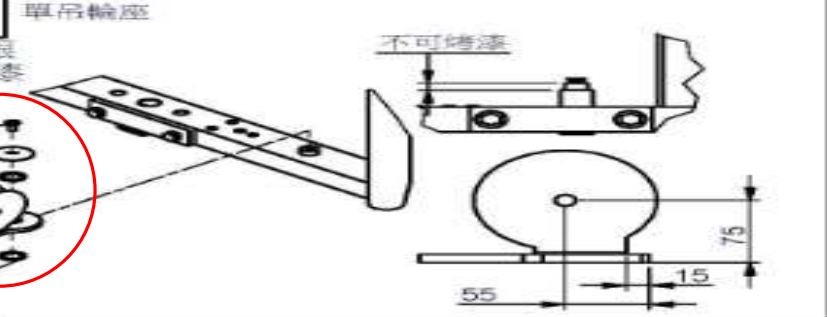
零件代碼	品名及圖案	用量	備註
總組立圖		1SET	1.組立9211-033雙層套=1PCS 2.組立9211-036按扣墊=4PCS 3.組立M8X15L=1PCS 圓頭內六角螺絲-CAP
20MLC400B-D 國麗3124S-閃銀 國麗KLO240明漆 二塗二烤	扶手架 	1SET	1.組立8130-250束子=2PCS 2.組立8890-006鐵套=2PCS 3.組立9182-113=2PCS 高密度把手 4.組立3/16"X3/16"L=4PCS 沉頭內六角螺絲
20MLC400B-E 國麗3124S-閃銀 國麗KLO240明漆 二塗二烤	連接桿 	1SET	

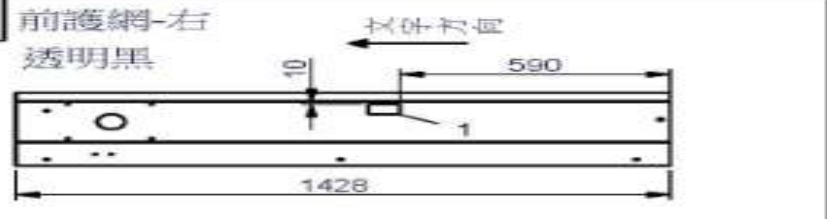
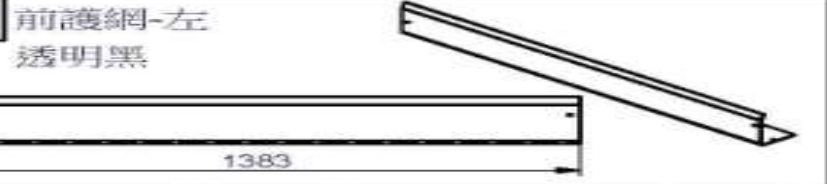
零件代碼	品名及圖案	用量	備註
20MLC400B-F	連接桿 國麗3124S-閃銀 國麗KLO240明漆 二塗二烤 	1SET	
20MLC400B-H	座墊管 國麗3124S-閃銀 國麗KLO240明漆 二塗二烤 	1SET	
8313-144	固定板 國麗3124S-閃銀 國麗KLO240明漆 二塗二烤 	1PCS	HLMLC400BA內箱
8220-303	軸心 電鍍 (請勿鎖緊) 1  (請勿鎖緊) 1	1SET	1.組立M10X25L=2PCS 錐形平頭內六角螺絲
9420-144	動作圖銘版	1PCS	1.9630-126氣泡=1PCS 160X460XB-平口
23MLC400BA	附件包	1SET	HLMLC400BA內箱
25MLC400BA	皮帶輪包	1SET	HLMLC400BA內箱
GMLC400BA	螺絲包	1SET	HLMLC400BA內箱
KMLC400B	說明書	1SET	HLMLC400BA內箱

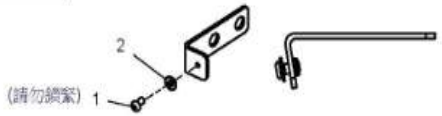
零件代碼	品名及圖案	用量	備註
20MLC400B-G 國麗3124S-閃銀 國麗KL0240明漆 二塗二烤	門框 	1SET	1.組立M10X25L=6PCS 推形平頭內六角螺絲 2.組立M10X12L=4PCS 圓頭內六角-CAP螺絲 3.M8拉釘(自備有孔)=16PCS 4.M8螺可Ø13=1PCS 5.M8X12L=1PCS 手圍國內六角螺絲 6.M3X6L=2PCS 手圍十字螺絲 7.組立9542-180=1PCS 訊號線(下接) 8.組立9542-148=1PCS 訊號線 9.組9545-039=1PCS 磁簧感應線 10.組立9260-023=2PCS 配線固定座1 11.組立1/2"X1"L=4PCS 一般外六角螺絲 12.組立1/2"螺可-Ø25=4PCS 13.組立9630-163 YS-8等式鉛筆桿=1PCS 14.組立8130-231端蓋=1PCS 15.組立8520-008銅螺可=2PCS 16.組立9215-021=2PCS 塑膠螺柱
6640-011 國麗3124S-閃銀 國麗KL0240明漆 二塗二烤	單吊輪座 	1SET	
9220-015 壓克力護網	前護網-右 透明黑 	1PCS	1.貼9440-117防夾手貼紙=1PCS
9220-016 壓克力護網	前護網-左 透明黑 	1PCS	

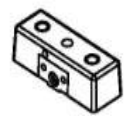
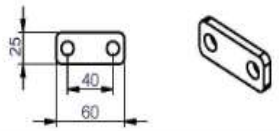
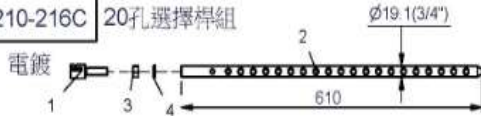
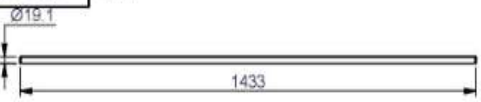
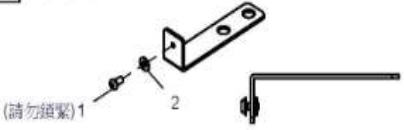
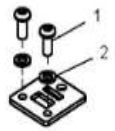
零件代碼	品名及圖案	用量	備註	零件代碼	品名及圖案	用量	備註
9220-023	護網 壓克力護網 透明黑	1PCS		8331-058	固定片 	3SET	1.組立M6X12L 半圓頭內六角螺絲=3PCS 2.組立M6螺可-Ø13=3PCS  HLMLC400BB內箱
9211-148	上蓋 	1SET	1.貼9441-370=2PCS 起標(Steelex)  H9211148內箱	8313-144	固定片 	2PCS	HLMLC400BB內箱
8400-033	選擇上片 	1SET	HLMLC400BB內箱	8311-117	固定片 	1PCS	HLMLC400BB內箱
8210-216C	20孔選擇桿組 	1SET	1.組立8260-076固定桿=1PCS 2.組立8210-216 20孔選擇桿=1PCS 3.組立1/2"螺帽=1PCS 4.組立1/2"彈簧華司=1PCS	8280-042	導桿 	2PCS	1.安裝9180-028特固籠=2PCS Ø48X31X75L
8331-057	固定片 	4SET	1.組立M6X12L=4PCS 半圓頭內六角螺絲 2.組立M6螺可-Ø13=4PCS  HLMLC400BB內箱	23MLC400BB	附件包	1SET	HLMLC400BB內箱
8313-169	固定片 電鍍 	1PCS	1.組立M10X25L 半圓頭內六角螺絲=2PCS 2.組立M10彈簧華司=2PCS  HLMLC400BB內箱	23MDCUP	附件包-CUP	1SET	HLMLC400BB內箱
				25MLC400BB	皮帶輪包	1SET	HLMLC400BB內箱
				GMLC400BB	螺絲包	1SET	HLMLC400BB內箱
				KMD	操作手冊	1SET	HLMLC400BB內箱

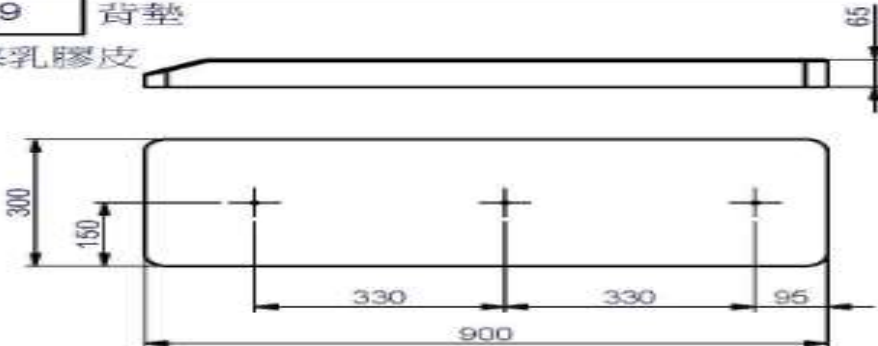
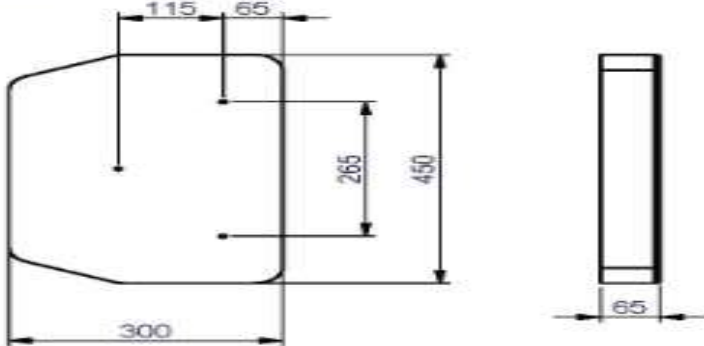
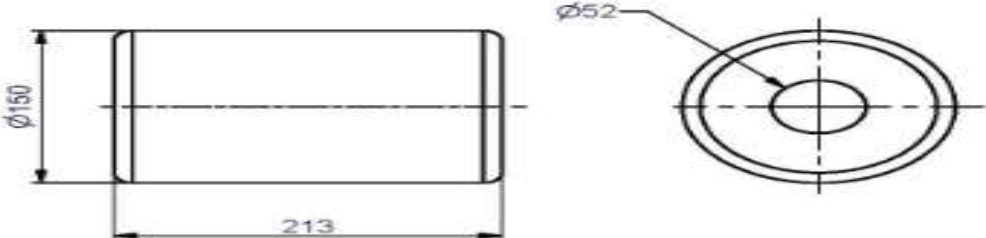
零件代碼	品名及圖案	用量	備註
9111-109 黑色耐寒乳膠皮	背墊 	1SET	
9121-119 黑色耐寒乳膠皮	坐墊 	1SET	
9161-078 黑色PU發泡	泡棉組 	2SET	

# MLC400B ASSEMBLY INSTRUCTIONS

## HARDWARE ILLUSTRATION

D1. Ø60 CAP COVER(8130-231)	-----	[2PCS]
D2. Ø76 CAP COVER(8130-236)	-----	[2PCS]
D3. Ø120XØ51X3t NYLON WASHER(9214-039)	-----	[4PCS]
D4. 108X15tX263L RUBBER PAD(9310-075)	-----	[1PCS]
D5. Ø115X50L PULLEY-NO MAGNET(9213-042B)	-----	[2PCS]
D6. 4295mm BELT (FMLC400BA1)	-----	[1PCS]

D1.



D2.



D3.



D4.



D5.

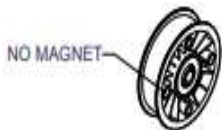

D6.



# MLC400B ASSEMBLY INSTRUCTIONS

## FARME HARDWARE ILLUSTRATION

DD1. Ø3/4" SHAFT COLLAR(9211-147)	-----	[2PCS]
DD2. Ø4" RUBBER DOUNT(9310-017)	-----	[2PCS]
DD3. 108X14.5tX263L RUBBER PAD(9310-075)	-----	[2PCS]
DD4. Ø115X50L PULLEY-NO MAGNET(9213-042B)	-----	[3PCS]
DD6. BOTTLE BRACKET(8388-025)	-----	[1PCS]
DD7. BOTTLE RACK(9260-320)	-----	[1PCS]
DD8. BOTTLE(9260-123)	-----	[1PCS]
DD9. TOP PLATE(8400-033)	-----	[1PCS]
DD10. Ø3/4" SHAFT COLLAR(9211-167)	-----	[2PCS]
DD11. WEIGHT SELECTOR BAR(8210-216C)	-----	[1PCS]

DD1.



DD2.



DD3.



DD4.

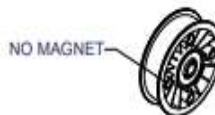

DD6.



DD7.



DD8.



DD9.

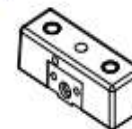

DD10.



DD11.



# MLC400B ASSEMBLY INSTRUCTIONS

## PARTS ILLUSTRATION SHEET

A [1SET]

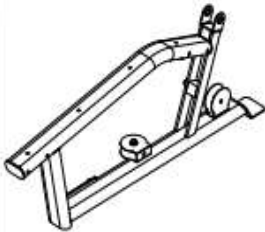

B [1SET]

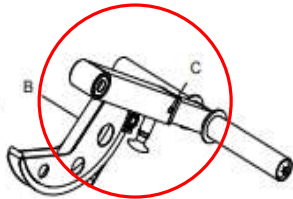

D [1SET]

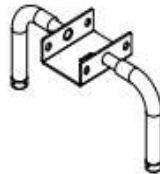

E [1SET]



F [1SET]



H [1SET]

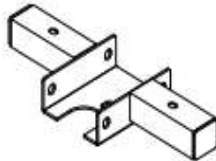

I [1SET]  
8313-144



J [1SET]  
9111-109

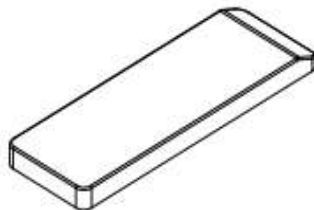

K [1SET]  
9121-119



L [2PCS]  
9161-078



M [1PCS]  
9420-144



N [1SET]  
8220-203



# MLC400B ASSEMBLY INSTRUCTIONS

## FARME PARTS ILLUSTRATION SHEET

AA1 [1SET]

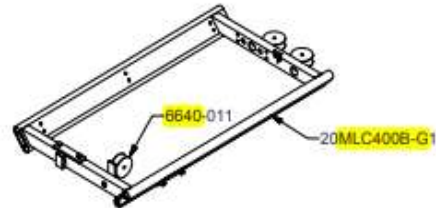

AC [1PCS]  
9220-016

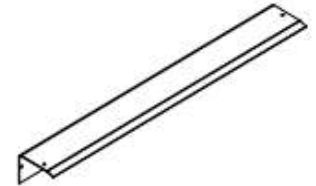

AD1 [1PCS]  
9220-052

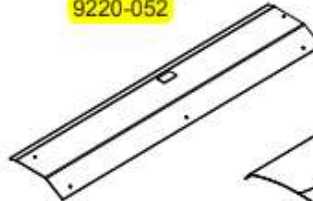

AE [1SET]  
9220-023

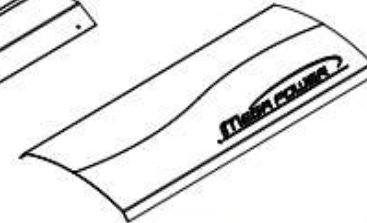

AF [1SET]  
9211-148



AG [4SET]  
8331-057



AH [1SET]  
8313-169



AI [2PCS]  
8280-042  
Ø3/4"X1433L



AJ [1PCS]  
8331-056



AK [3SET]  
8331-058



AL [2PCS]  
8313-144



# MLC400B ASSEMBLY INSTRUCTIONS

## FARME PARTS ILLUSTRATION SHEET

AO [1PCS]  
8311-117

AR [1PCS]  
8311-194

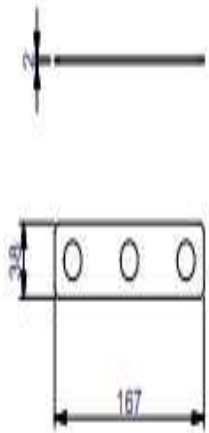
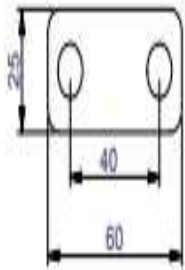

# MLC400B ASSEMBLY INSTRUCTIONS

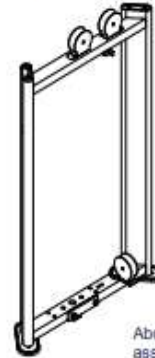

Above shows STEP 1  
assembled and completed

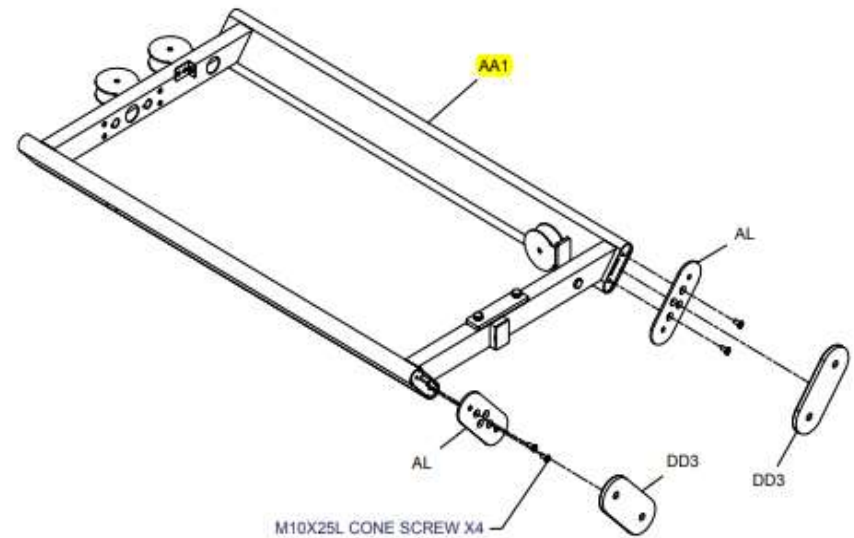



# MLC400B ASSEMBLY INSTRUCTIONS

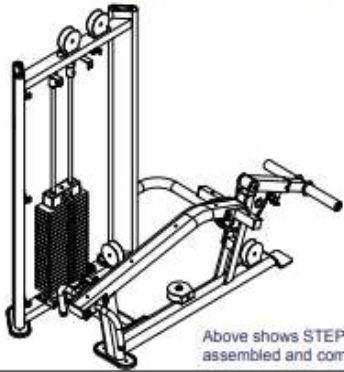

Above shows STEP 3 assembled and completed

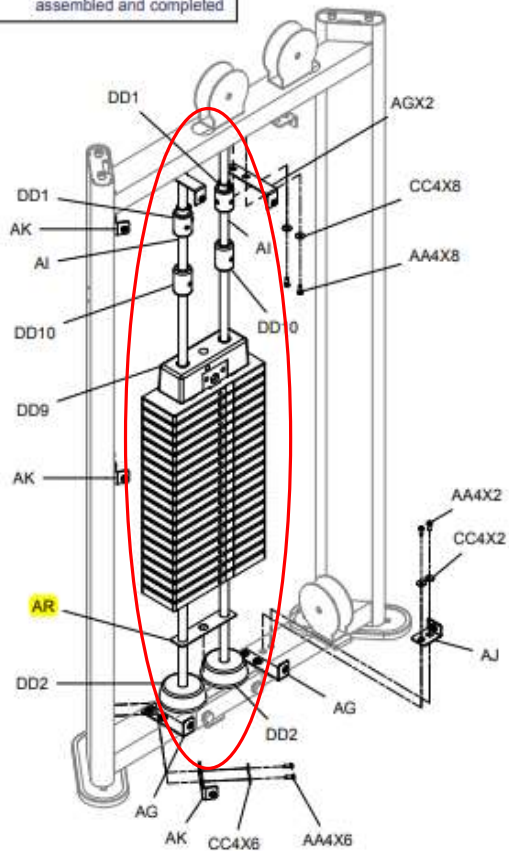

# MLC400B ASSEMBLY INSTRUCTIONS

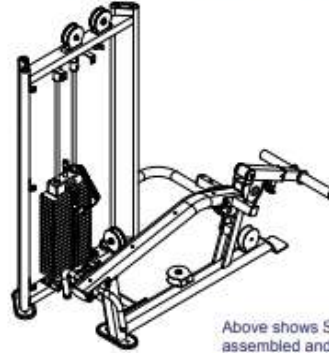

Above shows STEP 5 assembled and completed

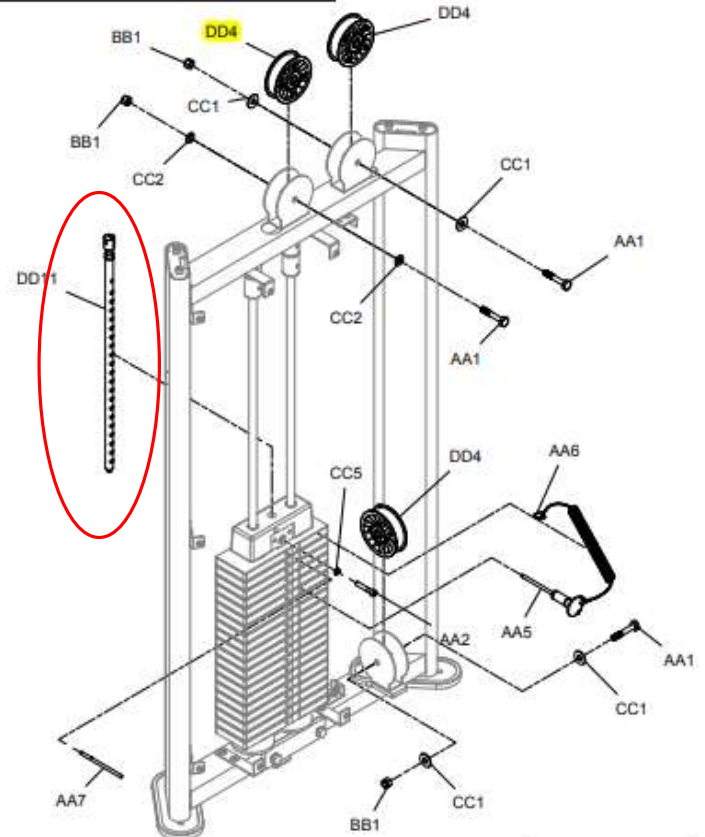

# MLC400B ASSEMBLY INSTRUCTIONS

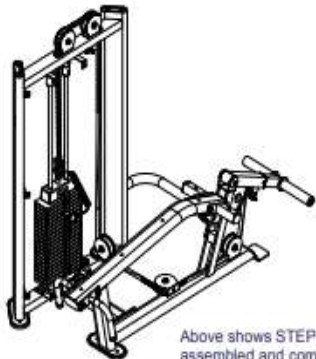

Above shows STEP 6 assembled and completed

The tread side should be outward

M10X25L ROUND BOLT X2  
M10 SPRING WASHER X2

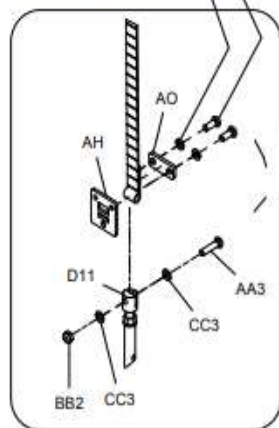

**Adjust Belt Procedure:**

1. Lift the selector rod a little and then insert the pin between first weight stack and top plate (Do not insert through the first hole of the rod), and there are 7 mm gap between top plate and first weight stack.
2. Adjust the belt to have proper tension and then tighten the belt clamps
3. Remove the pin and let the top plate fall on the first weight plate.

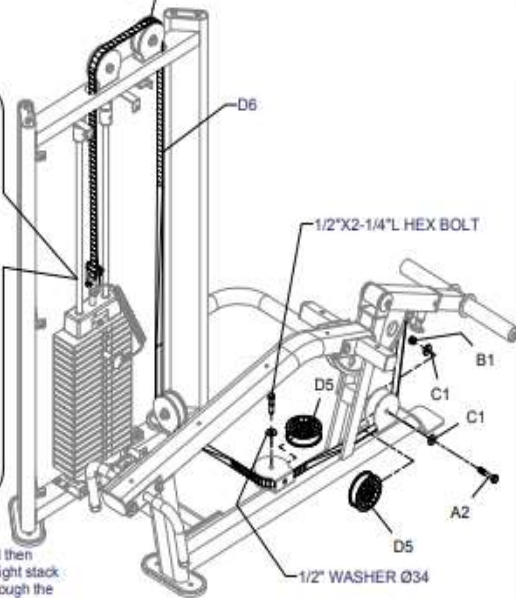
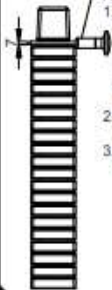

# MLC400B ASSEMBLY INSTRUCTIONS

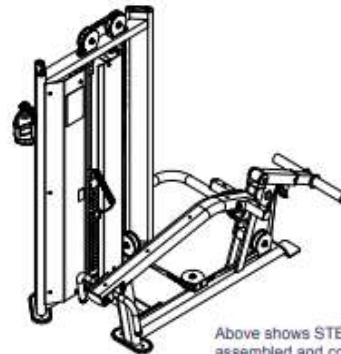

Above shows STEP 8 assembled and completed

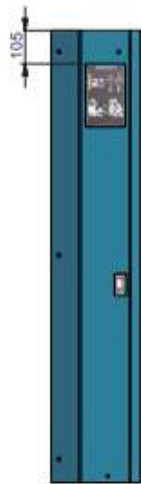
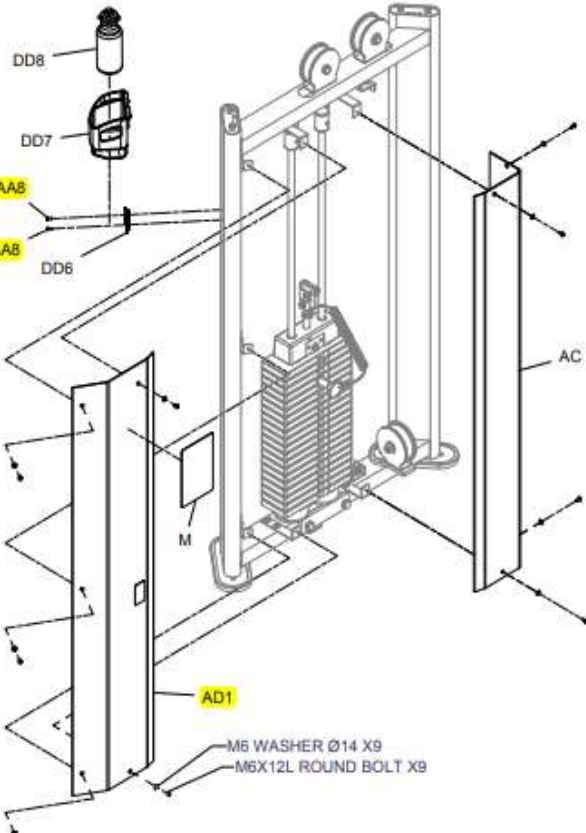

# MLC400B ASSEMBLY INSTRUCTIONS

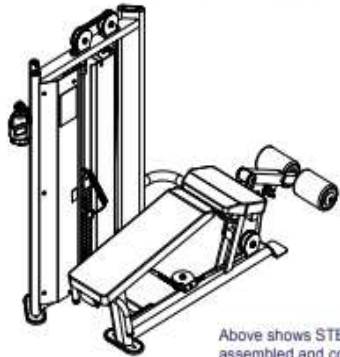

Above shows STEP 8 assembled and completed

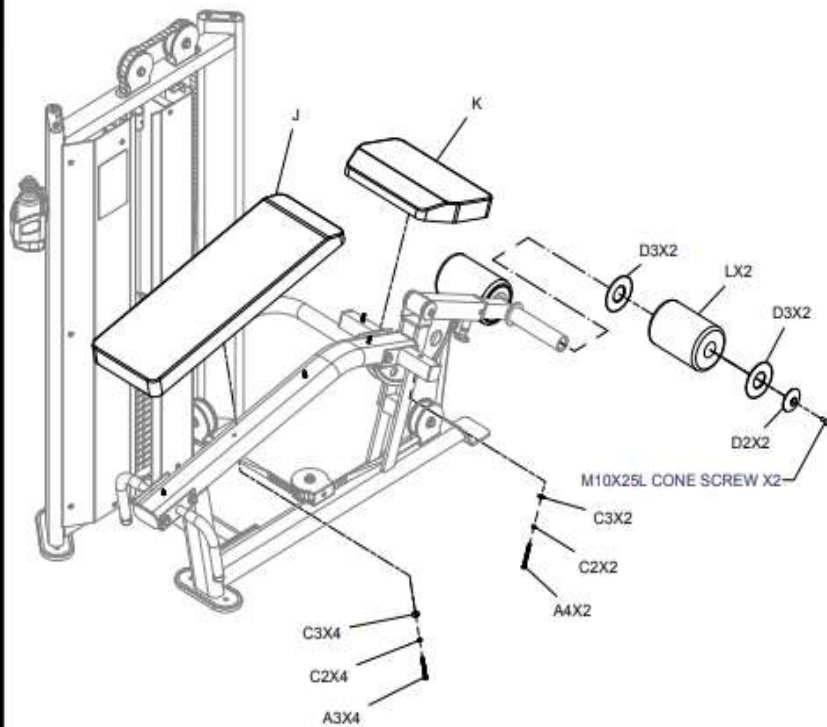

# MLC400B ASSEMBLY INSTRUCTIONS

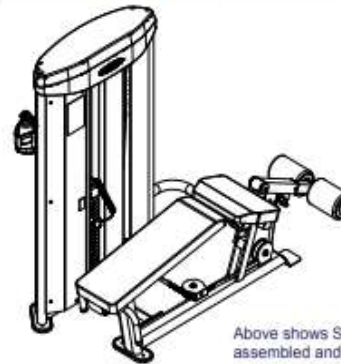

Above shows STEP 9 assembled and completed

M10X12L ROUND INNER HEAD X4

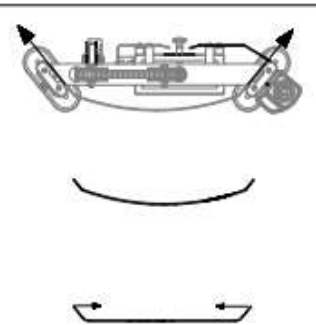
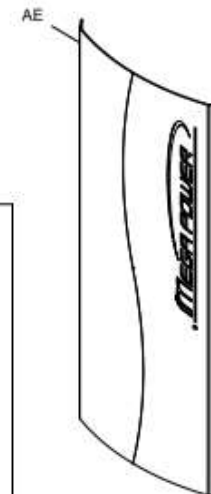
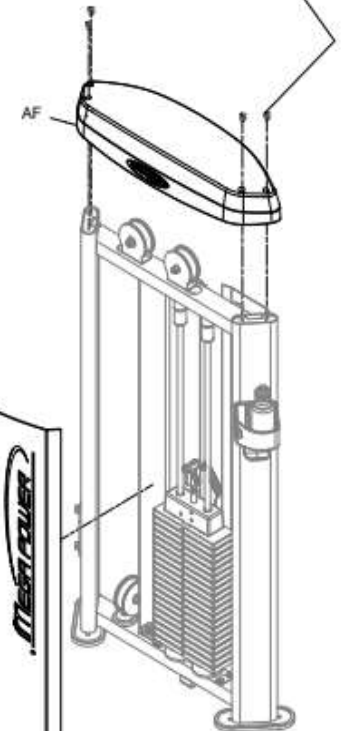

Note: When installing the shroud (AE), push both sides of the shroud toward center in order to bend it a little. After insert it to the door frame and then releasing it. The shroud will be locked on the door frame.

# ASSEMBLY INSTRUCTIONS

## Adjust Flat Belt Steps

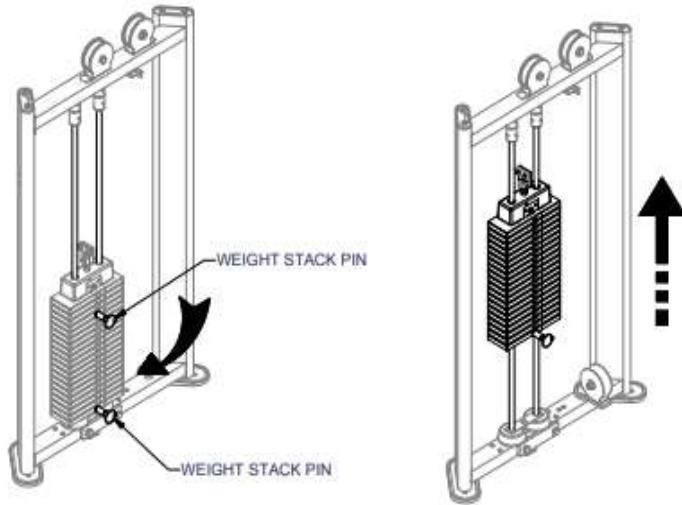

1. When installing flat belt, please put the weight stack pin into 4<sup>th</sup> weight stack. After installing flat belt, please put the weight stack pin into 20<sup>th</sup> weight stack.

2. When weight stack pin put into 20<sup>th</sup> weight stack, please do workout with the machine around 1 minute or 5-10 sets in order to extend the flat belt, flat belt will be loosed a little bit.

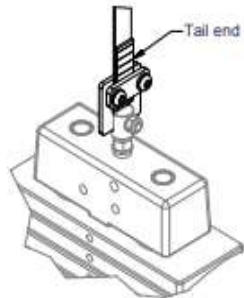

3. Pull end of flat belt as drawing showed to make the flat belt be tightened. (After using the machine 3 months to 6 months, please check flat belt. If the flat belt is loosed, please follow this step to tighten the belt again.)

## Guide on Selector Rod Adjustment

### STEP 1

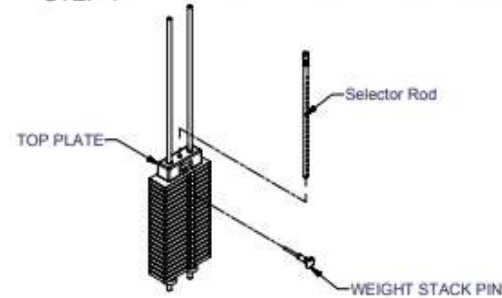

Step 1  
Place Selector Rod into Top Plate.  
Then put selector pin into the weight plate to fix the rod.

### STEP 2

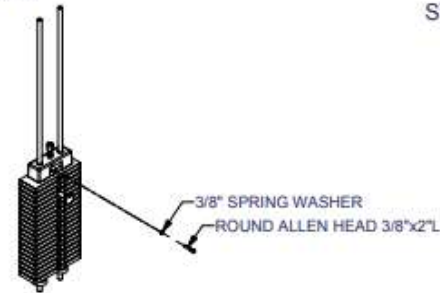

Step 2  
Screw the 3/8"x2"L Round Allen Head Into Top Plate but not tighten it up.

### STEP 3

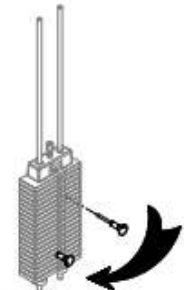

Step 3  
Place the selector pin to each weight plate (5,10,15,20...) to check the smoothness.

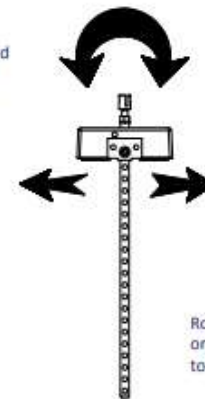

Rotate the Selector Rod slightly or move the 3/8"x2"L Round Allen Head to left and right and repeat Step 3.

# MEGA POWER series JUNGLE GYM series

project	Part number	Name	Specification	Quantity	Remark
1	38-200 CAP	round allen head	3/8"X2"L round allen head-CAP	1	
2	38-SPWAS 8732003	3/8" spring washer		1	
3	8210-216C	20 hole Selector Rod		1	
4	8250-166	pin	Ø7.9X137L	1	
5	8250-162	weight stack pin	Ø7X110L	1	
6	8400-010	10LB weight stack plate	102x22x280L 10LB	20	
7	8400-033	top plate		1	

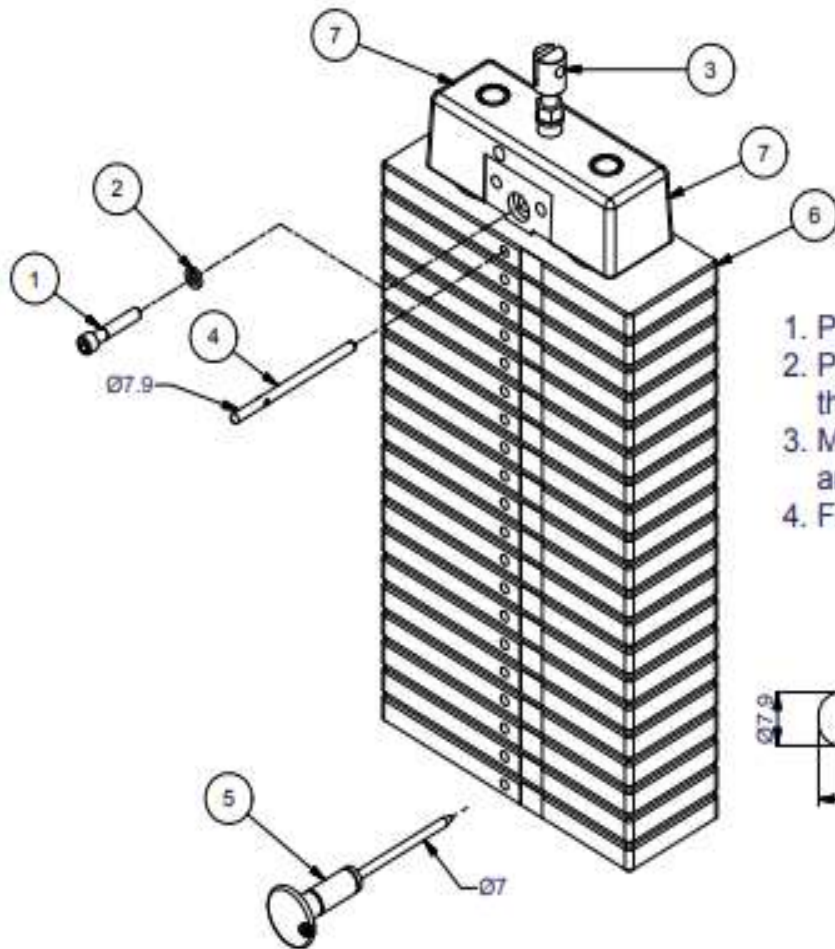

1. Place #4 - 8250-166 (pin) into the first weight plate.
2. Place #5 - 8250-162 (weight stack pin) into the the hole 20th of the weight stack.
3. Make sure #7 (top plate) cling to #6 (first weight plate) and fix in #1 - 3/8"X2"L screw and #2 - 3/8" spring washer.
4. Finally remove #5 - 8250-162 (weight stack pin) and use as usual.

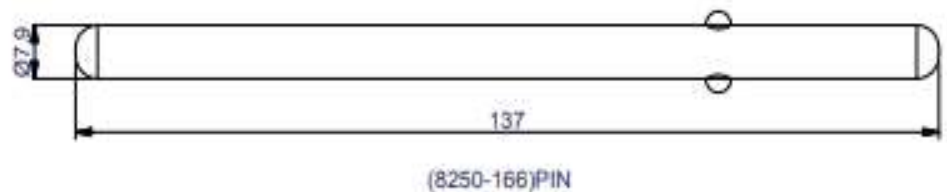

\*Well done!

