

# \*MBC600 Maintenance



\* Customers can put some grease on pivot points (red circle place), with brass or gunmetal bushings.







WD-40多种规格

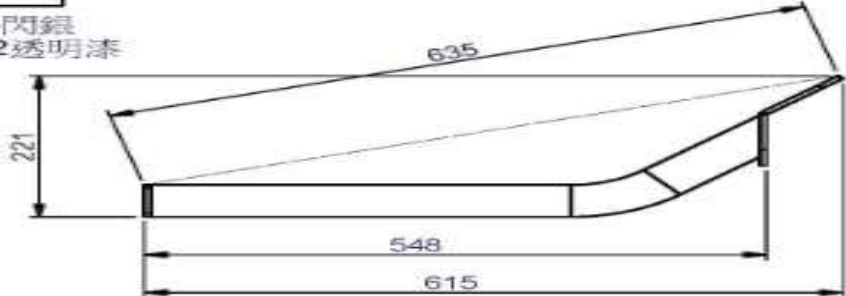
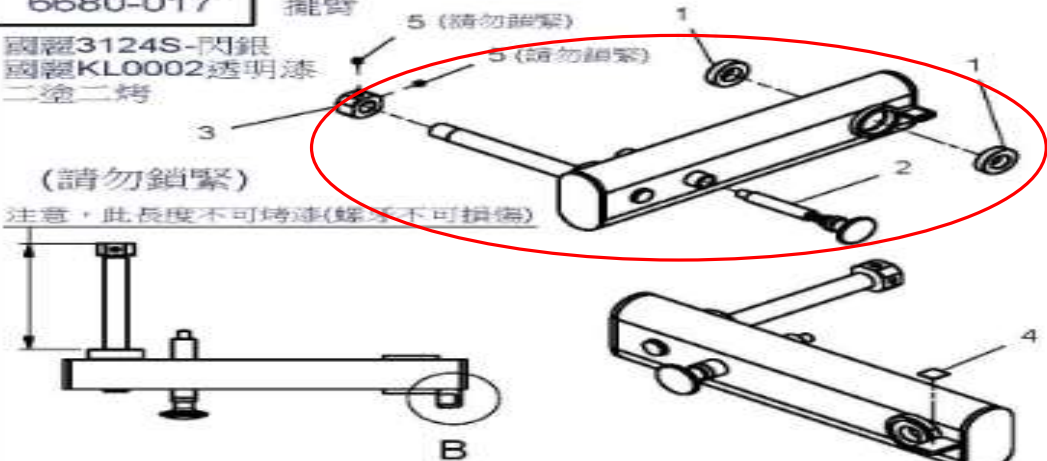
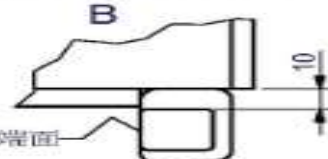
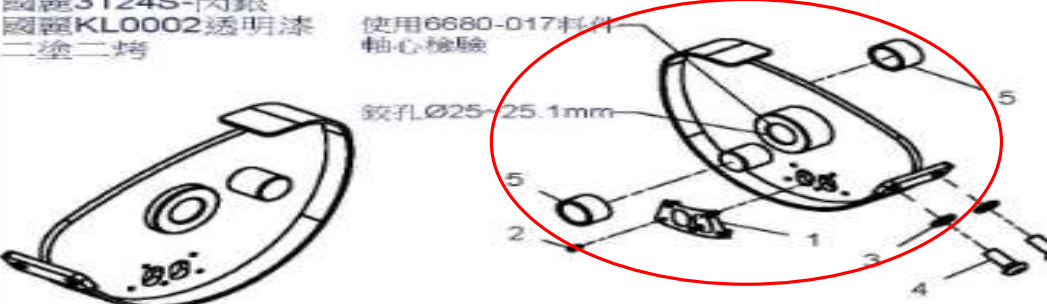

\* Let's maintain your machine!

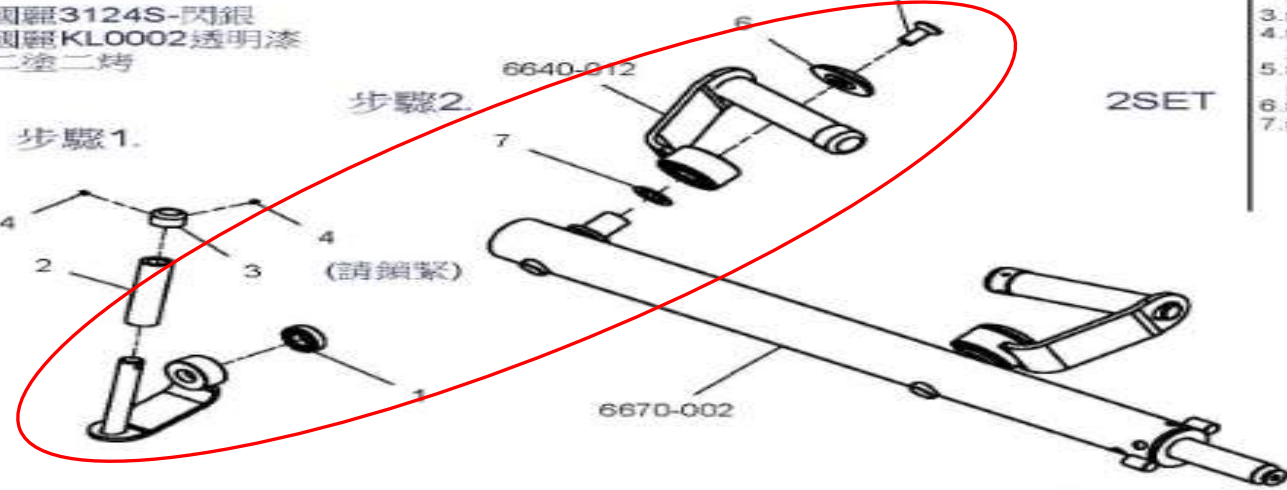

零件代碼	品名及圖案	用量	備註
6621-003 國麗3124S-閃銀 國麗KL0002透明漆 二塗二烤 20MRM1700-D (280229) 國邦790-49153F1HT-深灰	主架 		1.組立8250-101調整組=1PCS 2.組立8520-001鋼套=2PCS 3.組立8830-013氣壓棒=1PCS 4.組立9211-036按扣墊=2PCS 5.組立9211-118按扣墊=2PCS 6.組立9211-107雙層套=1PCS 7.組立1/2"X1"L=4PCS 一般外六角頭螺絲 8.組立1/2"X3"L=1PCS 一般外六角頭螺絲 9.組立1/2"尼帽=1PCS 10.組立1/2"華可Ø25=6PCS 11.組立3/8"X2-1/4"L=1PCS 一般外六角頭螺絲 12.組立3/8"尼帽=2PCS 13.組立3/8"華可Ø16=4PCS 14.組立3/8"X2-1/2"L=1PCS 一般外六角頭螺絲 15.組立M10X25L=4PCS 錐形內六角螺絲 16.貼9440-055貼紙=1PCS 17.貼工單貼紙=1PCS 18.貼9440-314認證貼紙=1PCS
6650-005 國麗3124S-閃銀 國麗KL0002透明漆 二塗二烤 6621-003 (請勿鎖緊) (請勿鎖緊)	座墊架 	1SET	
6630-005 國麗3124S-閃銀 國麗KL0002透明漆 二塗二烤	連接桿 	1SET	HLMBC600A內箱 適用於： MBC-600；MTE-1200

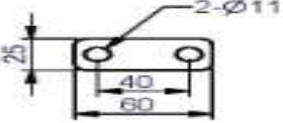

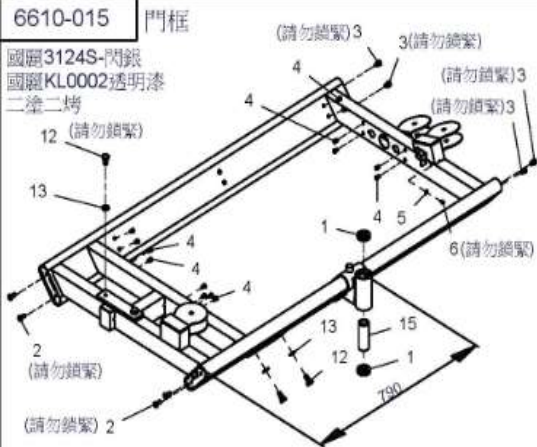
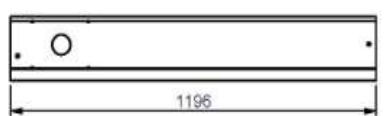
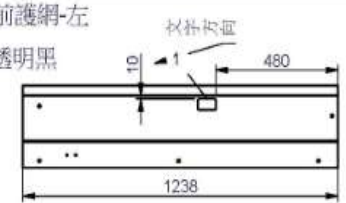

零件代碼	品名及圖案	用量	備註
6630-004	連接桿 國標3124S-閃銀 國標KL0002透明漆 二塗二烤 	1SET	<div style="border: 1px solid black; border-radius: 50%; width: 100px; height: 100px; display: flex; align-items: center; justify-content: center; margin: 20px auto;">             工作連絡單 100045           </div> 適用於： MBC-600 · MTE-1200
6680-017	擺臂 國標3124S-閃銀 國標KL0002透明漆 二塗二烤  <p>(請勿鎖緊)</p> <p>注意·此長度不可誇連(螺絲不可損傷)</p>	1SET	<ol style="list-style-type: none"> <li>1.組立8510-018軸承=2PCS</li> <li>2.組立8250-095調整組=1PCS</li> <li>3.組立8130-288固定套=1PCS 40X23X40</li> <li>4.貼9440-256貼紙=1PCS</li> <li>5.M8X8L=2PCS 沉頭內六角螺絲+耐落膠</li> </ol>  HLMBC600A內箱
6680-016	調整片 國標3124S-閃銀 國標KL0002透明漆 二塗二烤 使用6680-017料件 軸心檢驗  <p>鉸孔<math>\varnothing</math>25-25.1mm</p>	1SET	<ol style="list-style-type: none"> <li>1.組立9440-236貼紙=1PCS</li> <li>2.組立435(4-3)拉釘=5PCS</li> <li>3.組立M10彈簧華可=2PCS</li> <li>4.組立M10X25L=2PCS 半圓頭內六角螺絲</li> <li>5.組立9219-009=2PCS 阻擋墊<math>\varnothing</math>31.4X3TX18L</li> </ol> HLMBC600A內箱

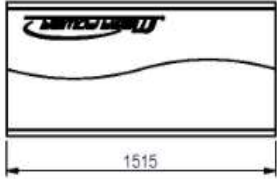
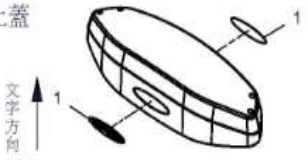
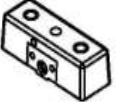
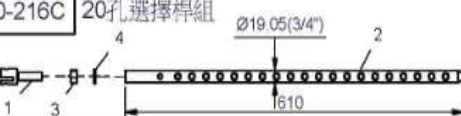

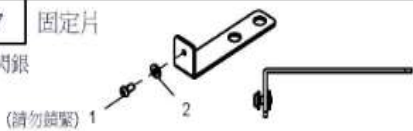
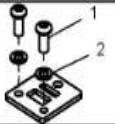
零件代碼	品名及圖案	用量	備註
6670-002 國麗3124S-閃銀 國麗KL0002透明漆 二塗二烤	扶手架 用8510-018軸承檢驗 此處不可烤漆 此處不可烤漆 此處不可烤漆 	1SET	1.組立M10X25L=1PCS 錐形內六角螺絲 <div style="border: 1px solid black; border-radius: 50%; padding: 10px; text-align: center; margin: 10px auto; width: 80%;"> <b>設變車號</b>              2015030005           </div>
6640-012 國麗3124S-閃銀 國麗KL0002透明漆 二塗二烤	扶手架 (注意! 請鎖緊加耐落膠) 6640-012 6670-002 步驟1. 步驟2. (請鎖緊) 	2SET	1.組立8510-010軸承=2PCS 2.組立9162-110=2PCS PVC浸漬把手Ø19X5tX110L 3.組立8890-067鐵套=2PCS 4.組立3/16"X3/16"L=4PCS 沉頭內六角螺絲 5.組立M10X25L=2PCS 錐形內六角螺絲(耐落膠) 6.組立8130-131端蓋=2PCS 7.組立8520-007銅華司=2PCS
8313-144 國麗3124S-閃銀 國麗KL0002透明漆 二塗二烤	固定片 	1PCS	HLMBC600A內箱
8311-117 國麗3124S-閃銀 國麗KL0002透明漆 二塗二烤	固定片 	1PCS	HLMBC600A內箱

零件代碼	品名及圖案	用量	備註
9420-102	動作圖銘板	1PCS	9630-126氣泡袋X1 160X460XB-平口
23MBC600A	附件包	1SET	HLMBC600A內箱
FMBC6001	皮帶包	1SET	HLMBC600A內箱
GMBC600A	螺絲包	1SET	HLMBC600A內箱
KMBC600	說明書	1SET	
			1.9180-027特固龍=6PCS Ø65X45X215L 2.9630-009束帶=5PCS  4.9630176蜂巢紙=8PCS 45HX70X30

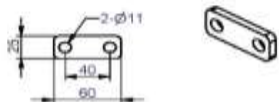
零件代碼	品名及圖案	用量	備註
6610-015	門框 國麗3124S-閃銀 國麗KL0002透明漆 二塗二烤 	1SET	1.組立B510-018=2PCS 6005ZZ軸承 2.組立M10X25L=4PCS 錐形內六角螺絲 3.組立M10X12L=4PCS 圓頭內六角-CAP螺絲 4.M6拉桿(自體有花)=18PCS 5.M6華司Ø13=1PCS 6.M6X12L=1PCS 半圓頭內六角螺絲 7. 8. 9. 10. 11. 12.組立1/2"X1"L=4PCS 一般外六角螺絲 13.組立1/2"華司-Ø25=4PCS 14. 15.組立8130-289固定套=1PCS Ø38XØ25.8X107L 16.
9220-020	前護網-右 壓克力護網 透明黑 	1PCS	<div style="border: 1px solid black; border-radius: 50%; padding: 10px; display: inline-block;"> <b>設變單號</b>            2019030004         </div>
9220-019	前護網-左 壓克力護網 透明黑 	1PCS	1.起9440-117防夾手貼紙=1PCS

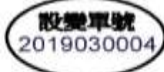
零件代碼	品名及圖案	用量	備註
9220-023	護網 壓克力護網 透明黑	1PCS	
			
9211-148	上蓋	1SET	1. 貼9441-370=2PCS 紙標(Steefflex)
			H9211148內箱
8400-033	選擇上片	1SET	
			HLMBC600B內箱
8210-216C	20孔選擇桿組	1SET	1. 組立8260-076固定桿=1PCS 2. 組立8210-216 20孔選擇桿=1PCS 3. 組立1/2"彈簧=1PCS 4. 組立1/2"彈簧華司=1PCS
電鍍			
			
8331-057	固定片	4SET	1. 組立M6X12L=4PCS 半圓頭內六角螺絲 2. 組立M6華司-Ø13=4PCS
國麗3124S-閃銀			HLMBC600B內箱
8313-169	固定片	1PCS	1. 組立M10X25L 半圓頭內六角螺絲=2PCS 2. 組立M10彈簧華司=2PCS
電鍍			HLMBC600B內箱

零件代碼	品名及圖案	用量	備註
8331-058	固定片	3SET	1. 組立M6X12L 半圓頭內六角螺絲=3PCS 2. 組立M6華司-Ø13=3PCS
國麗3124S-閃銀			HLMBC600B內箱
8313-144	固定片	2PCS	
國麗3124S-閃銀 國麗KL0002透明漆 二塗二烤			HLMBC600B內箱
8311-117	固定片	1PCS	
國麗3124S-閃銀 國麗KL0002透明漆 二塗二烤			HLMBC600B內箱
8280-041	導桿	2PCS	
			
23MBC800B	附件包	1SET	HLMBC600B內箱
23MDCUP	附件包-CUP	1SET	HLMBC600B內箱
25MBC600	皮帶輪包	1SET	HLMBC600B內箱
GMBC600B	螺絲包	1SET	HLMBC600B內箱

零件代碼	品名及圖案	用量	備註
8331-058	固定片	1SET	1. 組立M6X12L=1PCS 半圓頭內六角螺絲 2. 組立M6-Ø13=1PCS
國麗3124S-閃銀			HLMBC600B內箱
8311-164	固定片	1SET	
國麗3124S-閃銀			HLMBC600B內箱
			

零件代碼	品名及圖案	用量	備註
9121-084	座墊 黑色耐寒乳膠皮	1SET	

零件代碼	品名及圖案	用量	備註
9121-084R	座墊 紅色耐寒乳膠皮	1SET	

零件代碼	品名及圖案	用量	備註
9131-039	座墊 黑色耐寒乳膠皮	1SET	

零件代碼	品名及圖案	用量	備註
9131-039R	座墊 紅色耐寒乳膠皮	1SET	

# MBC600 ASSEMBLY INSTRUCTIONS

## FARME HARDWARE ILLUSTRATION

DD1. Ø3/4" SHAFT COLLAR(9211-147).....[2PCS]  
 DD2. Ø4" RUBBER DOUNT(9310-017).....[2PCS]  
 DD3. 108X14.5X263L RUBBER PAD(9310-075).....[2PCS]  
 DD4. Ø115X50L PULLEY-NO MAGNET(9213-042B).....[3PCS]

DD6. BOTTLE BRACKET(8388-025).....[1PCS]  
 DD7. BOTTLE RACK(9260-320).....[1PCS]  
 DD8. BOTTLE(9260-123).....[1PCS]  
 DD11. TOP PLATE(8400-033).....[1PCS]  
 DD12. Ø3/4" SHAFT COLLAR(9211-167).....[2PCS]  
 DD13. WEIGHT SELECTOR BAR(8210-216C).....[1PCS]

DD1.



DD2.



DD3.



DD4.

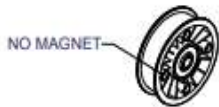

DD6.



DD7.



DD8.



DD11.



DD12.



DD13.



# MBC600 ASSEMBLY INSTRUCTIONS

## HARDWARE ILLUSTRATION

D1. Ø60 CAP COVER(8130-231).....[1PCS]  
 D2. Ø10X60L SHAFT(8210-156).....[1PCS]  
 D3. THRUST BEARING(8510-008).....[1PCS]  
 D4. Ø38X26X1.5t CU WASHER(8520-008).....[2PCS]  
 D5. Ø50 END CAP(9211-020).....[1PCS]  
 D6. 108X15tX263L RUBBER PAD(9310-075).....[1PCS]  
 D7. 3590mm BELT (FMBC6001).....[1PCS]  
 D8. Ø50XØ26X3t NYLON WASHER(9214-001).....[1PCS]

D1.



D2.



D3.



D4.



D5.



D6.



D7.

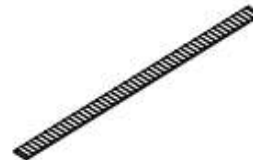

D8.



# MBC600 ASSEMBLY INSTRUCTIONS

## PARTS ILLUSTRATION SHEET

A [1SET]  
6621-003



B [1SET]  
6630-005

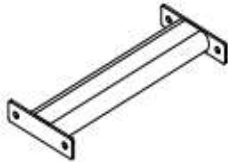

C [1SET]  
6630-004

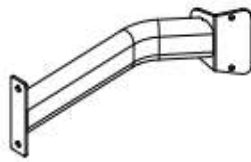

D [1SET]  
6680-017

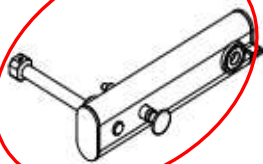

E [1SET]  
6680-016



F [1SET]

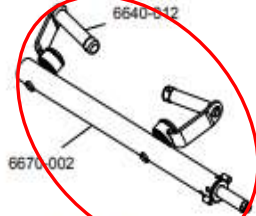

G [1PCS]  
8313-144



H [1PCS]  
8311-117



I [1PCS]  
9420-102



J [1PCS]  
9121-084



K [1PCS]  
9131-039



# MBC600 ASSEMBLY INSTRUCTIONS

## FARME PARTS ILLUSTRATION SHEET

AA1 [1SET]  
6610-015

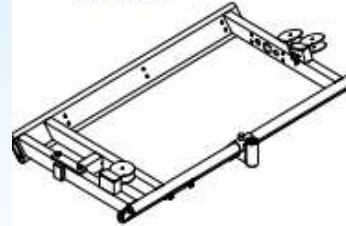

AC1 [1PCS]  
9220-020

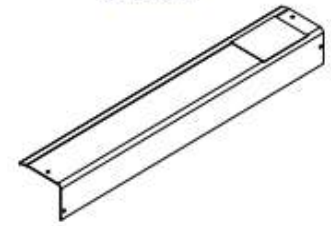

AD [1PCS]  
9220-019

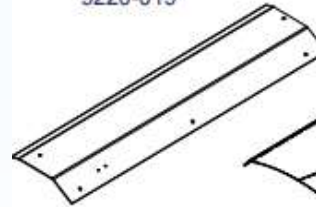

AE [1SET]  
9220-023

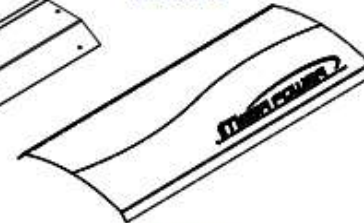

AF [1SET]  
9211-148



AG [4SET]  
8331-057



AH [1SET]  
8313-169



AJ1 [2PCS]  
8280-041  
Ø3/4"X1243L



AK [1PCS]  
8331-056



AL [3SET]  
8331-058



# MBC600 ASSEMBLY INSTRUCTIONS

## FARME PARTS ILLUSTRATION SHEET

AM [2PCS]  
8313-144



AP [1PCS]  
8311-117

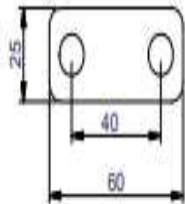

AR [1PCS]  
8311-194

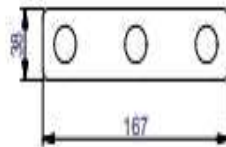
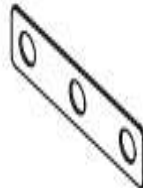

# MBC600 ASSEMBLY INSTRUCTIONS

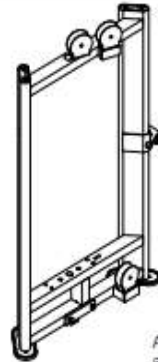

Above shows STEP 1  
assembled and completed

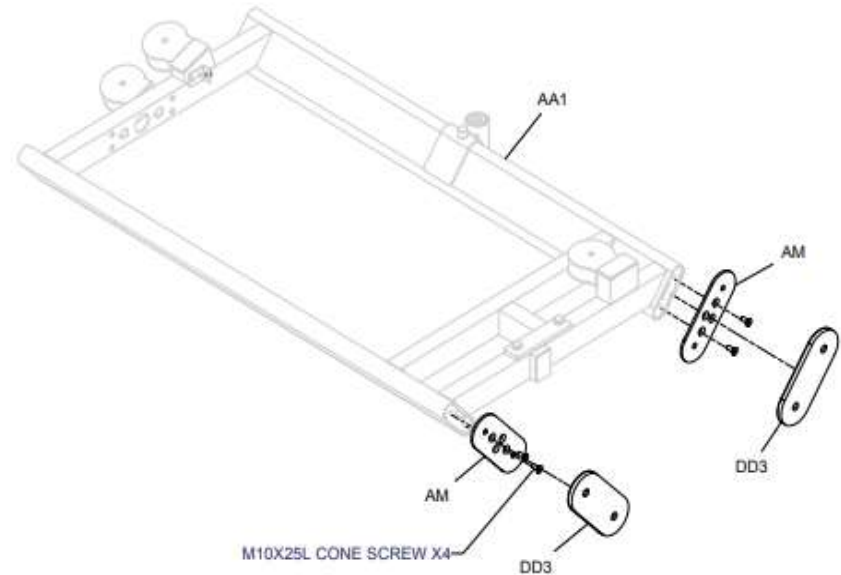

## MBC600 ASSEMBLY INSTRUCTIONS

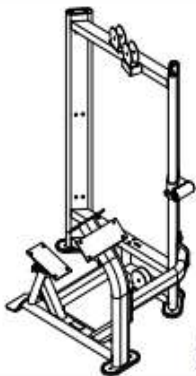

Above shows STEP 2 assembled and completed

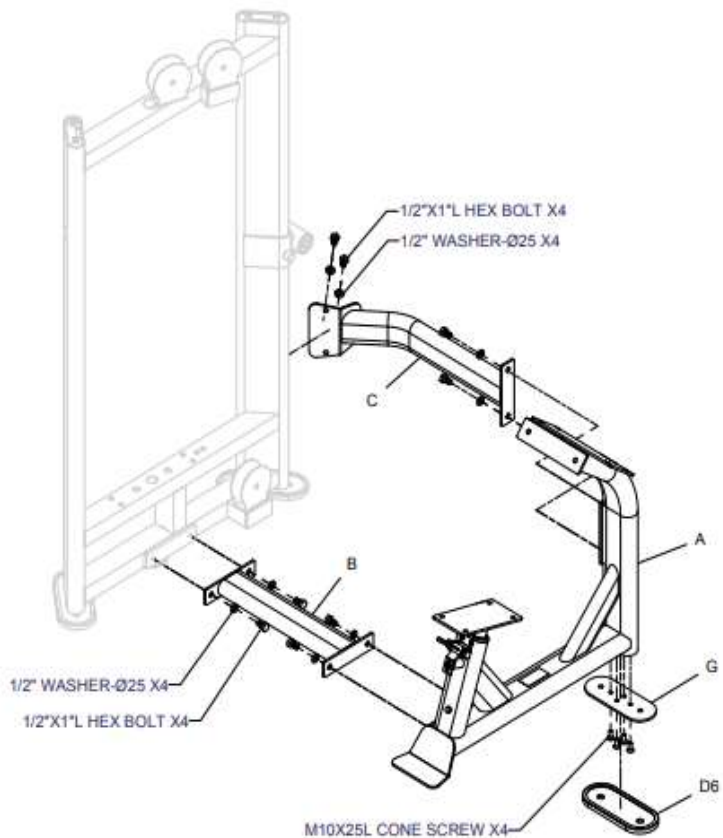

## MBC600 ASSEMBLY INSTRUCTIONS

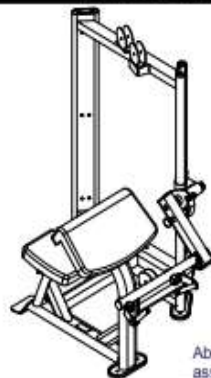

Above shows STEP 3 assembled and completed

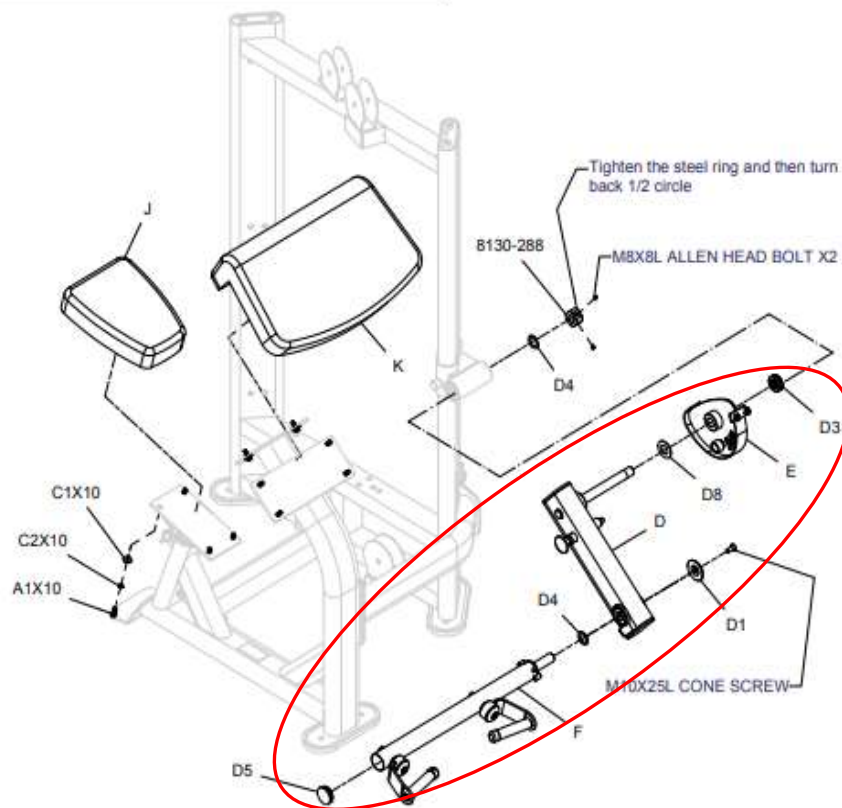

# MBC600 ASSEMBLY INSTRUCTIONS

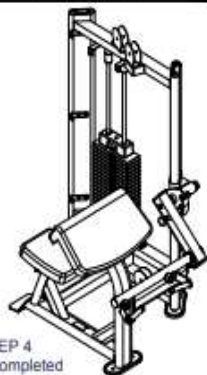

Above shows STEP 4 assembled and completed

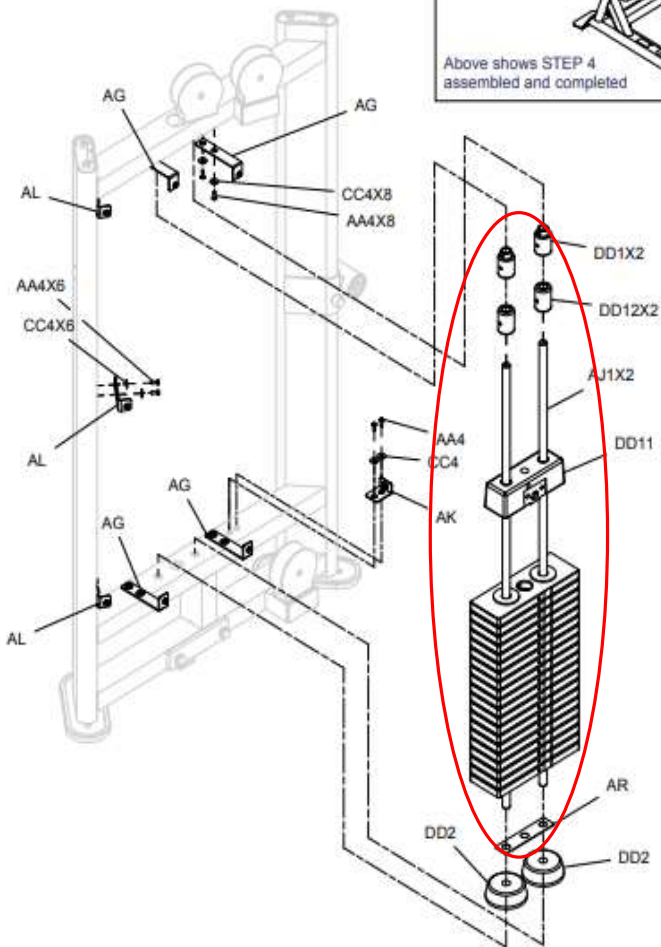

# MBC600 ASSEMBLY INSTRUCTIONS

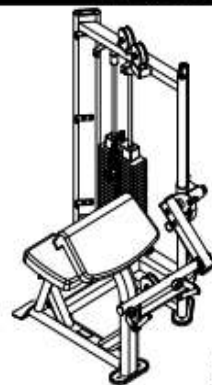

Above shows STEP 5 assembled and completed

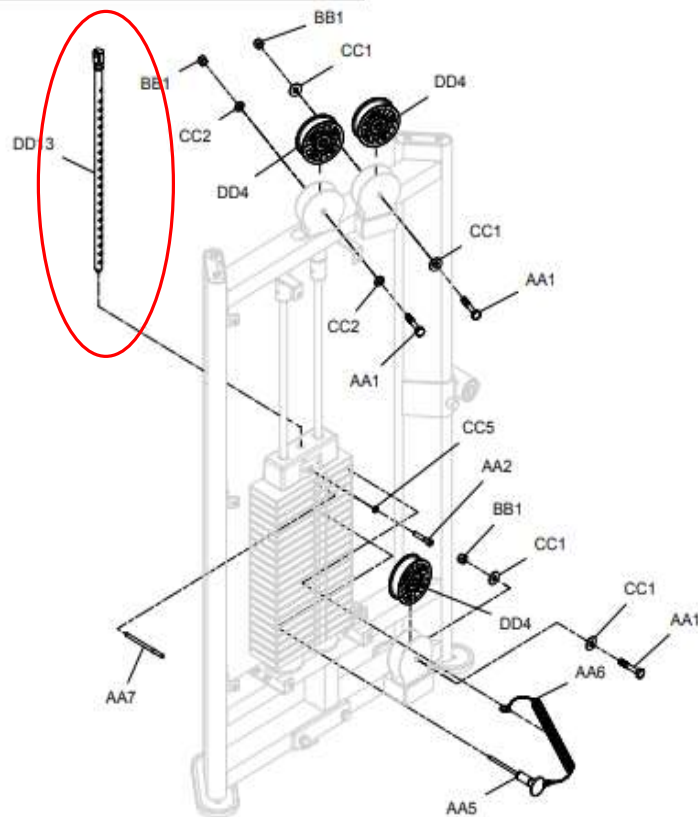

# MBC600 ASSEMBLY INSTRUCTIONS

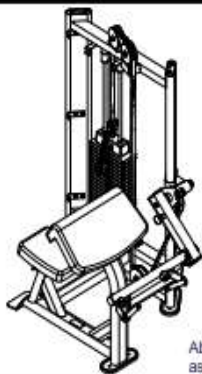

Above shows STEP 6 assembled and completed

The tread side should be outward

M10X25L ROUND BOLT X2

M10 SPRING WASHER X2

M10X25L ROUND BOLT X2  
M10 SPRING WASHER X2

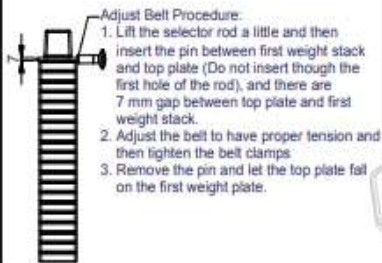
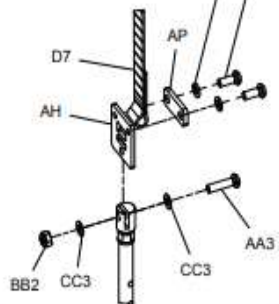

**Adjust Belt Procedure:**

1. Lift the selector rod a little and then insert the pin between first weight stack and top plate (Do not insert through the first hole of the rod), and there are 7 mm gap between top plate and first weight stack.
2. Adjust the belt to have proper tension and then tighten the belt clamps
3. Remove the pin and let the top plate fall on the first weight plate.

The belt should reserve 40mm extra length



# MBC600 ASSEMBLY INSTRUCTIONS

Post location

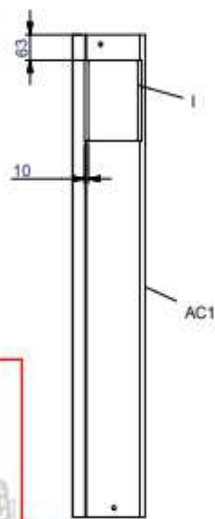

Above shows STEP 7 assembled and completed

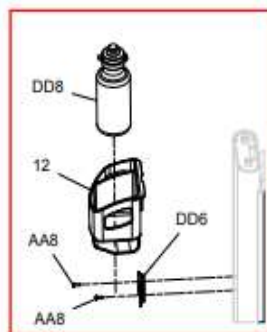
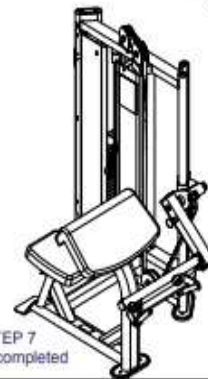

DD8

12

AA8

AA8



AD

AC1

M6X12L ROUND BOLT X5

M6 WASHER Ø14 X5

M6 WASHER Ø14 X4

M6X12L ROUND BOLT X4

## MBC600 ASSEMBLY INSTRUCTIONS

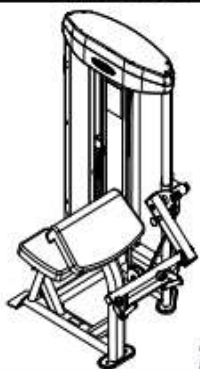

Above shows STEP 8 assembled and completed

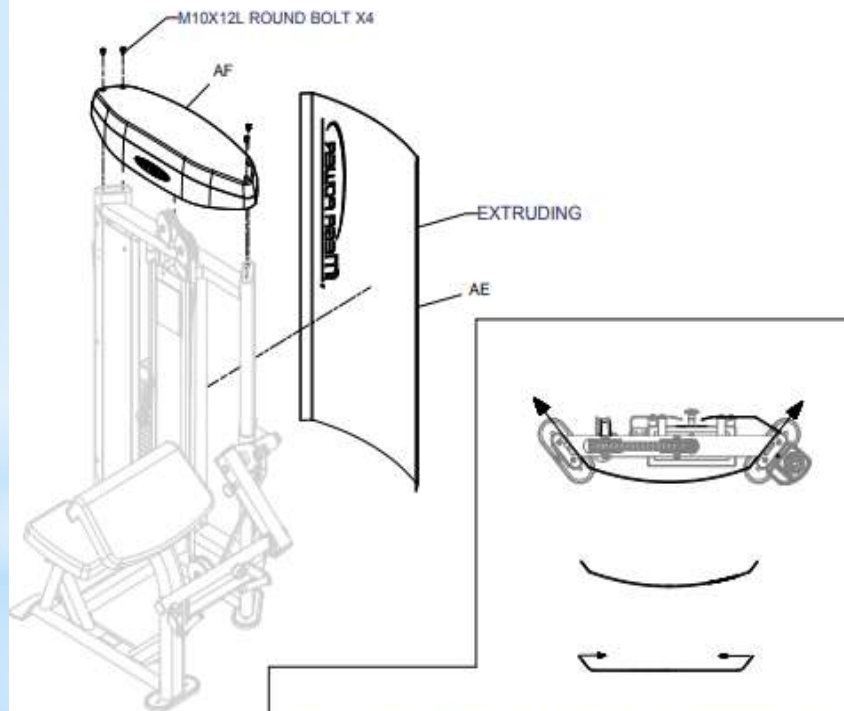

Note: When installing the shroud (AE), push both sides of the shroud toward center in order to bend it a little.  
After insert it to the door frame and then releasing it. The shroud will be locked on the door frame.

## ASSEMBLY INSTRUCTIONS

### Adjust Flat Belt Steps

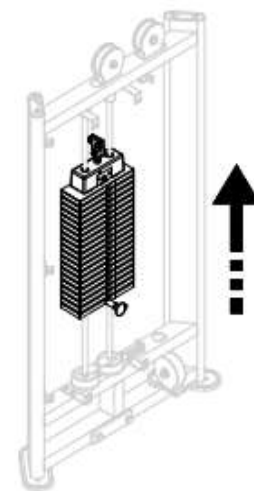
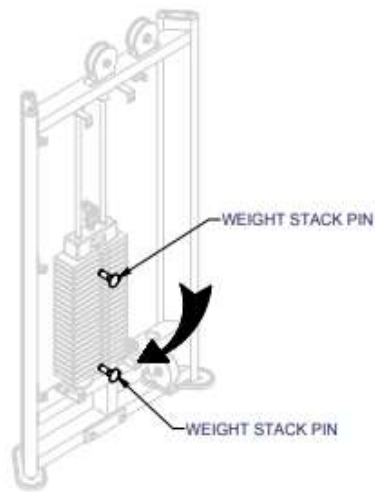

1. When installing flat belt, please put the weight stack pin into 4<sup>th</sup> weight stack. After installing flat belt, please put the weight stack pin into 20<sup>th</sup> weight stack.

2. When weight stack pin put into 20<sup>th</sup> weight stack, please do workout with the machine around 1 minute or 5-10 sets in order to extend the flat belt, flat belt will be loosed a little bit.

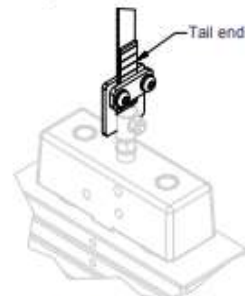

3. Pull end of flat belt as drawing showed to make the flat belt be tightened.  
(After using the machine 3 months to 6 months, please check flat belt. If the flat belt is loosed, please follow this step to tighten the belt again.)

## Guide on Selector Rod Adjustment

### STEP 1

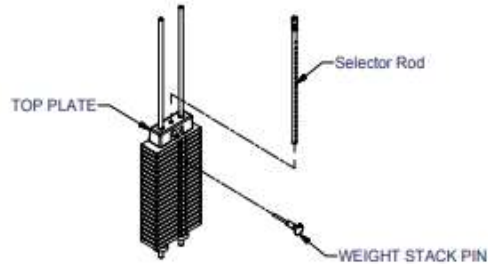

Step 1  
Place Selector Rod into Top Plate.  
Then put selector pin into the weight plate to fix the rod.

### STEP 2

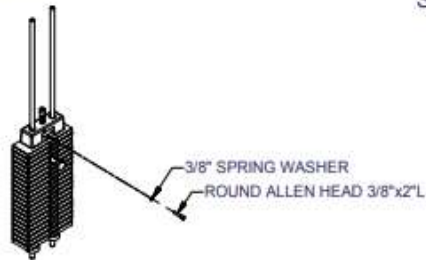

Step 2  
Screw the 3/8"x2"L Round Allen Head  
into Top Plate but not tighten it up.

### STEP 3

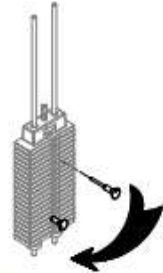

Step 3  
Place the selector pin to each weight plate  
(5,10,15,20....) to check the smoothness.

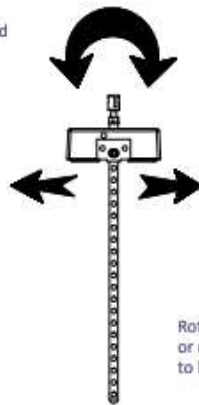

Rotate the Selector Rod slightly  
or move the 3/8"x2"L Round Allen Head  
to left and right and repeat Step 3.

## MEGA POWER series JUNGLE GYM series

project	Part number	Name	Specification	Quantity	Remark
1	38-200 CAP	round allen head	3/8"x2"L round allen head-CAP	1	
2	38-SPWAS 8732003	3/8" spring washer		1	
3	8210-216C	20 hole Selector Rod		1	
4	8250-166	pin	Ø7.9X137L	1	
5	8250-162	weight stack pin	Ø7X110L	1	
6	8400-010	10LB weight stack plate	102.22x280L 10LB	20	
7	8400-033	top plate		1	

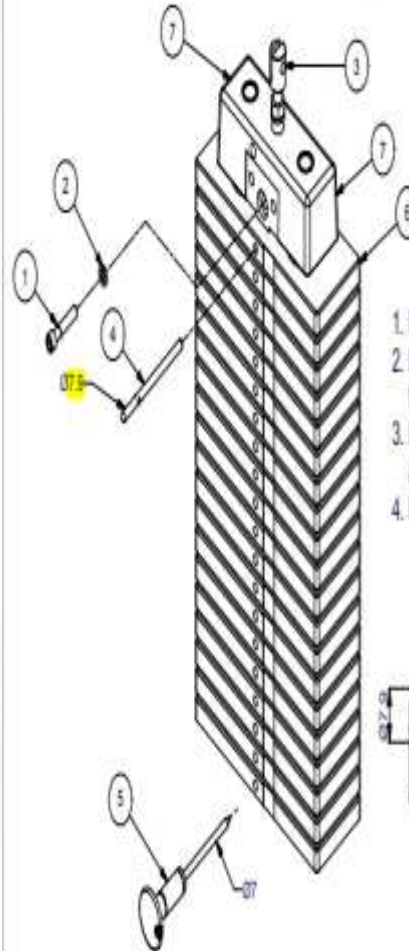

1. Place #4 - 8250-166 (pin) into the first weight plate.
2. Place #5 - 8250-162 (weight stack pin) into the hole 20th of the weight stack.
3. Make sure #7 (top plate) cling to #6 (first weight plate) and fix in #1 - 3/8"x2"L screw and #2 - 3/8" spring washer.
4. Finally remove #5 - 8250-162 (weight stack pin) and use as usual.

\*Well done!

