

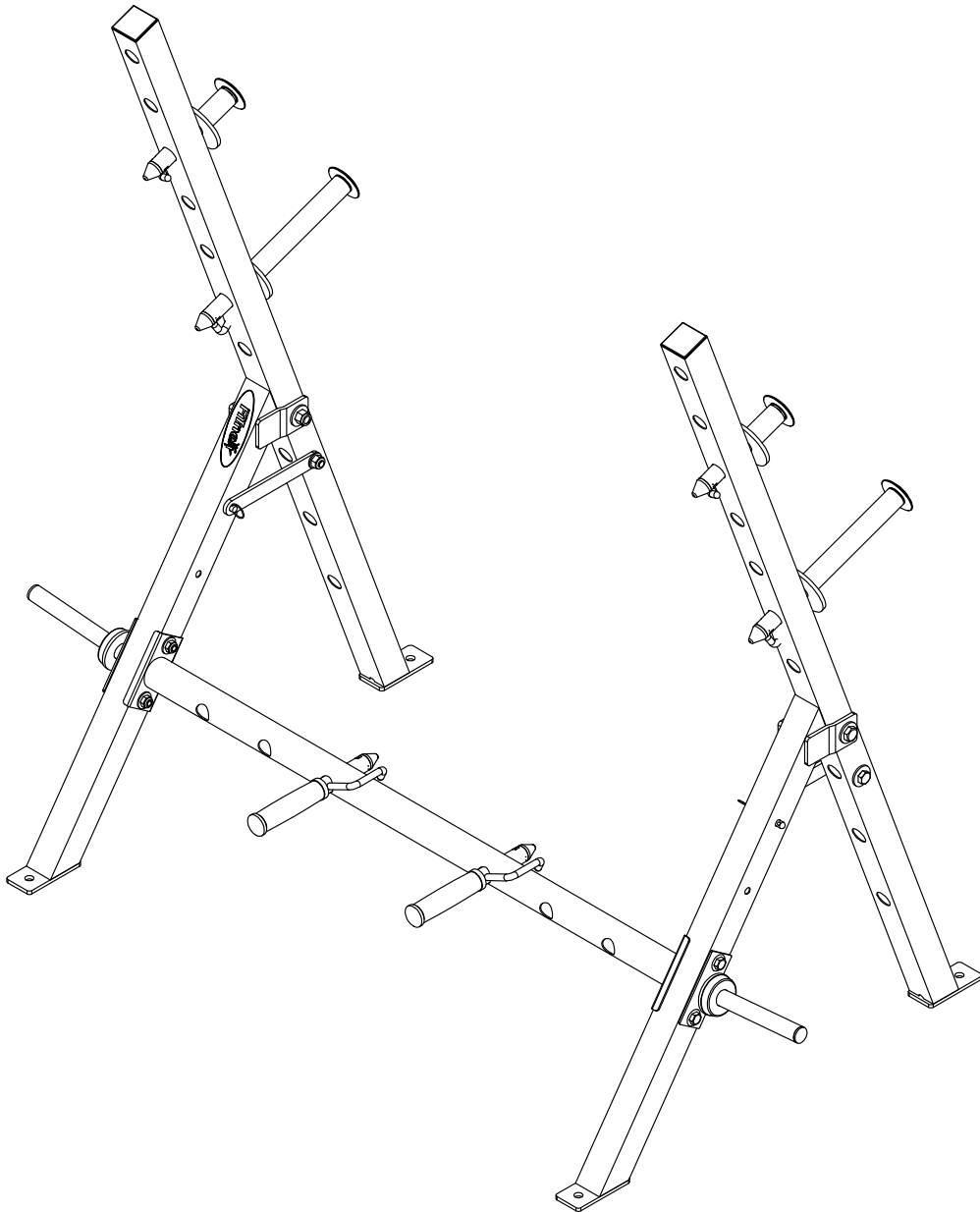

RPR



Assembly & Instructions
OWNER'S & MANUAL

RPR HARDWARE
(shown in actual size)

A1.M12X85 General External Hexagon Screws Qty.2

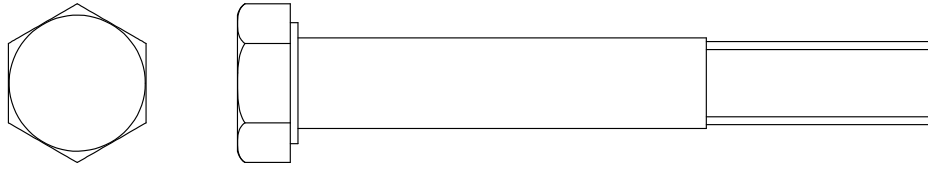

A2.M10X25 HEX Screw, Tapered Qty.4(Pre-installed)



A3.M10X70L General External Hexagon Screws Qty.4

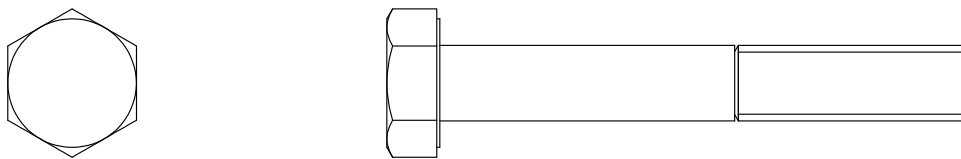

A4.M12X75L General External Hexagon Screws Qty.2

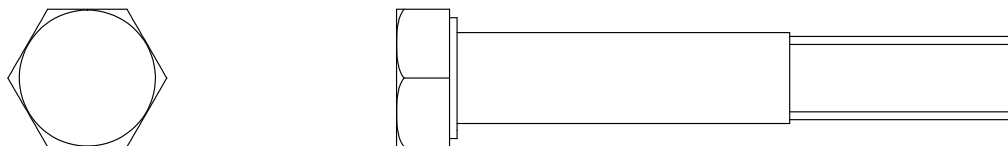

C2.M10 WASHER (Ø27) Qty.8

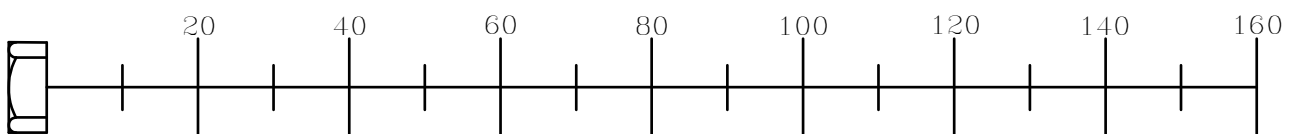
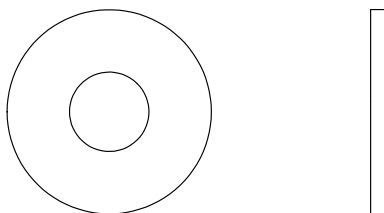

RPR HARDWARE
(shown in actual size)

C3.M12 WASHER (Ø25) Qty.2

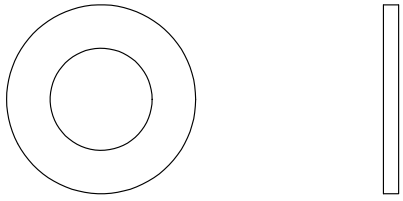

C4.M12 WASHER (Ø34) Qty.6

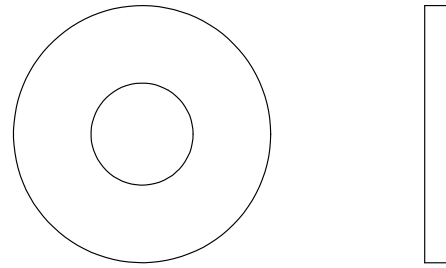

B2.M10 NYLON LOCK NUT Qty.4

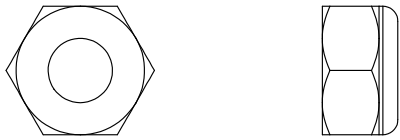

B3.M12 NYLON LOCK NUT Qty.4

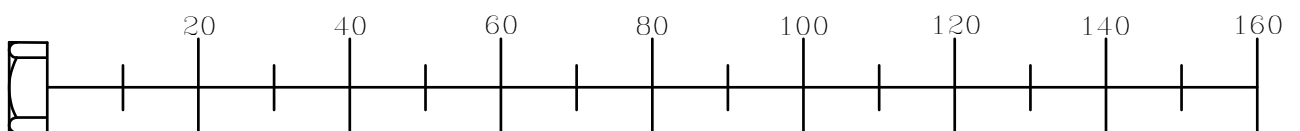
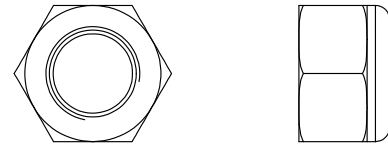

RPR HARDWARE
(shown in actual size)

A[2PCS]

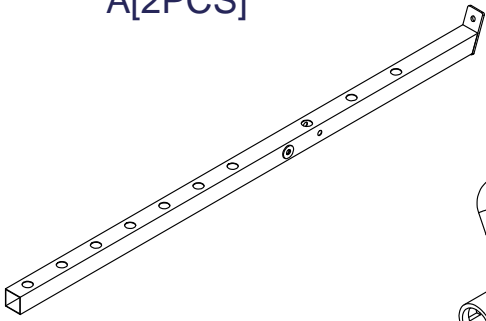

B[2PCS]

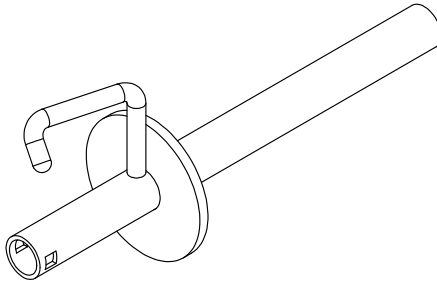

C[2PCS]

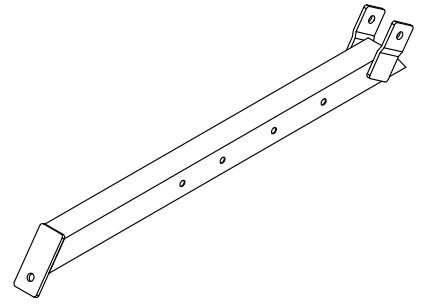

F[2PCS]

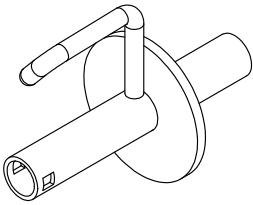

J[1PCS]

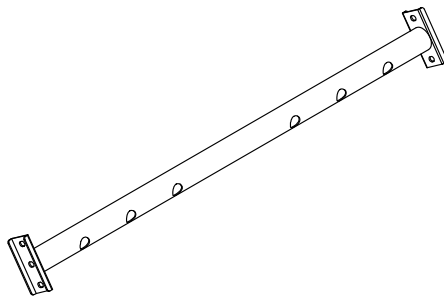

K[1PCS]

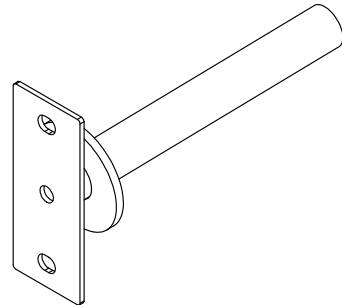

K[1PCS]

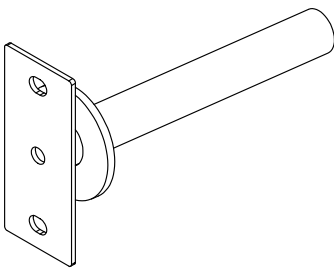

M[2PCS]

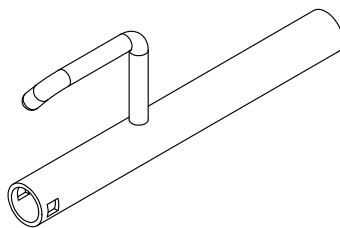

G[2PCS]
(8341-066)

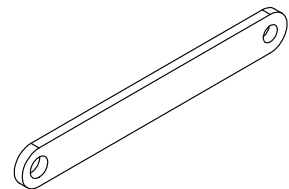

RPR HARDWARE
(shown in actual size)

D2.Fonseca(9211-225).....	[2PCS]
D3.Double Bead Bolt(8250-015).....	[2PCS]
D4.Pipe Plug(9211-016).....	[2PCS]
D5.Rubber Ring(9310-011).....	[2PCS]
D6.Tapered Plug(9211-045)(Pre-installed).....	[6PCS]
D5.Sheathing(9212-085)(Pre-installed).....	[2PCS]
D5.End Cap(8130-248)(Pre-installed).....	[4PCS]
D5.Sheathing(9212-086)(Pre-installed).....	[2PCS]
D5.Bone Type Handle(9212-016)(Pre-installed).....	[2PCS]

D2

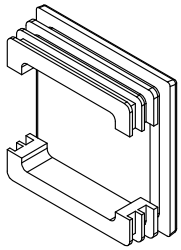

D3

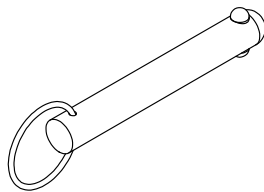

D4

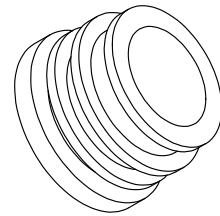

D5

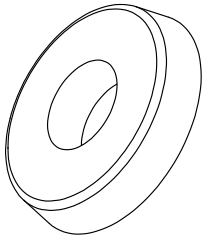

D6

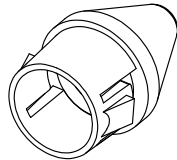

D7

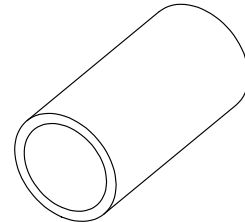

D8

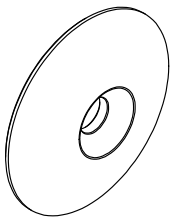

D9

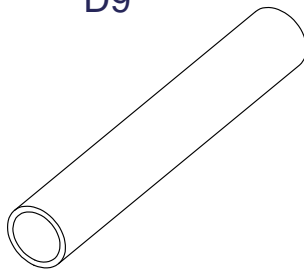

D10

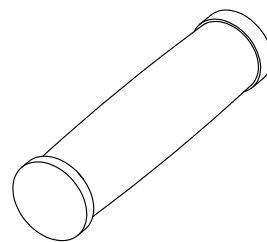

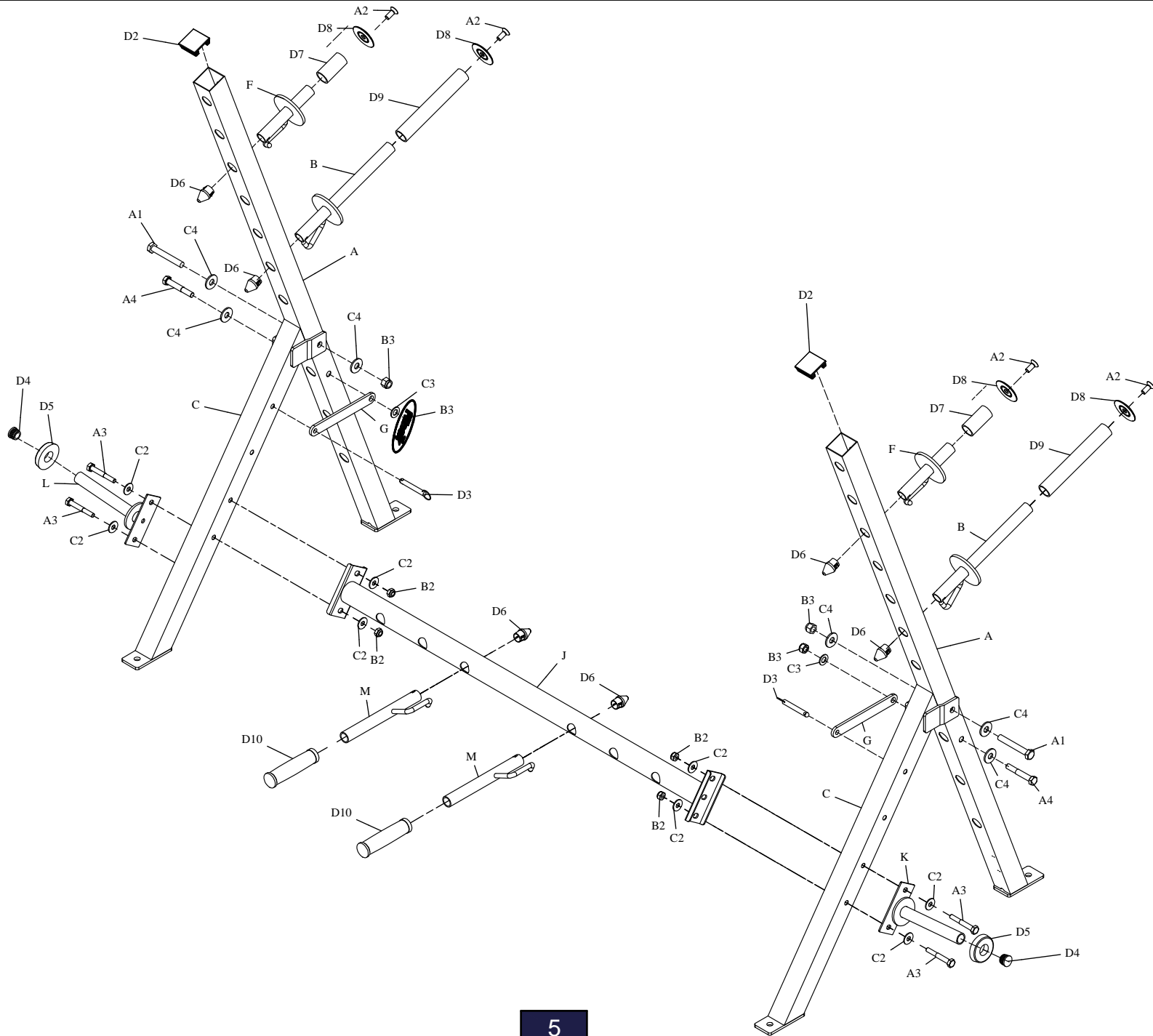

THERE IS A RISK ASSUMED BY INDIVIDUALS WHO USE THIS TYPE OF EQUIPMENT. TO MINIMIZE RISK, YOU MUST FOLLOW THESE RULES:

1. Inspect equipment before each workout. Check that all nuts, bolts, screws and pop pins are in place and fully tightened. Also, before use, check cables for signs of wear. Replace all worn parts immediately. Never use machine if any parts are damaged or missing. Failure to follow these rules may result in serious injury.
2. Keep clear of the cables and all moving parts when the machine is in use.
3. Always make sure all Snap Links are closed when doing any cable/pulley exercises.
4. Exercise with care. Perform your exercises at a smooth moderate pace; never perform jerky or uncoordinated movements that may cause injury.
5. It is recommended that you should workout with a training partner.
6. Do not allow children or minors to play on or around this equipment.
7. If unsure of proper use of equipment, call your local distributor Steelflex or Fitnex distributor.
8. **WARNING:** Consult your physician before starting your exercise program. For your own safety, do not begin any exercise program without proper instruction.



10-1 WARRANTY

PLEASE CONSULT YOUR PHYSICIAN BEFORE USING THIS PRODUCT.

This Warranty applies products manufactured or distributed by Joong Chenn Industry Co., Ltd under the FITNEX brand name. The warranty period to the original purchaser is 3 years on frame and 1 year on ALL parts.

FITNEX warrants that the Product you have purchased for non-commercial, personal, family, or household use from FITNEX or from an authorized FITNEX reseller is free from defects in materials or workmanship under normal use during the warranty period. Your sales receipt, showing the date of purchase of the Product, is your proof of the date of purchase. This warranty extends only to you, the original purchaser. It is not transferable to anyone who subsequently purchases the Product from you. It excludes expendable parts such as paint and finish. This Warranty becomes VALID ONLY if the Product is assembled / installed according to the instructions / directions included with the Product.

During the warranty period FITNEX will at no additional charge, repair or replace (at FITNEX option) the Product if it becomes defective, malfunctions, or otherwise fails to conform with this Warranty under normal non-commercial, personal, family, or household use. In repairing the product FITNEX may replace defective parts or, at the option of FITNEX, serviceable used parts that are equivalent to new parts in performance. All exchanged parts and Products replaced under this warranty will become the property of FITNEX. FITNEX reserves the right to change manufacturers of any part to cover any existing warranty.

To obtain warranty service, you must return the Product to FITNEX in its original container (or equivalent). You must pre-pay any shipping charges, export taxes, customs duties and taxes, or any other charges associated with transportation of the Product.

In addition, you are responsible for insuring any Product shipped or returned. You assume the risk of loss during shipment. You must present FITNEX with proof-of-purchase documents (including the date of purchase). Any evidence of alteration, erasing or forgery of proof-of-purchase documents will be cause to void this Warranty.

This Warranty does not extend to any Product not purchased from FITNEX or from an authorized FITNEX reseller. This Warranty does not extend to any Product that has been damaged or rendered defective; (a) as a result of accident, misuse, or abuse; (b) by the use of parts not manufactured or sold by FITNEX; (c) by modification of the Product; (d) as a result of service by anyone other than FITNEX, or an authorized FITNEX warranty service provider. Should any product submitted for Warranty service be found to be ineligible, an estimate of repair cost will be furnished and the repair will be made if requested by you upon FITNEX receipt of payment or acceptable arrangement of payment.

EXCEPT AS EXPRESSLY SET FORTH IN THIS WARRANTY FITNEX MAKES NO OTHER WARRANTIES, EXPRESSED OR IMPLIED INCLUDING ANY IMPLIED WARRANTIES OF MERCHANTABILITY AND FITNESS FOR A PARTICULAR PURPOSE. FITNEX EXPRESSLY DISCLAIMS ALL WARRANTIES NOT STATED IN THIS WARRANTY. ANY IMPLIED WARRANTIES THAT MAY BE IMPOSED BY LAW ARE LIMITED TO THE TERMS OF THIS WARRANTY. NEITHER FITNEX NOR ANY OF ITS AFFILIATES SHALL BE RESPONSIBLE FOR INCIDENTAL OR CONSEQUENTIAL DAMAGES. SOME STATES OR COUNTRIES DO NOT ALLOW LIMITATIONS ON HOW LONG AN IMPLIED WARRANTY LASTS OR THE EXCLUSION OR LIMITATION OF INCIDENTAL OR CONSEQUENTIAL DAMAGES, SO THE ABOVE LIMITATIONS OR EXCLUSION MAY NOT APPLY TO YOU. This Warranty gives you specific legal rights and you may also have other rights that may vary from country to country. This is the only express warranty applicable to FITNEX branded products. FITNEX neither assumes nor authorizes anyone to assume for it any other express warranty.

If you have any questions regarding the warranty, please kindly contact your local authorized FITNEX reseller or email to joong@ms13.hinet.net

Keep this card with a copy of your **original bill of sale**. This will help process warranty claims if necessary.

PLEASE READ CAREFULLY FOR YOUR REFERENCE

Keep this card with a copy of your **original bill of sale**. This will help process warranty claims if necessary.



WARRANTY REGISTRATION

PLEASE FILL OUT AND KEEP THIS WARRANTY CARDS FOR YOUR RECORDS

Congratulations! You have just purchased a quality FITNEX product. To validate the FITNEX Warranty, please have the purchaser complete the following information and keep this warranty card and a copy of your purchase receipt for your records.

SERIAL NO. _____ **(required)**

NAME OF PURCHASER _____

ADDRESS _____

CITY _____ STATE _____ ZIP _____

PHONE _____

EMAIL _____ FAX _____

The undersigned hereby acknowledges receipt of the FITNEX Warranty and affirms that the date of purchase was _____, 20_____. I have read and understand the conditions and terms of the FITNEX Warranty in its entirety.

STORE PURCHASED FROM _____

CITY _____ STATE _____ ZIP _____

MODEL _____ PRICE _____

DATE OF INSTALLATION _____

SIGNATURE _____

1. Where did you purchase this product from?

2. Who will use this product?
_____% Male _____% Female

3. Your Age Group:
____ Under 25 _____ 55-64
____ 25-34 _____ 65-74
____ 35-44 _____ 75-84
____ 45-54

4. What group best represents your family income?
____ less than \$50,000 _____ \$100,000 - \$149,999
____ \$50,000 - \$74,999 _____ over \$150,000
____ \$75,000 - \$99,999

5. How did you first learn about this product?
____ Magazine _____ Dealer
____ Newspaper Ad _____ Yellow Pages
____ Mail Order Catalog _____ Fitness Factory Web site
____ Radio or TV Ad _____ Other Web site
____ Friend or Relative _____ Other

6. Why did you purchase our product?
____ Design / Appearance
____ Dealer Recommendation
____ Price
____ Ease of Operation
____ Quality Construction
____ Price/Value
____ Reputation
____ Warranty
____ Friend / Family Recommendation
____ Other _____

CAUTION - PLEASE NOTE - WARNING

THERE IS A RISK ASSUMED BY INDIVIDUALS WHO USE THIS TYPE OF EQUIPMENT. TO MINIMIZE RISK, YOU MUST FOLLOW THESE RULES:

1. Inspect equipment before each workout. Check that all nuts, bolts, screws and pop pins are in place and fully tightened. Also, before use, check cables for signs of wear. Replace all worn parts immediately. NEVER use machine if any parts are damaged or missing. Failure to follow these rules may result in serious injury.
2. Keep clear of the cables and all moving parts when the machine is in use.
3. Always make sure all Snap Links are closed when doing any cable / pulley exercises.
4. Exercise with care. Perform your exercises at a smooth moderate pace; never perform jerky or uncoordinated movements that may cause injury.
5. It is recommended that you should workout with a training partner.
6. Do not allow children or minors to play on or around this equipment.
7. If unsure of proper use of equipment, call your local FITNEX distributor.
8. WARNING: Consult your physician before starting your exercise program. For your own safety, do not begin any exercise program without proper instruction.



WARRANTY Registration Card

See Details On Back.
You must complete and keep this warranty card and
a copy of your purchase receipt for this
Warranty to be Valid

This will help process warranty claims if necessary.

Serial Number _____



IF YOU HAVE ANY QUESTIONS REGARDING YOUR WARRANTY,
PLEASE KINDLY CONTACT YOUR LOCAL AUTHORIZED FITNEX RESELLER
OR EMAIL TO joong@ms13.hinet.net

IMPORTANT!

Warranty Registration Card