

Body-Solid

THERE IS A RISK ASSUMED BY INDIVIDUALS WHO USE THIS TYPE OF EQUIPMENT. TO MINIMIZE RISK, YOU MUST FOLLOW RULES :

1. Inspect equipment before each workout. Check that all nuts, bolt, screws and pop pins are in place and fully tightened. Also, before use, check cables for signs of wear. Replace all worn parts immediately. Never use machine if any parts are damaged or missing. Failure to follow these rules may result in serious injury.
2. Keep clear of the cable and all moving parts when machine is in use.
3. Always make sure all Snap Links are closed when doing any cable/pulley exercises.
4. Exercise with care. Perform your exercise at a smooth moderate pace; never perform jerky or uncoordinated movement that may cause injury.
5. It is recommended that you should workout with a training partner.
6. Do not allow children or minors to play on or around this equipment.
7. If unsure of proper use of equipment, call your local Body-Solid distributor or the Body-Solid customer service department at 1-800-556-3113.
8. **WARNING :** Consult your physician before starting your exercise program. For your own safety, do not begin any exercise program without proper instruction.

RAL2-11-98

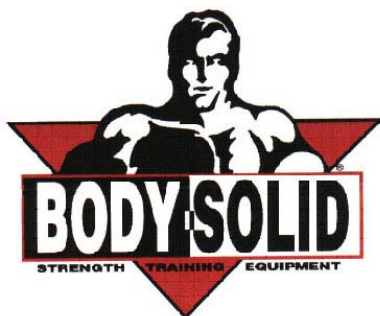
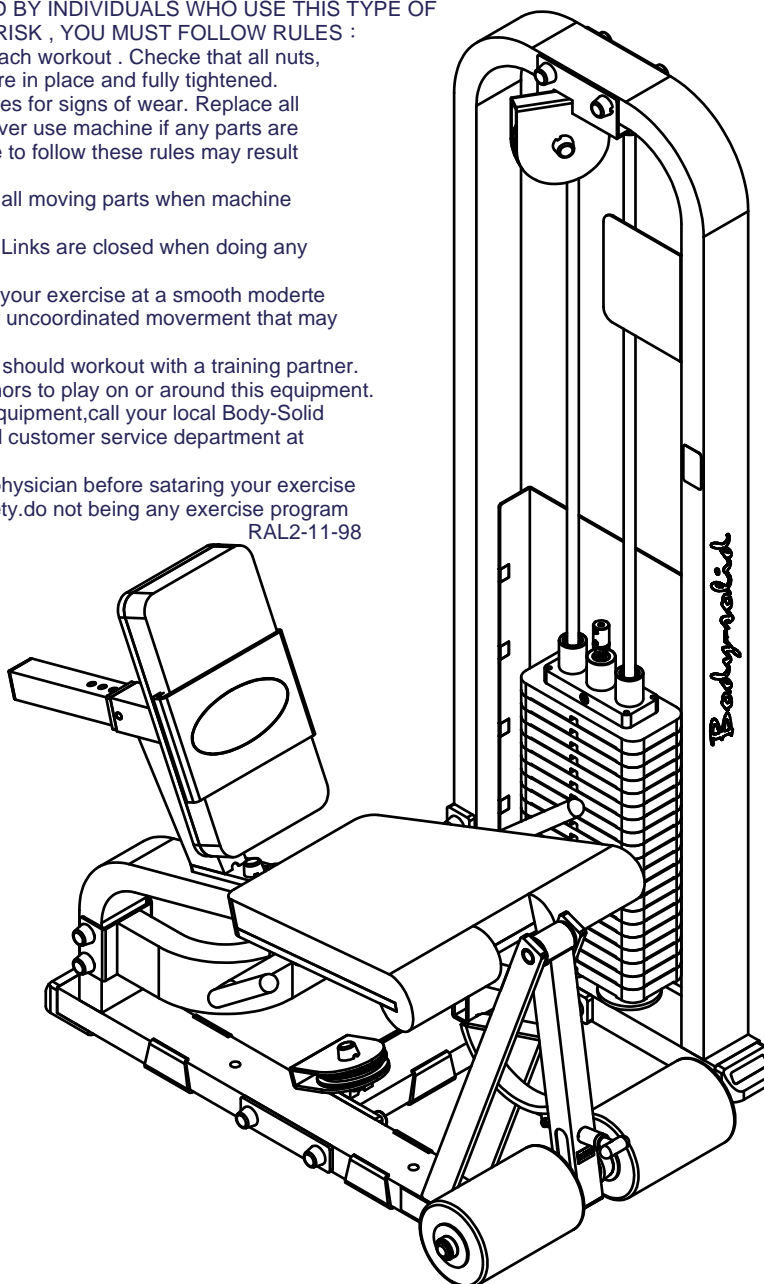

BODY-SOLID, Inc.
1900 S. Des Plaines Ave.
Forest Park, IL 60130 USA
Phone: (708) 427-3555
Fax: (708) 427-3556
www.bodysolid.com

SLE-200.3 OWNER'S MANUAL

SLE-200 ASSEMBLY INSTRUCTIONS

HARDWARE ILLUSTRATION

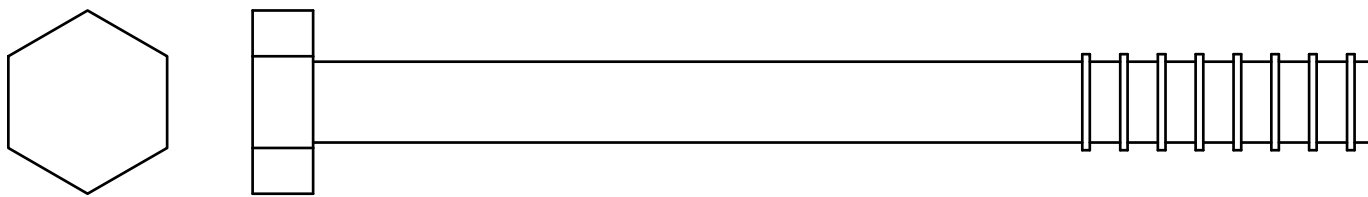

(A1)HEX BOLT 1/2"X5-1/2"L PARTIAL QTY.6

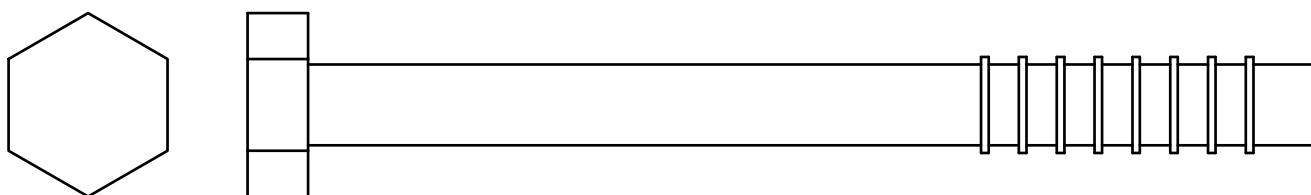

(A2)HEX BOLT 1/2"X5-1/4"L PARTIAL QTY.1

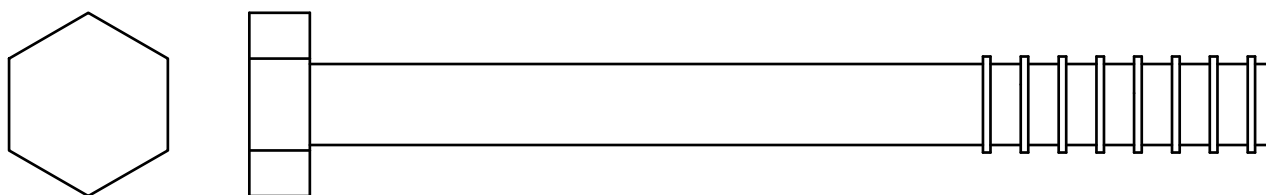

(A3)HEX BOLT 1/2"X5"L PARTIAL QTY.4

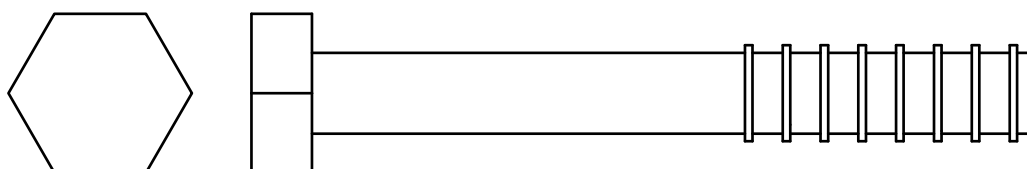

(A4)HEX BOLT 1/2"X3-3/4"L PARTIAL QTY.2

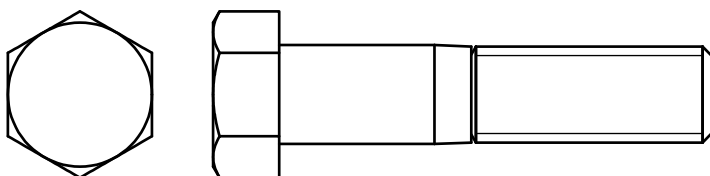

(A5)HEX BOLT 1/2"X2-1/4"L PARTIAL QTY.3

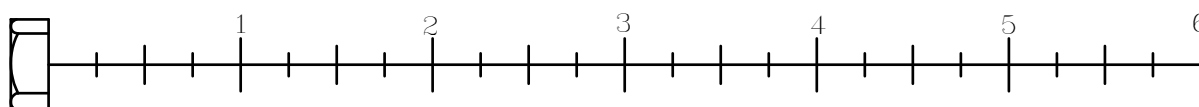

SLE-200 ASSEMBLY INSTRUCTIONS

HARDWARE ILLUSTRATION

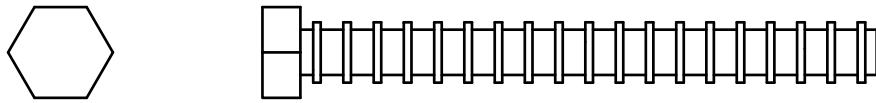

(A6)HEX BOLT 5/16"X3L" PARTIAL QTY.1

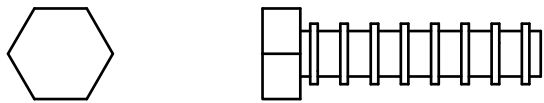

(A7)HEX BOLT 5/16"X1-1/4L" PARTIAL QTY.6

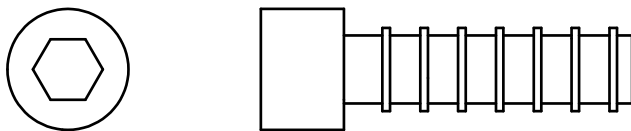

(A8)ROUND INNER HEAD 7/16"X1-1/2" PARTIAL QTY.1

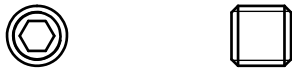

(A9)ALLEN SCREW 5/16"X3/8L" PARTIAL QTY.3

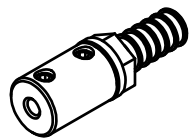

(A10)WEIGHT STACK CABLE (8260-010) QTY.1

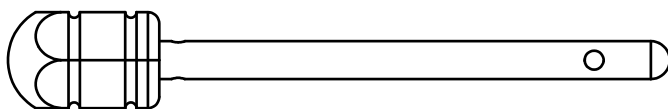

(A11)10LB PIN (8250-022) QTY.1

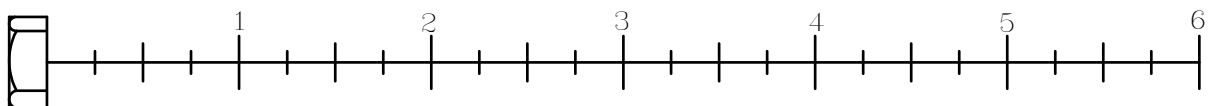

SLE-200 ASSEMBLY INSTRUCTIONS

HARDWARE ILLUSTRATION

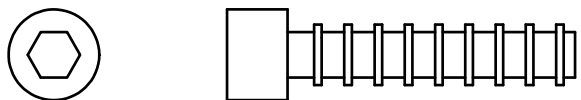

(A12)ROUND INNER HEAD 5/16"X1-1/2" PARTIAL QTY.1



(A13)STEEL BUSHING Ø1/2"XØ8.5X21L QTY.1

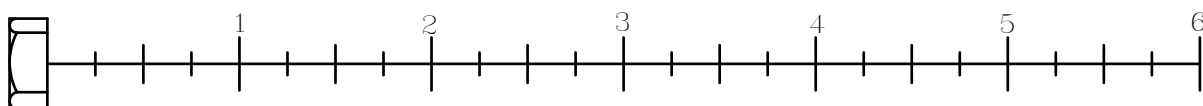

SLE-200 ASSEMBLY INSTRUCTIONS

HARDWARE ILLUSTRATION

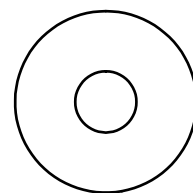
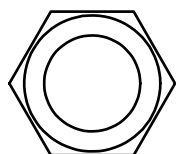
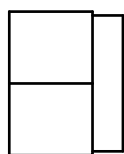

(B1) NYLON LOCK NUT 1/2" QTY.16 (C3) 5/16" (I.D.) WASHER Ø24 QTY.7

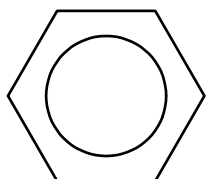

(B2) LOCK NUT 5/8" QTY.1

(C4) 5/16" SPRING WASHER QTY.7

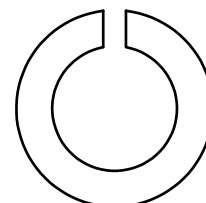
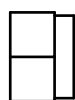

(B3) NYLON LOCK NUT 5/16" QTY.1

(C5) 5/8" SPRING WASHER QTY.1

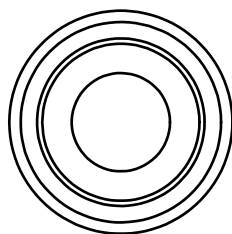

(C1) ROUND END CAP WASHER QTY.32

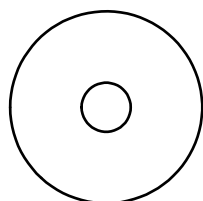

(C2) Ø1" CHROME WASHER QTY.2

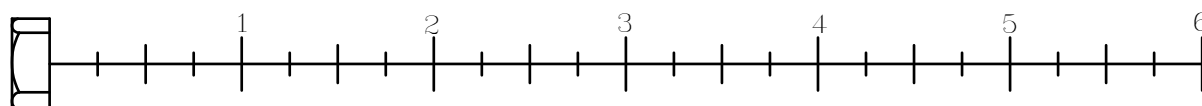

SLE-200 ASSEMBLY INSTRUCTIONS

HARDWARE ILLUSTRATION

D1.



D1. 1.5" BOLE CAP(9212-024) -----[32PCS]

D2. 2"X4" FOOT END CAP(9211-028) -----[4PCS]

D3. 2"X2"X1.8t END CAP(9211-005) -----[2PCS]

D5. Ø2" NYLON WASHER(9214-001) -----[2PCS]

D6. Ø4" RUBBER DONUT(9310-017) -----[2PCS]

D7. Ø6" PULLEY(9213-009)-----[1PCS]

D2.

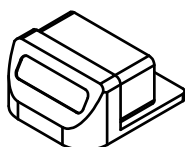

D8. Ø4-1/2" PULLEY(9213-010) -----[2PCS]

D10. Ø3/4" SHAFT COLLAR(9211-046) -----[2PCS]

D11. 2"X4" RUBBER DOUNT(9212-009) -----[3PCS]

D12. Ø1"X10" RUBBER GRIP(9310-029) -----[2PCS]

D14. 60X50 NYLON BUSHING(9211-033) -----[2PCS]

D16. Ø2-1/2" RUBBER DOUNT(9310-014) -----[2PCS]

D17. Ø150X225 FOAM ROLLER(9161-015) -----[2PCS]

D3.

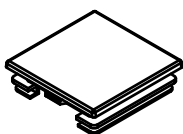

D18. CHROME TOP PLATE(8400-002) -----[1PCS]

D19. WEIGHT SELECTOR BAR(8220-060)-----[1PCS]

D20. 3750mm STEEL CABLE -----[1PCS]

D21. Ø3/4"X8L STEEL BUSHING(8110-014) -----[2PCS]

D22. Ø5/8" ROUND END CAP(9211-015)-----[4PCS]

D23. Ø5/8" SHAFT COLLAR(8130-024) -----[2PCS]

D24. Ø3" NYLON WASHER(9214-008) -----[4PCS]

D5.



D6.

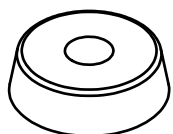

D7.

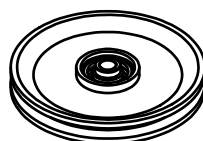

D8.

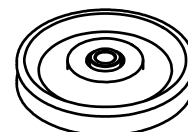

D10.

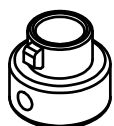

D11.

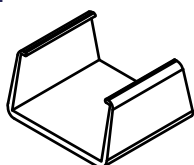

D12.

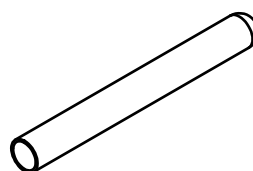

D14.

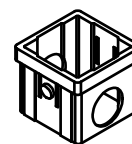

D16.



D17.

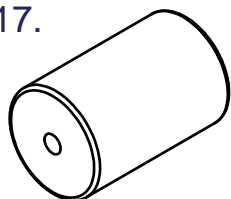

D18.

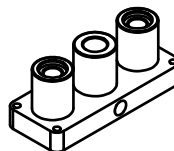

D19.

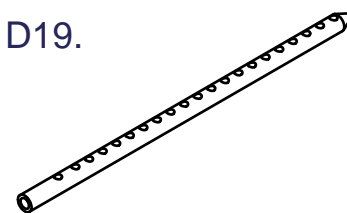

D20.

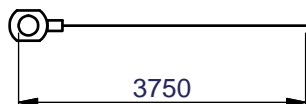

D21.



D22.



D23.



D24.



SLE-200 ASSEMBLY INSTRUCTIONS

PARTS ILLUSTRATION SHEET

A1.[1SET] WEIGHT STACK FRAME

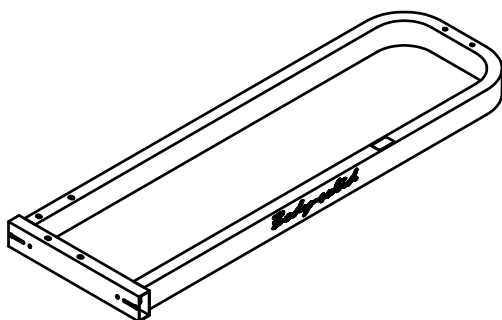

B.[1SET] BOTTOM PULLEY FRAME

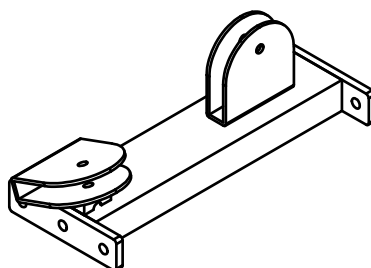

C.[1SET] MIDDLE SUPPORT FRAME

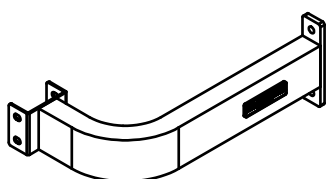

D1.[1SET] MAIN BODY FRAME

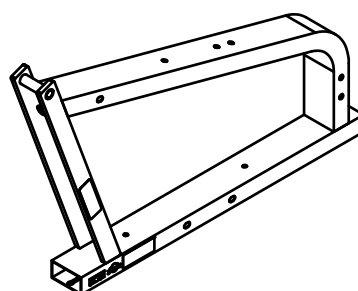

E.[1SET] LEG EXTENSION FRAME

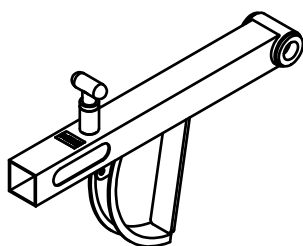

F.[1SET] ADJUSTABLE BACK SUPPORT

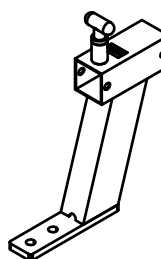

G.[1SET] BACK PAD FRAME

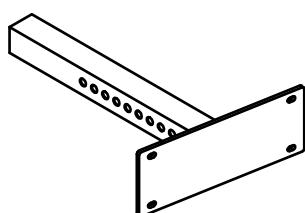

H.[1SET] TOP PULLEY FRAME

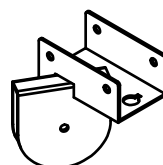

I.[1PCS] ROLLER BAR FRAME

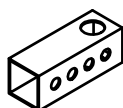

J.[1SET] ROLLER BAR FRAME

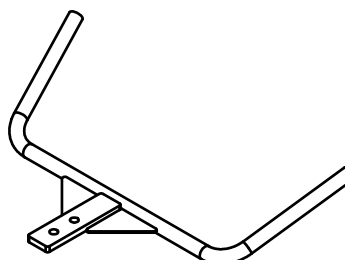

PARTS ILLUSTRATION SHEET

K.[2PCS] CHROME GUIDE ROD
(8280-002)Ø3/4"X1765L



L1.[1PCS] FOOT ROLLER BAR
(8220-058)Ø1"X610L



M.[3PCS] 2"X8" PLATE
(8312-077)

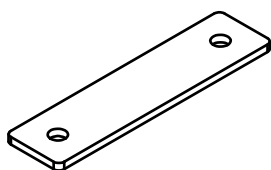

M.[2PCS] SEAT BRACKET
(8333-001)

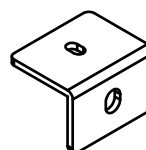

O.[1PCS] SEAT PAD
(9121-002)

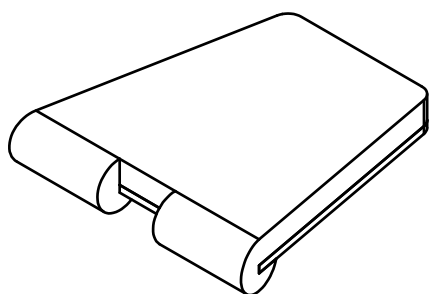

P.[1PCS] BACK PAD
(9111-014)

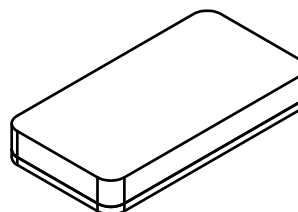

Q[1PCS]BACK PAD BUBBER
(9119-001)

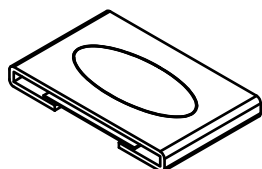

SLE-200 ASSEMBLY INSTRUCTIONS

SLE-200G LEG EXTENSION ASSEMBLY STEPS

STEP-1

NOTE: DO NOT TIGHTEN NUTS AND BOLTS SECURELY UNTIL YOU HAVE COMPLETED ALL ASSEMBLY STEPS.

- Attach A1 Weight Stack Frame and d Main Body Frame to B Bottom pulley Frame.
- Attach C Middle Support Frame to A1 Weight Stack Frame and D1 Main Body Frame.
- Attach E Leg Extension Frame to D1 Main Body Frame.
- Attach F Adjustable Back Support and J Handle Bar to D1 Main Body Frame.

STEP-2

- Attach N Seat Brackets to D1 Main Body Frame.
- Attach O Seat Pad to D1 Main Body Frame and N Seat Brackets.
- Attach P Back Pad to D1 Main Body Frame.
- Slide G Back Pad Frame into F adjustable Back support.

**CAUTION: DO NOT OVERTIGHTEN PAD BOLTS.
OVERTIGHTENING WILL STRIP
T-NUTS IN THE WOOD**

STEP-3

- Attach K Chrome Guide rods and D6 Rubber Dount to A1 Weight Stack Frame.
- Slide Weight Stack and D18 Chrome Top Plate onto K Chrome Guide rods.
- Attach H Top Pulley Frame E Leg Extension Frame.
- Slide L1 Foot Roller Bar into I Roller Bar Frame.
- Attach D17 Foam Rollers.

STEP-4

- Attach Pulleys and Cables as shown.
- Attach Edn Caps and Grips.
- TIGHTEN ALL NUTS AND BOLTS SECURELY.**
- Attach Bolt Caps.

SAFETY RULES

1. Periodically check that all nuts, bolts and screws are fully tightened on your LEG EXTENSION MACHINE.
2. Exercise with care. Perform your exercises at a smooth moderate pace; never perform jerky or uncoordinated movements that may cause injury.
3. It is recommended that you should workout with a training partner.
4. **Warning: CONSULT YOUR PHYSICIAN BEFORE STARTING YOUR EXERCISE PROGRAM. IT IS ADVISABLE TO HAVE A PHYSICAL EXAMINATION BEFORE YOU ENTER ANY EXERCISE PROGRAM. FOR YOUR OWN SAFETY, DO NOT BEGIN ANY EXERCISE WITHOUT PROPER INSTRUCTION.**

SLE-200 ASSEMBLY INSTRUCTIONS

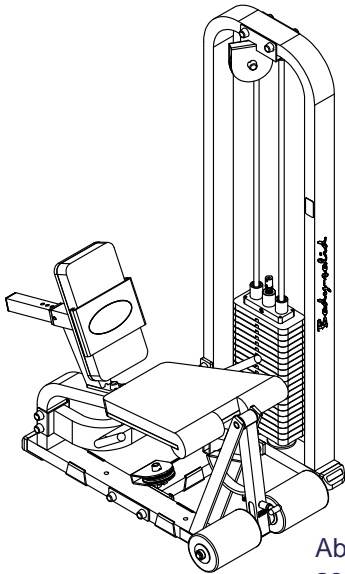

Above shows STEP2 assembled and completed

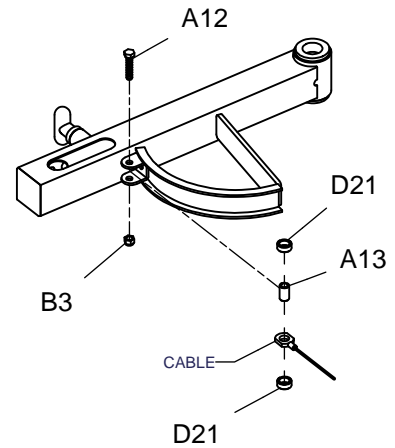

A Detail View

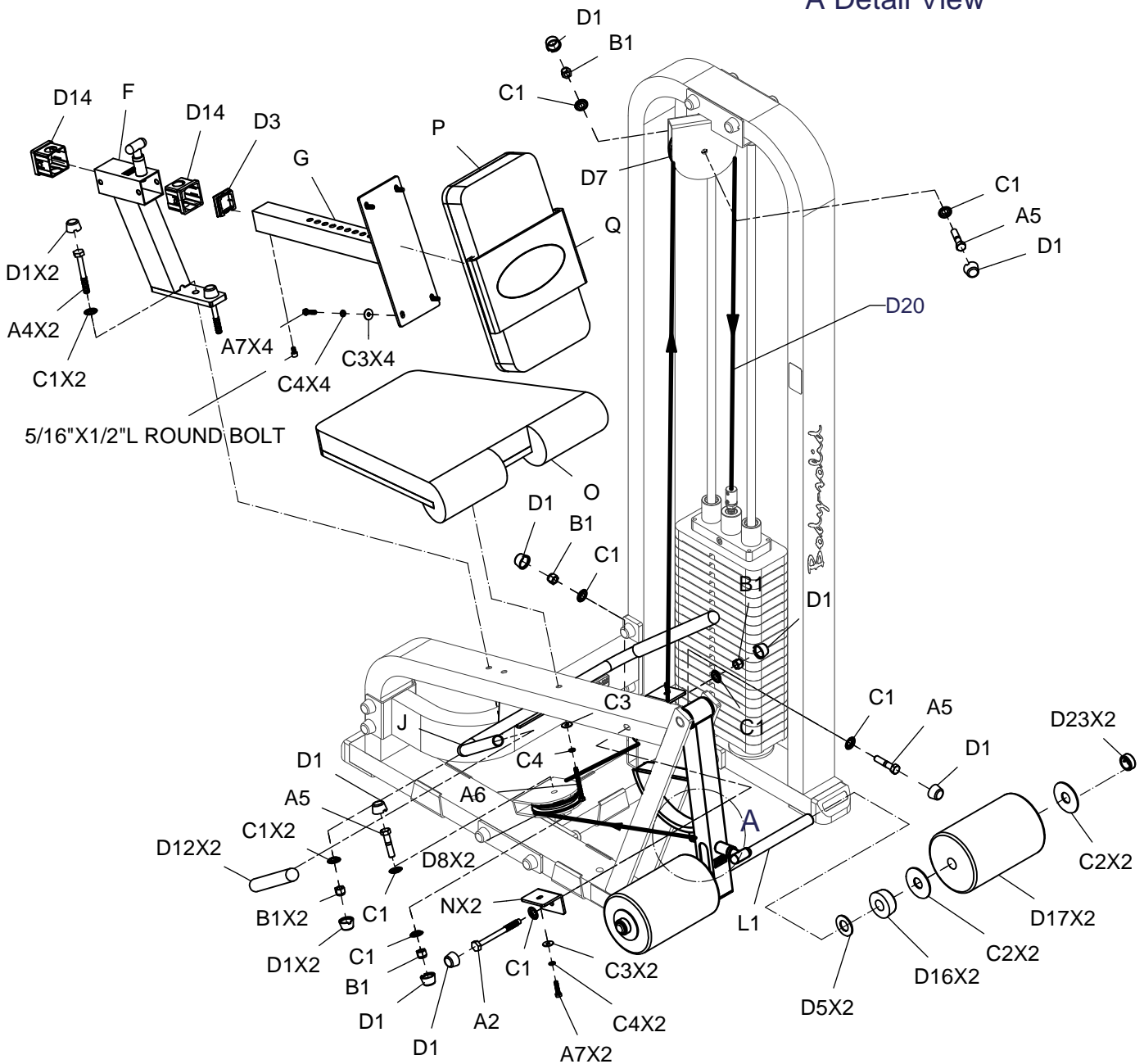

SLE-200 ASSEMBLY INSTRUCTIONS

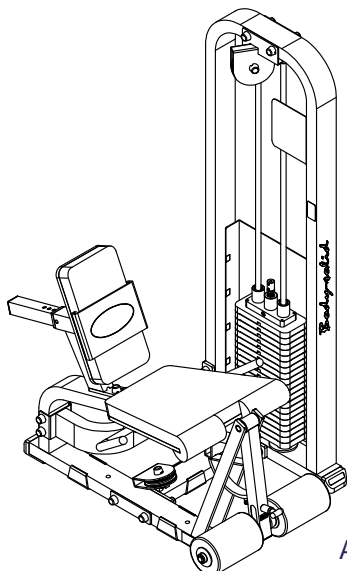

Above shows STEP3 assembled and completed

