

Body-Solid®

Built for Life

GD1B-46L

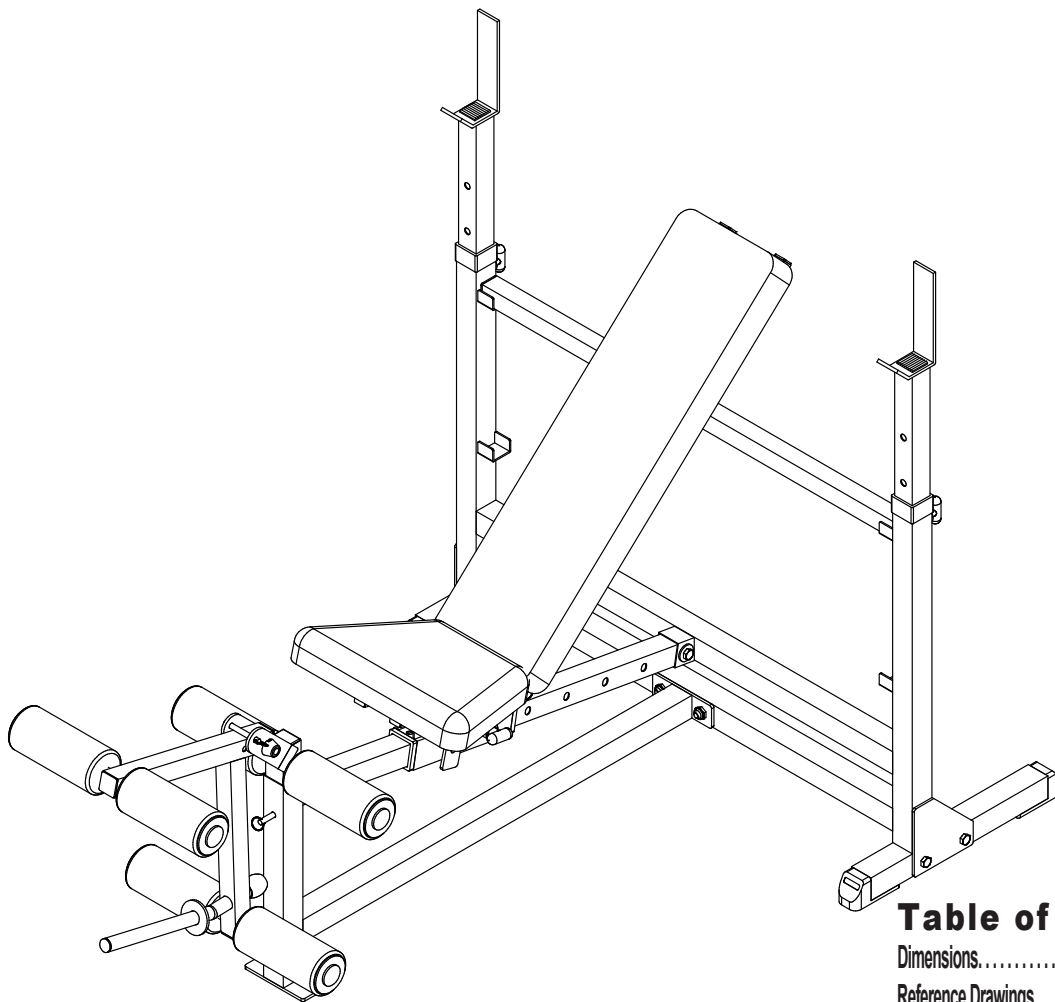

Table of Contents

| | |
|------------------------------------|----------|
| Dimensions..... | p. 2 |
| Reference Drawings..... | p. 3 |
| Important Safety Instructions..... | p. 4 |
| Before You Begin..... | p. 5 |
| Preparations..... | p. 6 |
| Assembly Instructions..... | p. 7-13 |
| Warning, Safety & Maintenance..... | p. 14-17 |
| Mainframe Parts List..... | p. 18 |
| Hardware List..... | p. 19 |
| Hardware (To Scale)..... | p. 20-21 |
| Exploded View Diagram..... | p. 22 |
| Notes..... | p. 23 |

Assembly Instructions

OWNER'S & MANUAL

Dimensions

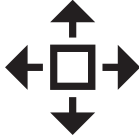

The room layout diagram below will help you decide the best placement for your GDIB-46L.

The overall space needed for operation may be more depending on the user.

Minimum Usage Space – 3' 10" W x 4' 8" L x 4' 4" H

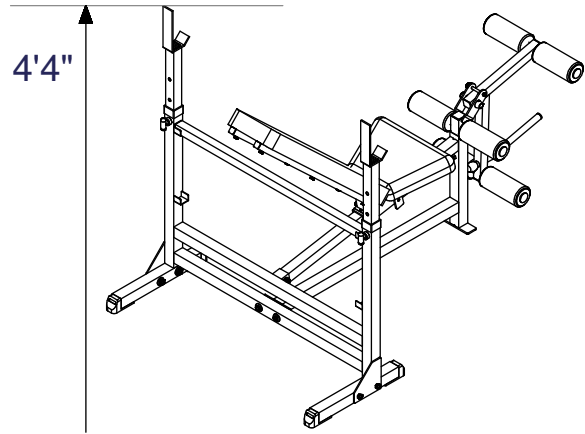
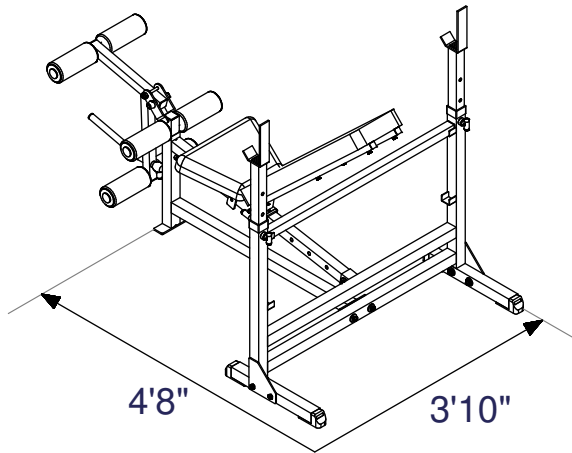

Suggested Usage Space – 6' W x 6' 8" L

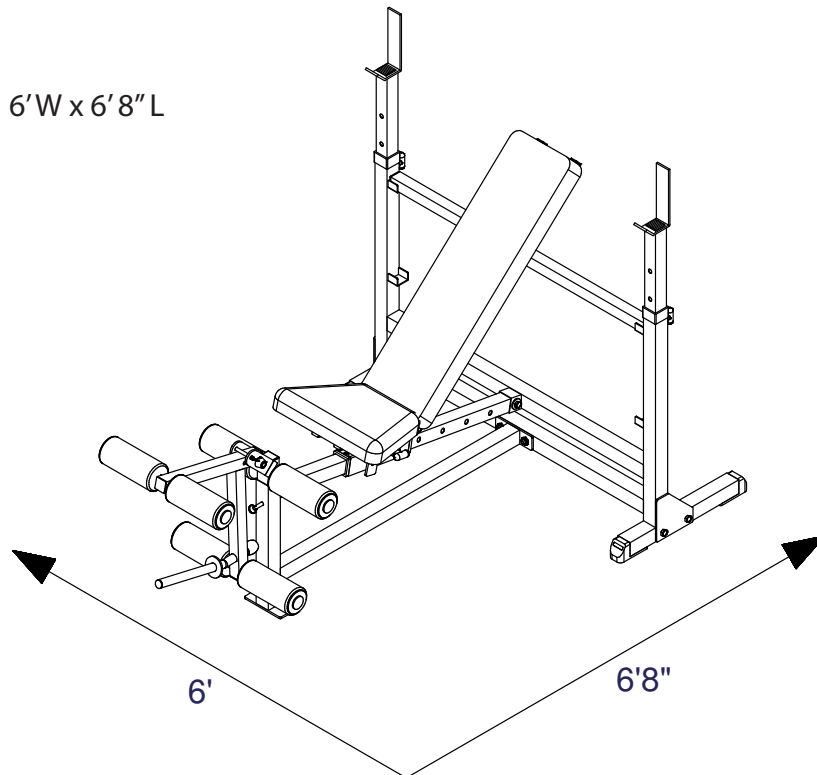

Reference Drawings



Use the following diagrams as a point of reference when assembling your GDIB-46L.

Becoming familiar with the unit and the orientation of its components will help ease installation. Please use the following diagrams to become more accustomed with your GDIB-46L and its applications.

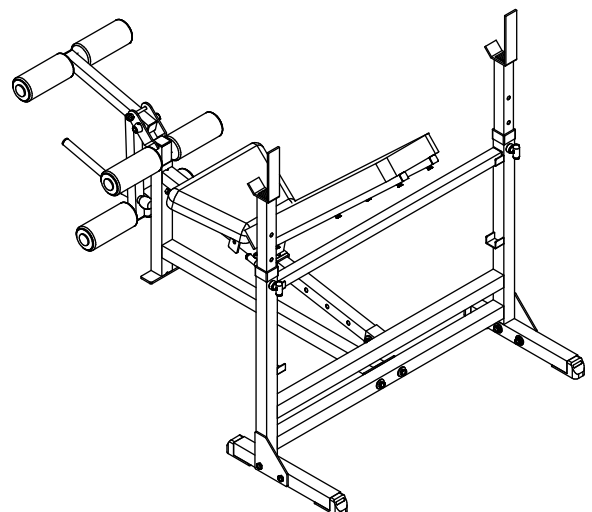
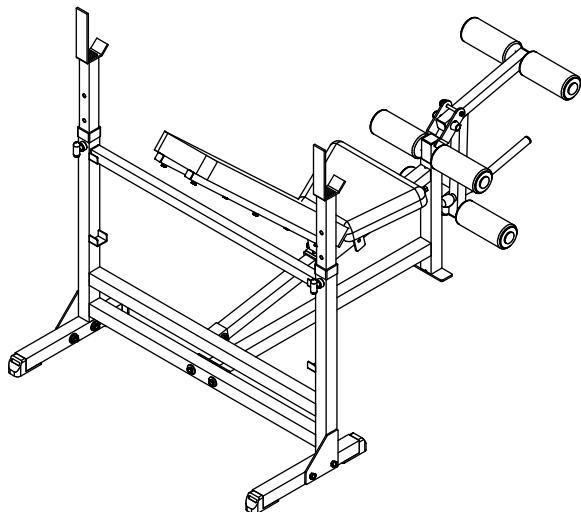
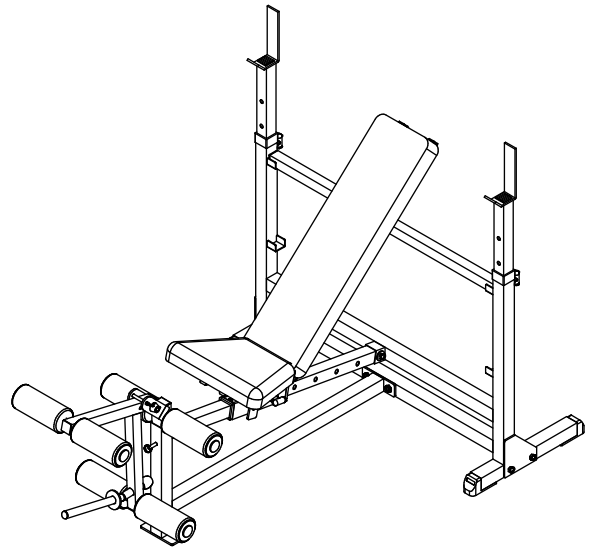
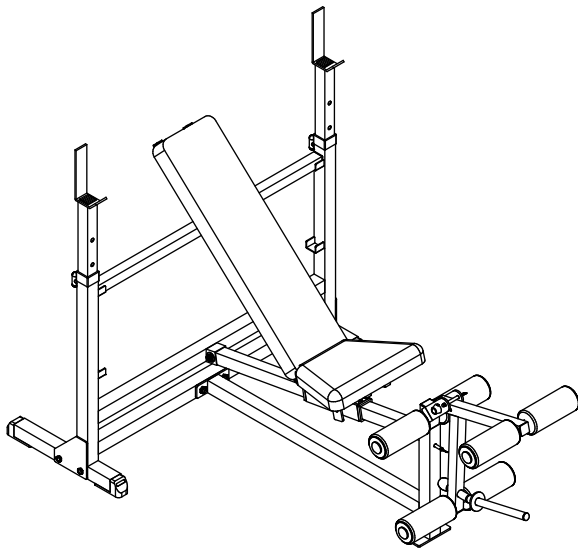

Important Safety Instructions



Before beginning any fitness program, you should obtain a complete physical examination from your physician.

Il est conseillé de subir un examen médical complet avant d'entreprendre tout programme d'exercice. Si vous avez des étourdissements ou des faiblesses, arrêtez les exercices immédiatement.

Antes de comenzar cualquier programa de ejercicios, deberías tener un examen físico con su doctor.

When using exercise equipment, you should always take basic precautions, including the following:

- Read all instructions before using the GDIB-46L. These instructions are written to ensure your safety and to protect the unit.
- Do not allow children on or near the equipment.
- Use the equipment only for its intended purpose as described in this guide. Do not use accessory attachments that are not recommended by the manufacturer. Such attachments might cause injuries.
- Wear proper exercise clothing and shoes for your workout, no loose clothing.
- Use care when getting on or off the unit.
- Do not overexert yourself or work to exhaustion.
- If you feel any pain or abnormal symptoms, stop your workout immediately and consult your physician.
- Never operate the unit when it has been dropped or damaged. Return the equipment to a service center for examination and repair.
- Never drop or insert objects into any opening in the equipment.
- Always check the unit before each use. Make sure that all fasteners are secure and in good working condition.
- Do not use the equipment outdoors or near water.

Personal Safety During Assembly

- It is strongly recommended that a qualified dealer assemble the equipment.
Assistance is required.
- Before beginning assembly, please take the time to read the instructions thoroughly.
- Read each step in the assembly instructions and follow the steps in sequence. Do not skip ahead. If you skip ahead, you may learn later that you have to disassemble components and that you may have damaged the equipment.
- Assemble and operate the GDIB-46L on a solid, level surface. Locate the unit a few feet from the walls or furniture to provide easy access.

Before You Begin



Retain this Owner's Manual for future reference!

To maximize your use of the equipment please study this Owner's Manual thoroughly. Please retain this manual for future reference or parts information.

Thank you for purchasing the GDIB-46L.

This gym is part of the Body-Solid line of quality strength training machines, which let you target specific muscle groups to achieve better muscle tone and overall body conditioning.

Unpacking the Equipment

The GDIB-46L is carefully tested and inspected before shipment. We have shipped the unit in several pieces that require assembly. Ask for assistance during the assembly process. Carefully unpack the boxes and lay the pieces on the floor near the area where you plan to use the equipment.

The GDIB-46L is designed for your enjoyment. By following these precautions and using common sense, you will have many safe and pleasurable hours of healthful exercise with your Body-Solid GDIB-46L.

After assembly, you should check all functions to ensure correct operation. If you experience problems, or if any items are missing, first recheck the assembly instructions to locate any possible errors made during assembly. If you are unable to correct the problem, call the dealer from whom you purchased the machine or call 1-800-556-3113 for the dealer nearest you.

Obtaining Service

Please use this Owner's Manual to make sure that all parts have been included in your shipment. When ordering parts, you must use the part number and description from this Owner's Manual. Use only Body-Solid replacement parts when servicing this unit. Failure to do so will void your warranty and could result in personal injury.

For information about product operation or service, check out the official Body-Solid website at www.bodysolid.com or contact an authorized Body-Solid dealer or a Body-Solid factory-authorized service company or contact Body-Solid customer service, *M-F 8:30am-5:00pm CST*, at one of the following:



Toll Free: (800) 556-3113

Local: (708) 427-3555

Fax: (708) 427-3556



E-mail: service@bodysolid.com

or write to:



**Body-Solid, Inc.
Service Department
1900 S. Des Plaines Ave.
Forest Park, IL 60130 USA**

Body-Solid continually seeks ways to improve the performance, specifications and product manuals in order to ensure that only superior products are released from our factories. Please take the time to carefully read through this manual thoroughly. Instructions contained in this document are not intended to cover all details or variations possible with Body-Solid equipment, or to cover every contingency that may be met in conjunction with installation, operation, maintenance or troubleshooting of the equipment. Even though we have prepared this manual with extreme care, neither the publisher nor the author can accept responsibility for any errors in, or omission from, the information given. Should additional information be required, or should situations arise that are not covered by this manual, the matter should be directed to your local Body-Solid representative, or the Service Department at Body-Solid Inc. in Forest Park, Illinois.

Any Questions?
Call (800) 556-3113

Preparations



CAUTION: To set up this unit, you will need assistance. Do not attempt assembly by yourself.

You must review and follow the instructions in this Owner's Manual. If you do not assemble and use the GDIB-46L according to these guidelines, you could void the Body-Solid warranty.

CAUTION !

Obtain assistance! Do not attempt to assemble the GDIB-46L by yourself. Review the Installation Requirements before proceeding with the following steps.

Required Tools

The basic tools that you must obtain before assembling the GDIB-46L include but are not limited to:

- Standard Wrench Set
- Metric Wrench Set
- Adjustable Wrench
- Allen Set
- Rubber Mallet
- Silicone Spray Oil
- Knife

Installation Requirements

Follow these installation requirements when assembling the GDIB-46L:

Set up the GDIB-46L on a solid, flat surface.

A smooth, flat surface under the machine helps keep it level. A level machine has fewer malfunctions.

Provide ample space around the machine.

Open space around the machine allows for easier access and a more comfortable workout.

Insert all bolts in the same direction.

For aesthetic purposes, insert all bolts in the same direction unless specified (in text or illustrations) to do otherwise.

Leave room for adjustments.

Tighten fasteners such as bolts, nuts, and screws so the unit is stable, but leave room for adjustments. Do not fully tighten fasteners until instructed in the assembly steps to do so.

Fill out and mail the warranty card.

To benefit from the best and most comprehensible warranty in the fitness industry, completely fill out and mail the warranty card enclosed with the unit.

Assembly Instructions



Assembly of the GDIB-46L takes professional installers about 1 hour to complete.

Professional installers are highly recommended!

If this is the first time you have assembled this type of equipment, plan on significantly more time. However, if you acquire the appropriate tools, obtain assistance, and follow the assembly steps sequentially, the process will take time, but is fairly easy.

Assembly Tips

Read all "Notes" on each page before beginning each step.

While you may be able to assemble the GDIB-46L using the illustrations only, important safety notes and other tips are included in the text.

Some pieces may have extra holes that you will not use. Use only those holes indicated in the instructions and illustrations.

IMPORTANT!

Before you begin you should look at the quick reference guide that shows all hardware parts (in actual size) along with the corresponding component numbers in the assembly instructions.

To find out the length of a particular bolt, measure its shank (the long, narrow part beneath the head) using the ruler below. Refer to the following diagram:

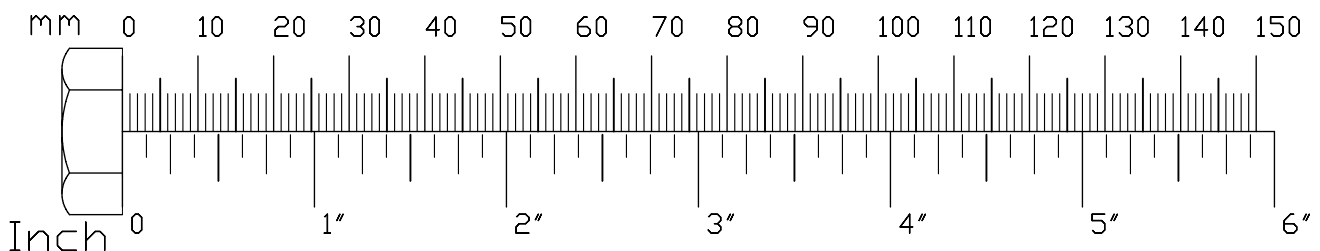
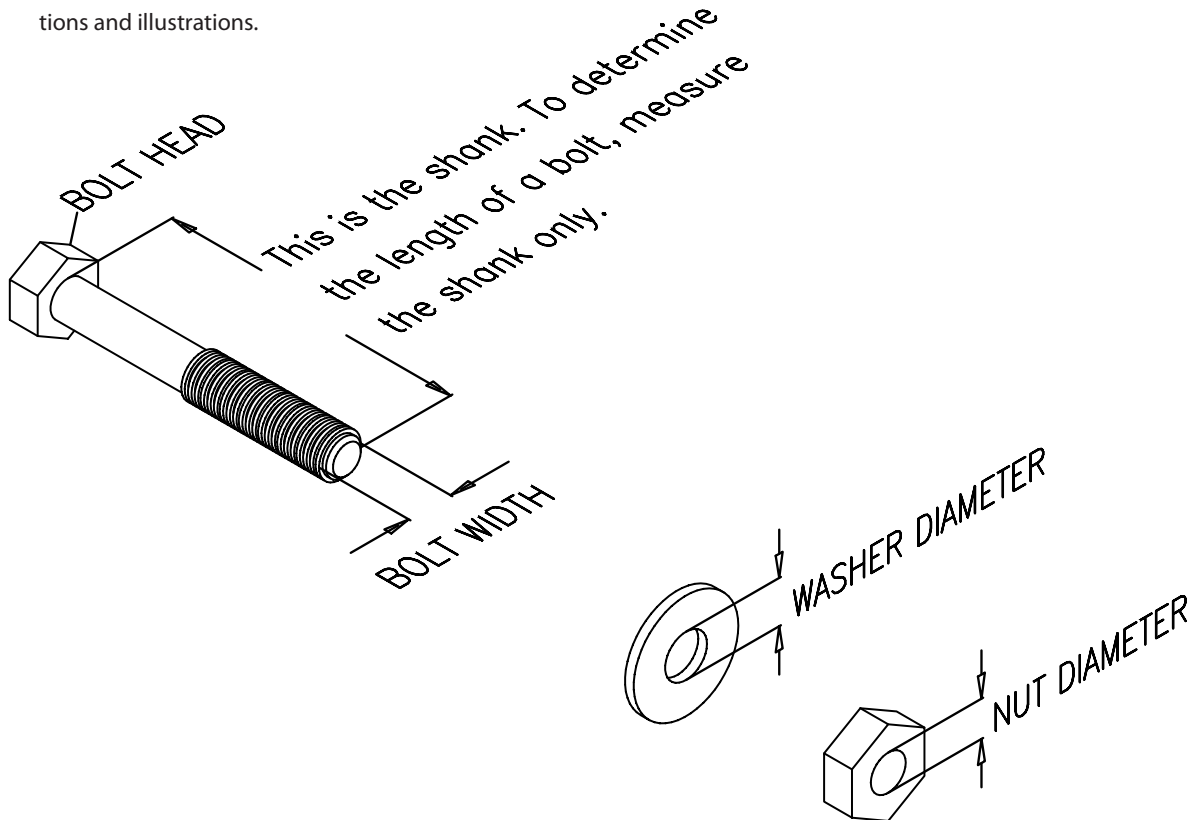

STEP

1

Be careful to assemble all components in the sequence they are presented.

**NOTE: Finger tighten all hardware in this step.
Do Not wrench tighten until the end of Step 3.**

- A. Insert both Foot Caps (14) into each Bottom Support Frame (H).
- B. Connect both Bottom Support Frame (H) to Back Cross Frame (A) using for each Bottom Support Frame (H):
 - Two 1 (M12x75 hex head bolt)**
 - Two 7 (M12 washer)**
 - Two 5 (M12 nylon lock nut)**
- C. Insert both Nylon Bushings (15) into Seat Carriage (C).
- D. Insert Seat Carriage (C) onto Middle Frame (B) by loosening Pop Pin (28) and Knob (29).
- E. Connect Middle Frame (B) to Back Cross Frame (A) using:
 - Two 1 (M12x75 hex head bolt)**
 - Four 7 (M12 washer)**
 - Three 5 (M12 nylon lock nut)**
 - One 4 (M12x70 hex head bolt)**
- F. Insert End Cap (11) into Seat Carriage (C).

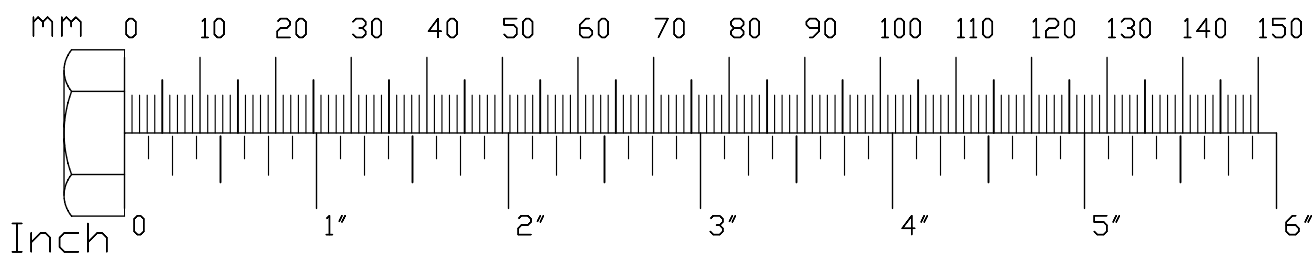

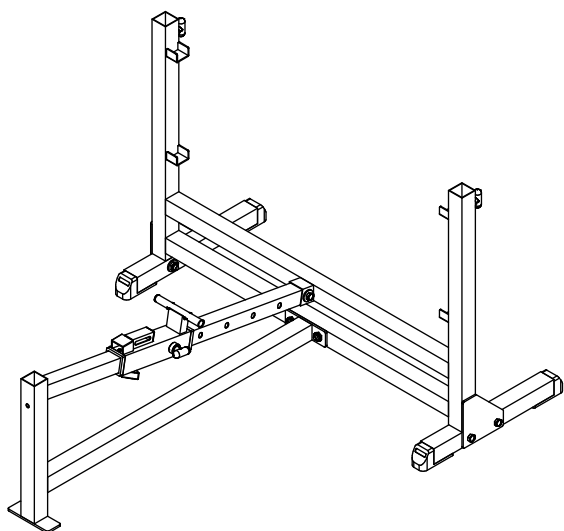

Above shows Step 1 assembled and completed.

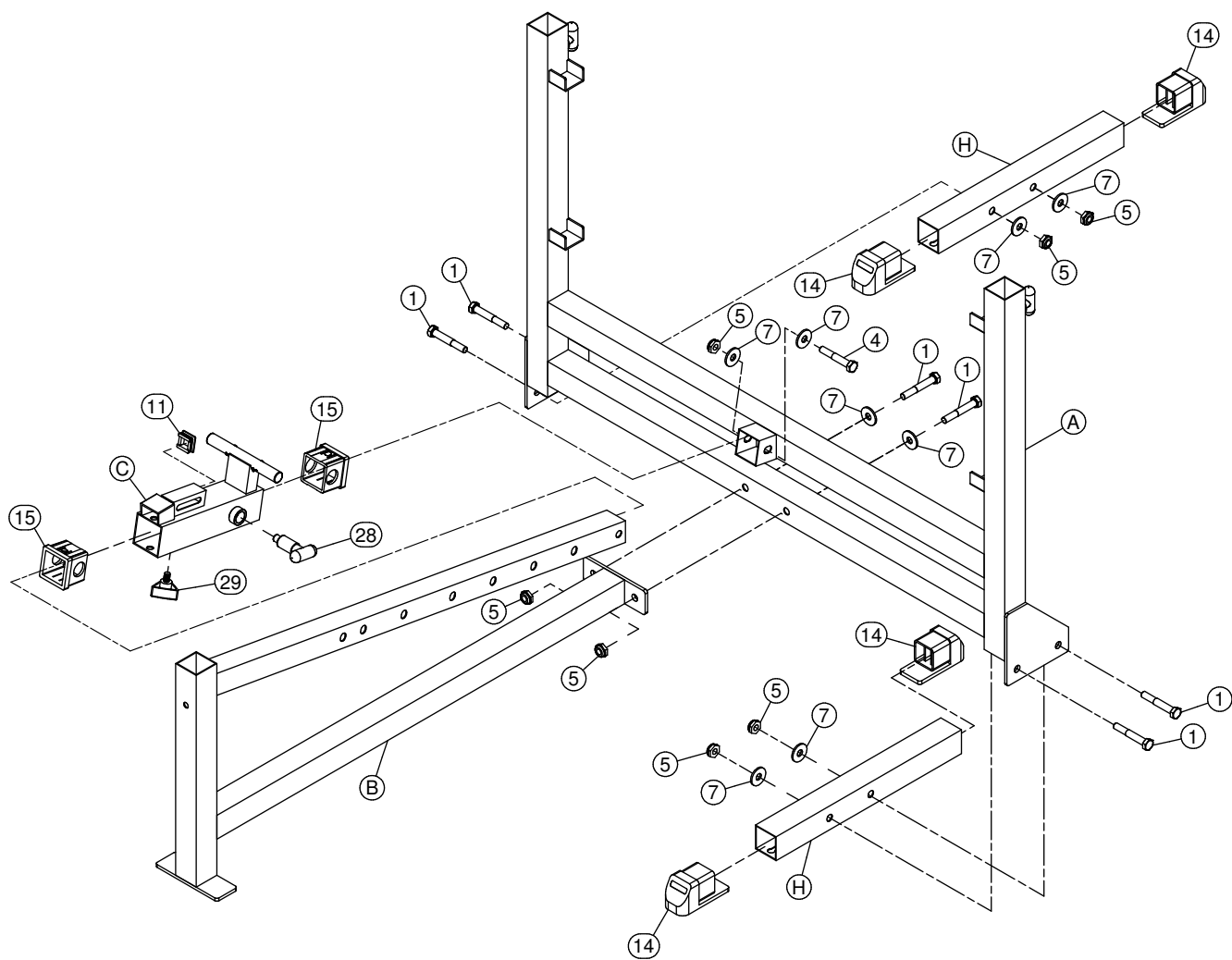

STEP**2**

Be careful to assemble all components in the sequence they are presented.

**NOTE: Finger tighten all hardware in this step.
Do Not wrench tighten until the end of Step 3.**

- A. Insert both End Caps (19) into Stabilizing Bar (G).
- B. Lay Stabilizing Bar (G) on Back Cross Frame (A) as shown.
- C. Insert a Nylon Bushing (16) onto each Back Cross Frame (A).
- D. Insert an End Cap (12) into each Back Pad Frame (E).
- E. Insert an End Cap (12) into each Seat Pad Frame (F).
- F. Attach a Rubber Bar Catch (3) onto each Lift Off (D).
- G. Insert a Lift Off (D) into each Back Cross Frame (A) by loosening Pop Pin (28).
- H. Insert Seat Pad Frame (F) onto the shaft on each side of Seat Carriage (C).
- I. Insert Back Pad Frame (E) onto the shaft on each side of Seat Carriage (C).
- J. Connect Seat Pad (L) to Seat Pad Frame (F) using:
Four 2 (M8x45 hex head bolt)
Four 9 (M8 spring washer)
Four 8 (M8 washer)

NOTE: *Do NOT over-tighten the bolts as this will cause the T - nuts in pads to strip out.
Tighten the bolts until the spring lock washer is flat.

- K. Connect Back Pad (K) to Back Pad Frame (E) using:
Six 2 (M8x45 hex head bolt)
Six 9 (M8 spring washer)
Six 8 (M8 washer)

NOTE: *Do NOT over-tighten the bolts as this will cause the T - nuts in pads to strip out.
Tighten the bolts until the spring lock washer is flat.

- L. Insert Ball Pin (17) into Seat Pad Frame (F).

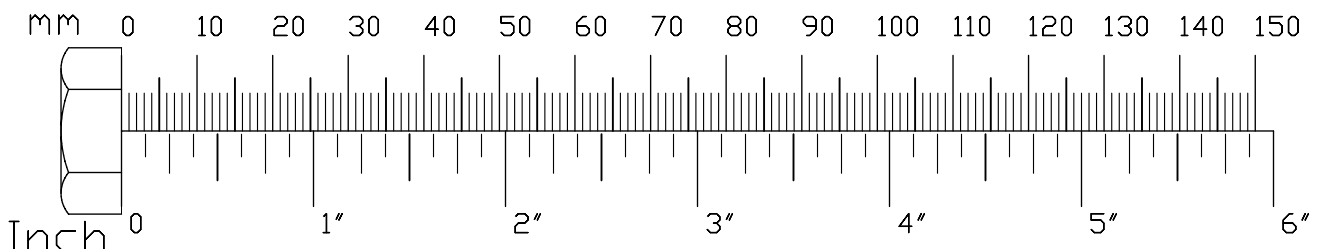

STEP
2

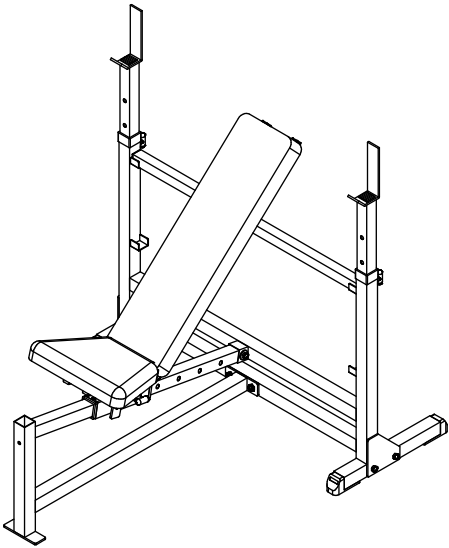

Above shows Step 2 assembled and completed.

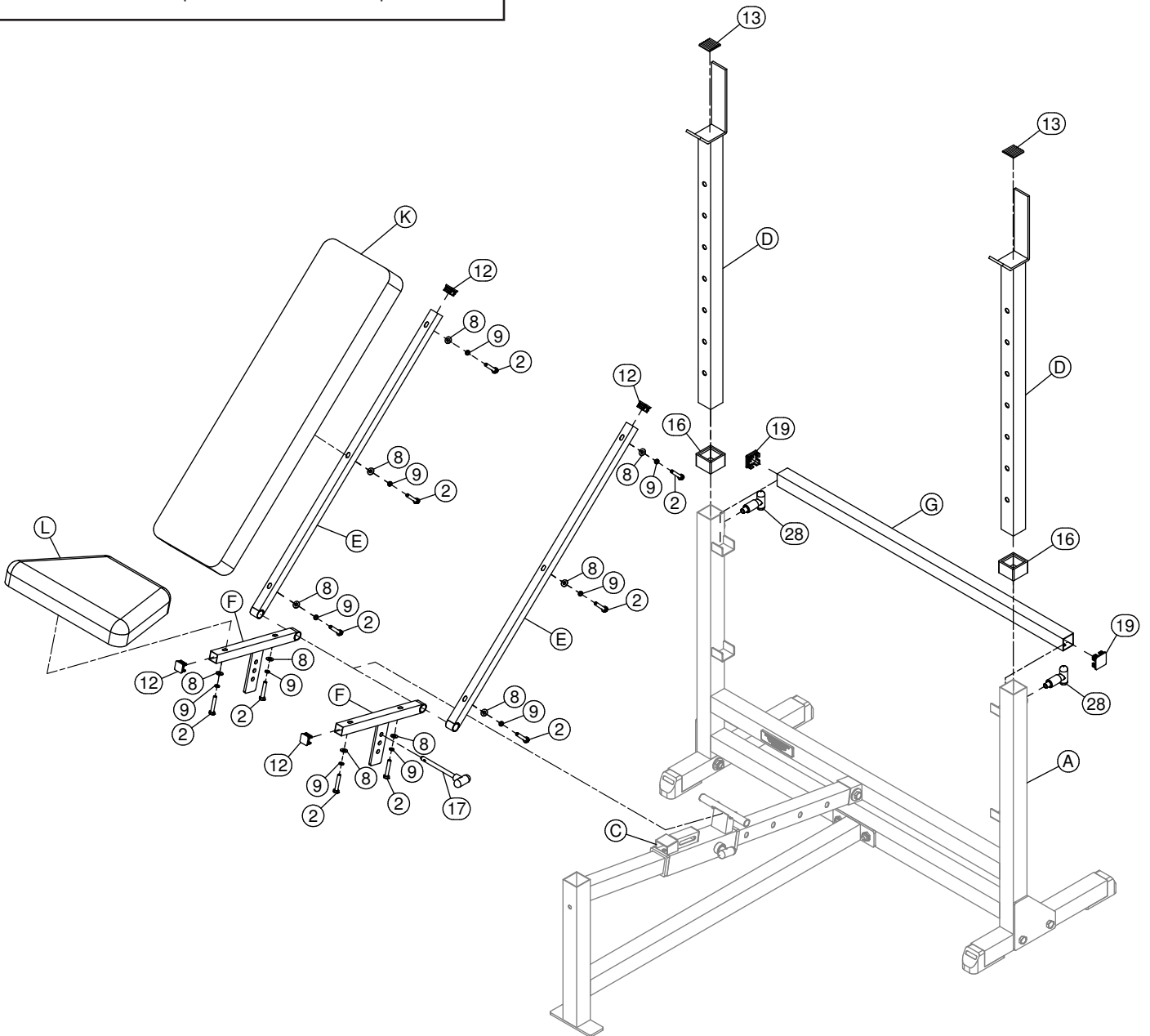

STEP**3**

Be careful to assemble all components in the sequence they are presented.

**NOTE: Finger tighten all hardware in this step.
Do Not wrench tighten until the end of Step 3.**

- A. Insert End Cap (21) into Leg Pivot Frame (I).
- B. Insert three End Caps (19) into Leg Frame (J).
- C. Insert Leg Pivot Frame (I) into Middle Frame (B) and secure using Ring Pin (18) Knob (29).
- D. Insert Long Roller Bar (N) into Leg Pivot Frame (I).
- E. Slide both Foam Rollers (24) onto each side of Long Roller Bar (N).
- F. Slide both Nylon Washers (27) onto each side of Long Roller Bar (N).
- G. Tap both Round End Caps (26) onto each end of Long Roller Bar (N).
- H. Insert Rubber Cane Tip (23) onto Leg Frame (J).
- I. Insert Round End Cap (22) onto Leg Frame (J).
- J. Slide Leg Frame (J) into Leg Pivot Frame (I) using:
One 3 (1/2" x 85 hex head bolt)
Two 10 (round cap washer)
One 6 (1/2" nylon lock nut)
Two 20 (bolt cap)
- K. Insert Ring Pin (25) into Leg Pivot Frame (I).
- L. Insert both Short Roller Bars (M) into Leg Frame (J).
- M. Insert both Foam Rollers (24) onto each Leg Frame (J).
- N. Insert both Nylon Washers (27) onto each Leg Frame (J).
- O. Tap both Round End Caps (26) onto each Leg Frame (J).
- P. Congratulations! The assembly of the GDIB-46L is complete.

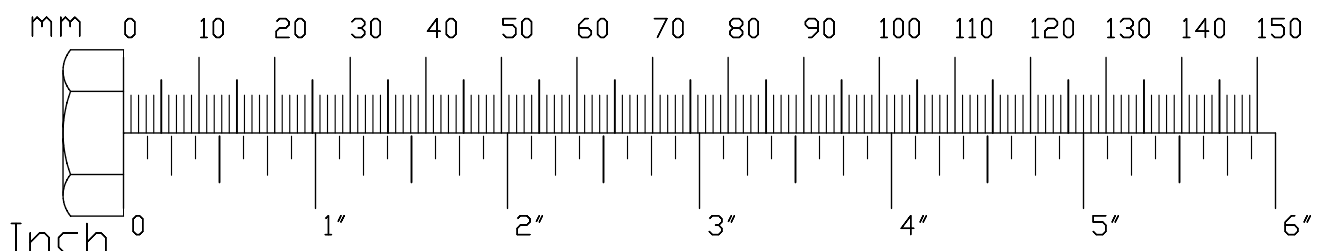

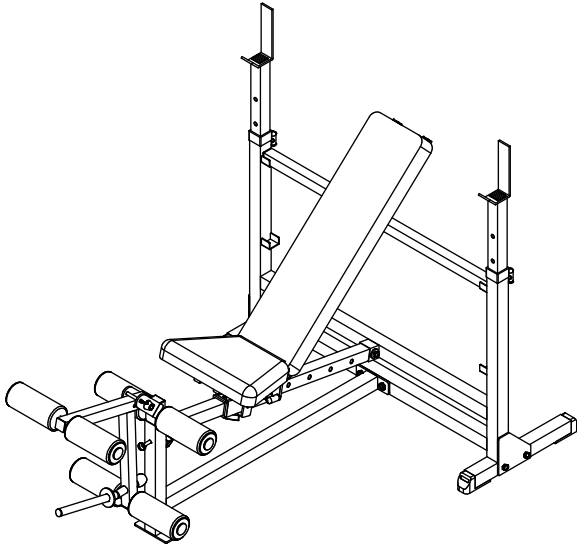

Above shows Step 3 assembled and completed.

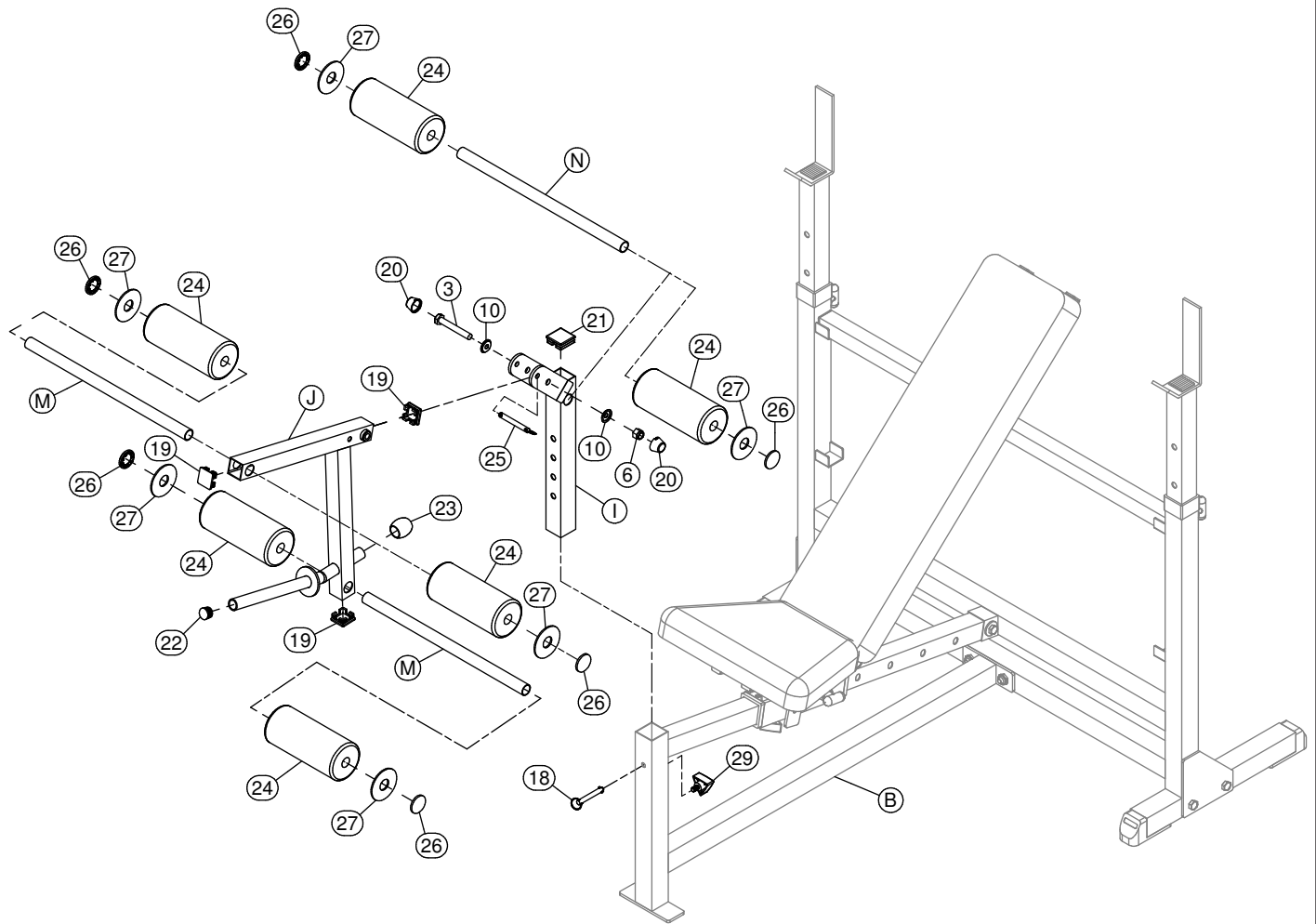

Warning, Safety & Maintenance



It is imperative that the user becomes familiar and understands all warnings posted on the unit.

To minimize the risk of injury, follow all safety guidelines provided with the unit and owner's manual.

Be sure that all users carefully read and understand all warning, safety and maintenance labels on the machine before each use. Failure to do so may result in death or serious injury.

It is imperative that you retain this Owner's Manual and be sure all warning labels are legible and intact. Replacement Owner's Manuals and warning labels are available from your local Body-Solid dealer.

If you have any questions about the operation, set up or maintenance of this machine please call our customer service department at (800) 556-3113.

| MAINTENANCE SCHEDULE | | D | A | W |
|--|---|---|---|---|
| Check the function and integrity of the following components. As noted, inspect equipment before each workout. Replace all damaged, broken or worn components immediately. | | D | A | W |
| Cables: | Check tension, end fittings, and coating | ✓ | | |
| | Check that locking nut at weight stack is tight | | | ✓ |
| Upholstery: | Wipe down and dry | ✓ | | ✓ |
| | Clean and condition | | | ✓ |
| Frame: | Wipe down and dry | ✓ | | ✓ |
| | Polish / Wax | | | ✓ |
| Chrome: | Wipe down and dry | ✓ | | ✓ |
| | Polish / Lubricate | | | ✓ |
| Nuts / Bolts / Fasteners: | Tighten and / or adjust as needed | | | ✓ |
| Guide Rods: | Lubricate and clean | | | ✓ |
| Linear Rods: | Lubricate and clean | | | ✓ |
| Seat Sleeves: | Lubricate and clean | | | ✓ |
| Adjustments / Locking Pins / Tightening Knobs | | | | ✓ |
| Weight Stack Pins | | | | ✓ |
| Warning Instruction Labels | | | | ✓ |
| Springs / Pop Pins | | ✓ | | |
| Anti Skid Surfaces | | | | ✓ |
| Hand Grips / Rollers | | | | ✓ |

For Body-Solid Customer Service
Call 1-800-556-3113
#MSSTKR0803

Warning Label for Maintenance

THERE IS A RISK ASSUMED BY INDIVIDUALS WHO USE THIS TYPE OF EQUIPMENT. TO MINIMIZE RISK, YOU MUST FOLLOW THESE RULES:

1. Inspect equipment before each workout. Check that all nuts, bolts, screws and pop pins are in place and fully tightened. Also, before use, check cables for signs of wear. Replace all worn parts immediately. Never use machine if any parts are damaged or missing. **FAILURE TO FOLLOW THESE RULES MAY RESULT IN SERIOUS INJURY.**
2. Keep clear of the cables and all moving parts when the machine is in use.
3. Always make sure all Snap Links are closed when doing any cable/pulley/strap exercises.
4. Exercise with care. Perform your exercises at a smooth moderate pace; never perform jerky or uncoordinated movements that may cause injury.
5. It is recommended that you should workout with a training partner.
6. Do not allow children or minors to play on or around this equipment.
7. If unsure of proper use of equipment, call your local Body-Solid distributor or the Body-Solid customer service department at 1-800-556-3113.
8. **WARNING:** Consult your physician before starting your exercise program. For your own safety, do not begin any exercise program without proper instruction. RAL8-6-03 WC-54

Warning Label for Rules

Warning, Safety & Maintenance



Serious injuries can be avoided with a thorough, careful and daily inspection of your equipment.

Discontinue use and replace any worn parts immediately to avoid exposure to dangerous conditions.



WARNING

To avoid serious injury, Weight Horn Collars must be used to lock the weight plates onto the weight posts. Failure to use Weight Horn Collars properly may result in death or serious injury.

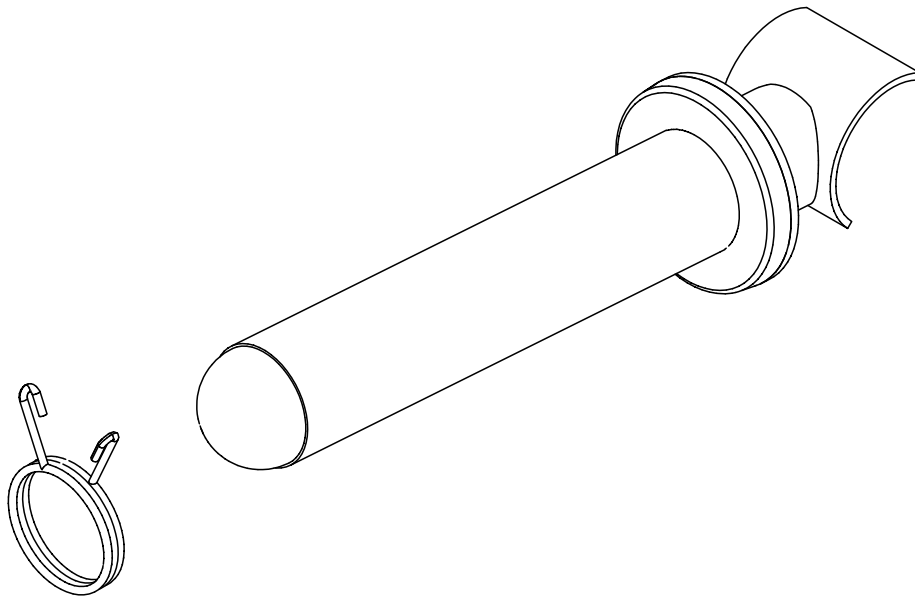

For more information or to purchase a Weight Horn Collar visit www.bodysolid.com



It is imperative that the user becomes familiar and understands all warnings posted on the unit.

To minimize the risk of injury, follow all safety guidelines provided with the unit and owner's manual.

Precision craftsmanship assures Body-Solid's ability to consistently deliver products of the highest standards. Our products have been carefully designed to ensure safe, efficient long term operation.

However, it must be realized that safe use of this equipment requires that owners carefully read and follow the Body-Solid use recommendations, warnings, and maintenance guidelines in this Owners Manual.

Routine inspection and maintenance is of critical importance to ensure maximum safety and performance. Body-Solid uses the highest quality materials available, but wear is inevitable. Therefore, you must carefully inspect your equipment as outlined in the Maintenance Schedule.

Be advised that dangerous conditions can arise even during a warranty period. A warranty does not negate the owner's responsibility to thoroughly, carefully and daily inspect the machine.

Including maintaining the equipment, the owner's responsibility is also to:

- Be sure to always provide adequate supervision to all end-users.
- Be sure to instruct all end-users of proper usage.
- Be sure all supervisors and personal trainers who instruct end-users on equipment use are properly trained and know the function and importance of every adjustment and setting.
Also, be sure these trainers provide proper instruction to end-users on the fundamentals of strength training.

CABLES:

- While the machine is not in use, carefully run your fingers along the cable to feel for thinning or bulging areas. Replace cables immediately at the first sign of damage or wear. Do not use the equipment until the damaged cable has been replaced.
- Visually inspect the cables for fraying, cracking, peeling or discoloration.
- Check slack in cables and re-adjust cable tension if needed.
- Check that the jam nut on the selector rod top bolt is tight.

UPHOLSTERY:

- Wipe down and sanitize after every workout.
- Periodically take the time to use a mild soap or a mild vinyl upholstery cleaner. Avoid using any abrasive cleaner not intended for use on vinyl.
- Keep sharp or pointed objects out of your pockets and clear of all upholstery.

NUTS/BOLTS/FASTENERS:

- Periodically inspect all nuts and bolts. Tighten if needed. If bolts seem to loosen periodically, use Loctite 242 for a long-term cure.
- Go through a re-tightening sequence periodically to ensure that all hardware is properly tensioned.

GUIDE RODS:

- Wipe clean with a dust free rag. Lubricate with a Silicon or Teflon based lubricant.

ADJUSTMENTS / LOCKING PINS / TIGHTENING KNOBS:

- Check all pieces for signs of visible wear or damage.
- Check springs in Snap Links and Pop Pins for proper tension and alignment.
- If the spring sticks or has lost its rigidity, replace it immediately.

ANTI-SKID SURFACES:

- Replace if they appear worn or become slippery.

WARNING INSTRUCTION LABELS:

- Inspect and familiarize yourself with all safety warnings and other user information on decals.

Warning, Safety & Maintenance

| MAINTENANCE SCHEDULE | DAILY | WEEKLY | LATEST DATE ENTRY | | | | | | |
|--|--------------|---------------|--------------------------|---|---|---|---|---|---|
| CABLES: 1. CHECK TENSION, END FITTINGS AND COATING. 2. CHECK THAT JAM NUT ON THE SELECTOR ROD TOP BOLT IS TIGHT | ✓ | ✓ | / | / | / | / | / | / | / |
| UPHOLSTERY: 1. WIPE DOWN AND DRY. 2. CLEAN AND CONDITION. | ✓ | ✓ | / | / | / | / | / | / | / |
| FRAME: 1. WIPE DOWN AND DRY. 2. POLISH AND WAX. | ✓ | ✓ | / | / | / | / | / | / | / |
| CHROME: 1. WIPE DOWN AND DRY. 2. POLISH AND LUBRICATE. | ✓ | ✓ | / | / | / | / | / | / | / |
| NUTS/BOLTS/FASTENERS: 1. TIGHTEN AND/OR ADJUST AS NEEDED. | | ✓ | / | / | / | / | / | / | / |
| GUIDE RODS: 1. LUBRICATE AND CLEAN. | | ✓ | / | / | / | / | / | / | / |
| LINEAR RODS: 1. LUBRICATE AND CLEAN. | | ✓ | / | / | / | / | / | / | / |
| SEAT SLEEVES: 1. LUBRICATE AND CLEAN. | | ✓ | / | / | / | / | / | / | / |
| ADJUSTMENTS/LOCKING PINS/ TIGHTENING KNOBS: 1. ADJUST AND TIGHTEN AS NEEDED. | | ✓ | / | / | / | / | / | / | / |
| WEIGHT STACK PINS: 1. CHECK INTEGRITY OF PIN. | | ✓ | / | / | / | / | / | / | / |
| WARNING LABELS: 1. CHECK INTEGRITY. 2. IF TORN, DISCONTINUE OPERATION AND REPLACE WARNING LABEL. | | ✓ | / | / | / | / | / | / | / |
| SPRINGS AND POP PINS: 1. ADJUST AND TIGHTEN AS NEEDED. 2. REPLACE WORN SPRINGS. | ✓ | | / | / | / | / | / | / | / |
| ANTI-SKID SURFACES: 1. CHECK INTEGRITY. 2. REPLACE IF PEELING OR DAMAGED. | | ✓ | / | / | / | / | / | / | / |
| HAND GRIPS/ROLLERS: 1. CHECK INTEGRITY. 2. REPLACE IF WORN OR DAMAGED. | | ✓ | / | / | / | / | / | / | / |



FOR BODY-SOLID CUSTOMER SERVICE:
1-800-556-3113

Make several copies of this page to keep track of your maintenance.
 You can print more copies of this page by going to:
<http://www.bodysolid.com/support/docs.html>

Mainframe Parts List

| Part# | Qty | Description | |
|-------|-----|----------------------|--------------------|
| A | 1 | BACK CROSS FRAME | |
| B | 1 | MIDDLE FRAME | |
| C | 1 | SEAT CARRIAGE | |
| D | 2 | LIFT OFF | |
| E | 2 | BACK PAD FRAME | |
| F | 2 | SEAT PAD FRAME | |
| G | 1 | STABILIZING BAR | 38 x 1.8T x 1048L |
| H | 2 | BOTTOM SUPPORT FRAME | 50 x 1.8T x 450L |
| I | 1 | LEG PIVOT FRAME | |
| J | 1 | LEFT FRAME | |
| K | 1 | BACK PAD | |
| L | 1 | SEAT PAD | |
| M | 2 | SHORT ROLLER BAR | φ 1" x 1.6T x 483L |
| N | 1 | LONG ROLLER BAR | φ 1" x 1.6T x 493L |

Part numbers are required when ordering parts.

Hardware List

| Part# | Qty | Description | | |
|-------|-----|-------------------------|-------------------------|------------|
| 1 | 6 | HEX HEAD BOLT | M12x75 | |
| 2 | 10 | HEX HEAD BOLT | M8x45 | |
| 3 | 1 | HEX HEAD BOLT | ½" x 85 | |
| 4 | 1 | HEX HEAD BOLT | M12x70 | |
| 5 | 7 | NYLON LOCK NUT | M12 | |
| 6 | 1 | NYLON LOCK NUT | ½" | |
| 7 | 8 | WASHER | M12x34 | |
| 8 | 10 | WASHER | M8x18 | |
| 9 | 10 | SPRING WASHER | M8 | |
| 10 | 2 | ROUND CAP WASHER | M12 | |
| 11 | 1 | END CAP | 30x30 | (9211-002) |
| 12 | 4 | END CAP | 1" x 1" | (9211-001) |
| 13 | 2 | RUBBER BAR CATCH | 38x38 | (9310-001) |
| 14 | 4 | FOOT CAP | 2" x 2" | (9211-024) |
| 15 | 2 | NYLON BUSHING | 60x45 | (9211-032) |
| 16 | 2 | NYLON BUSHING | 50x45 | (9211-030) |
| 17 | 1 | BALL PIN | φ 10x120L | (8250-017) |
| 18 | 1 | RING PIN | φ 10x65L | (8250-015) |
| 19 | 5 | END CAP | 1 ½" x 1 ½" | (9211-003) |
| 20 | 2 | BOLT CAP | M12 | |
| 21 | 1 | END CAP | 45x45 | (9211-004) |
| 22 | 1 | ROUND END CAP | φ 1" | (9211-016) |
| 23 | 1 | RUBBER CANE TIP | φ 1" | (9212-019) |
| 24 | 6 | FOAM ROLLER | φ 3 ½" x 8" | (9161-055) |
| 25 | 1 | RING PIN | φ 10x75L | (8250-034) |
| 26 | 6 | ROUND END CAP | φ 1" | (8341-033) |
| 27 | 6 | NYLON WASHER | φ 3" | (9214-008) |
| 28 | 3 | POP PIN | | (8250-012) |
| 29 | 2 | KNOB | | (9215-004) |
| 30 | 2 | COPPER BUSHING | φ21 OD x 12.85 ID x 10L | (8520-001) |
| 31 | 1 | BODYSOLID LOGO | | (9440-027) |
| 32 | 3 | POP PIN STICKER | | (9440-104) |
| 33 | 1 | BODYSOLID PLASTIC PLATE | | (9440-199) |
| 34 | 1 | WARNING STICKER | | (9440-217) |
| 35 | 1 | WARNING STICKER | | (9440-105) |
| 36 | 1 | MAINTENANCE LABEL | | (9440-103) |

Part numbers are required when ordering parts.

Hardware (To Scale)

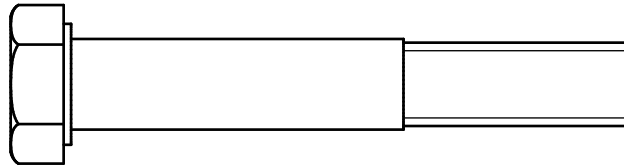

Part# 1

M12x75

Hex Head Bolt

Qty. 6

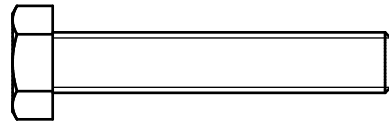

Part# 2

M8x45

Hex Head Bolt

Qty. 10

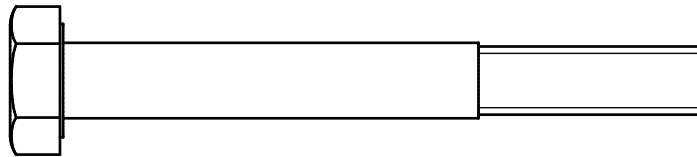

Part# 3

1/2" x 85

Hex Head Bolt

Qty. 1

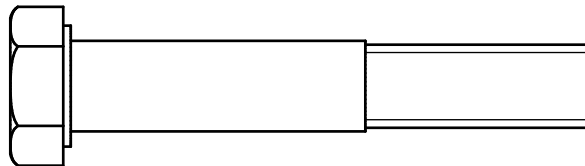

Part# 4

M12x70

Hex Head Bolt

Qty. 1

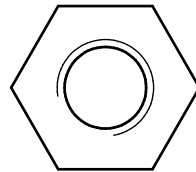
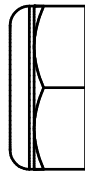

Part# 5

M12

Nylon Lock Nut

Qty. 7

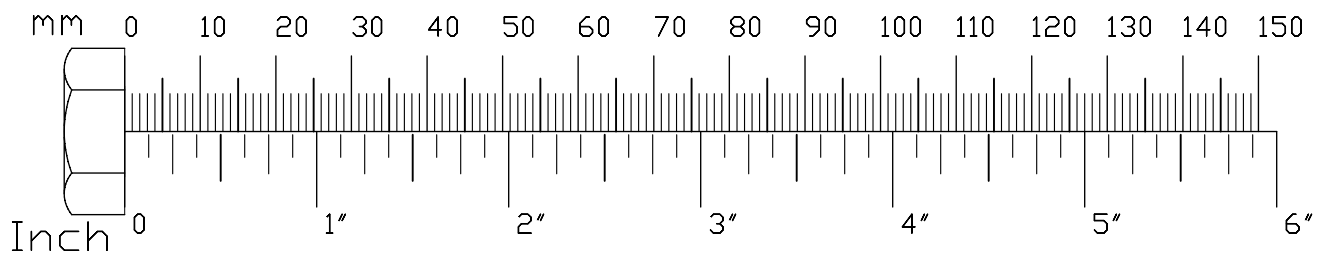

Hardware (To Scale)

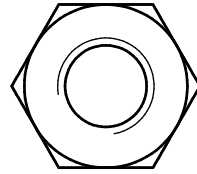

Part# 6

1/2"

Hex Head Bolt

Qty. 1

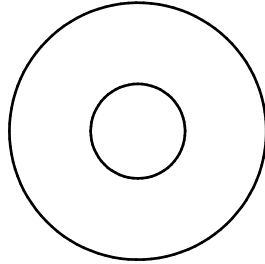

Part# 7

M12

Washer

Qty. 8

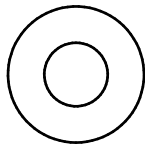

Part# 8

M18

Washer

Qty. 10

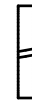
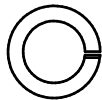

Part# 9

M8

Spring Washer

Qty. 10

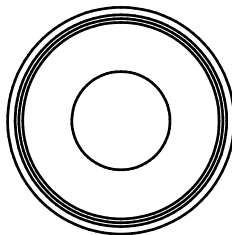

Part# 10

M12

Round Cap Washer

Qty. 2

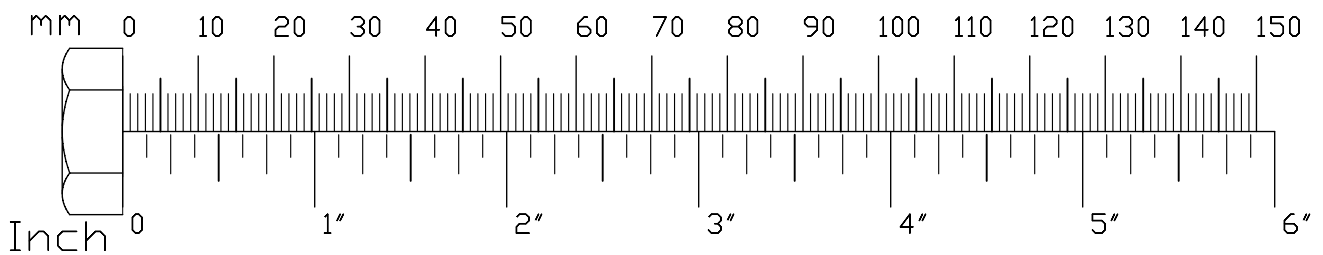

Exploded View Diagram

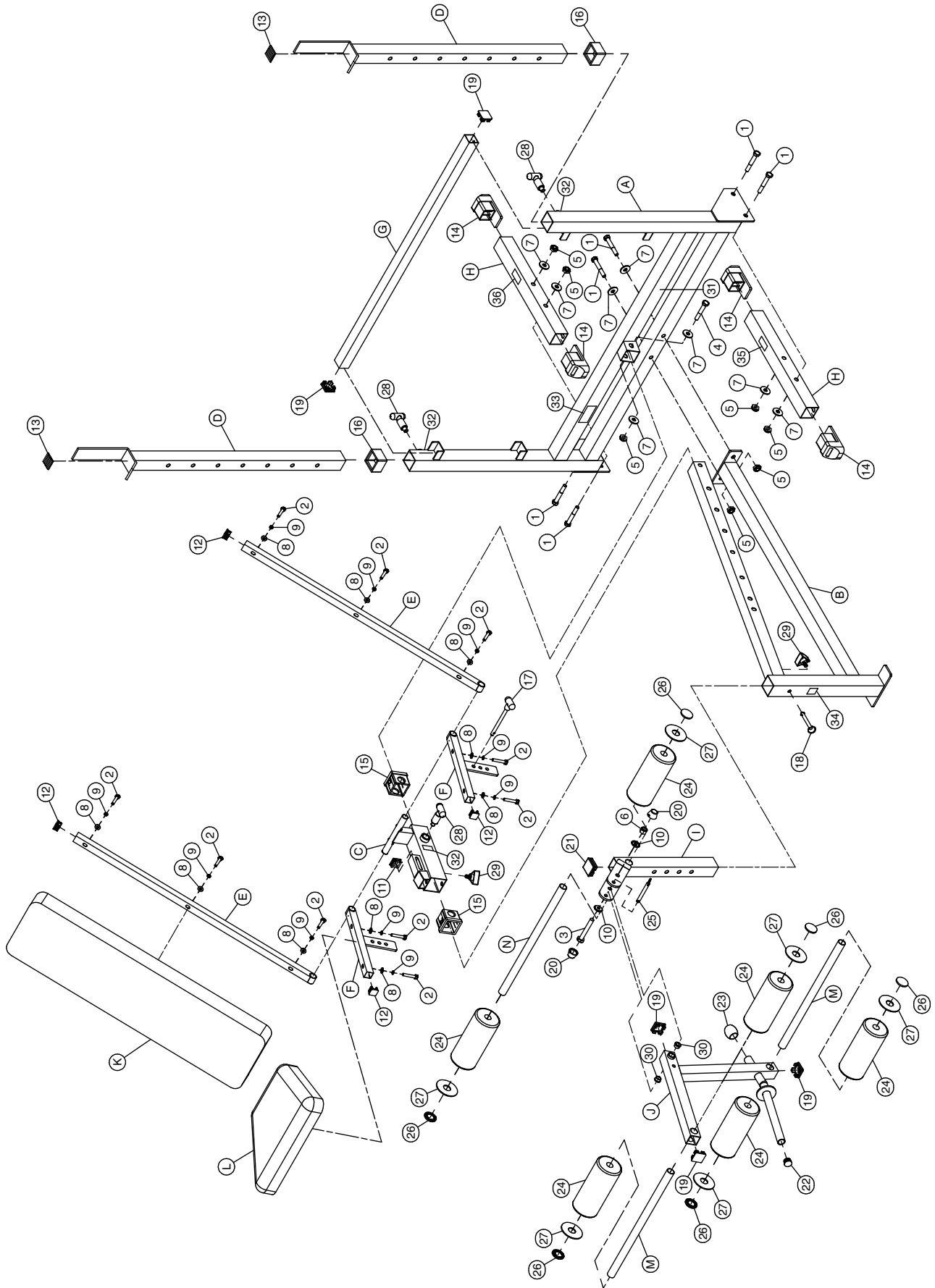

Notes

Body-Solid[®]
Built for Life

1900 S. Des Plaines Ave.
Forest Park, IL 60130
(800) 556-3113
Hours: M-F 8:30 - 5:00

www.bodysolid.com